

AFH ATC Die C0884 (V 40)

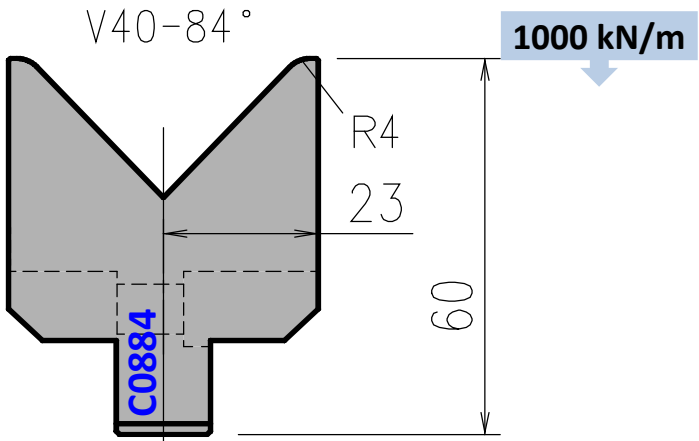

Tool angle	Length mm	Item No.	Weight Kg
84°	200 Div.	C0884405	11,2
	Short Div.	C0884406	7,1

(Short division for V40 dies = 2x20; 2x25; 2x30; 2x40; 2x50; 2x100 = 530mm)