

Closing tool

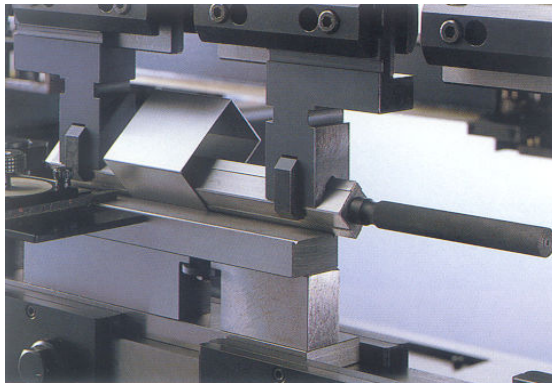
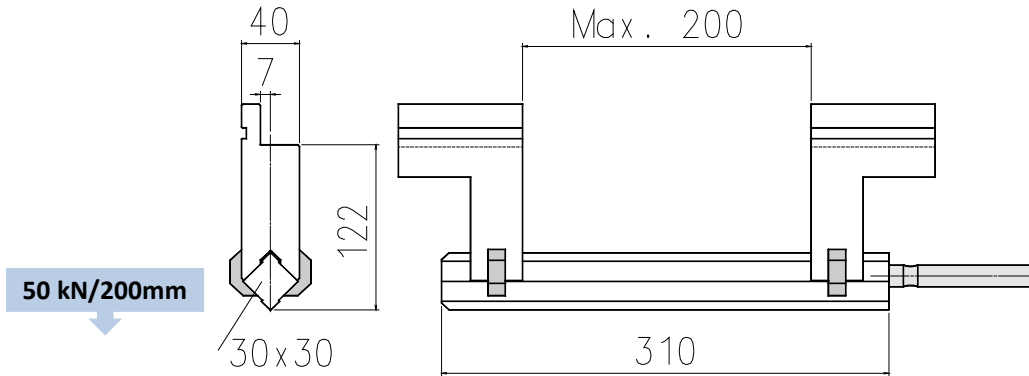

Guidance for thickness and V opening by tool gap:

Tool gap	Mild steel	Stainless steel	Aluminum
100mm	t ≤ 4,5 ≥ V40	t ≤ 2,5 ≥ V25	t ≤ 5,0 ≥ V32
150mm	t ≤ 2,3 > V16	t ≤ 1,5 ≥ V12	t ≤ 3,0 ≥ V18
200mm	t ≤ 1,6 > V10	t ≤ 0,8 ≥ V6	t ≤ 2,0 ≥ V10

Tool angle	Radius mm	Item No.	Weight Kg
88°	R0,6	C00010	6,0

Note:

- Please minimize tool gap, according to sheet part