

AFH Std. Punch 904

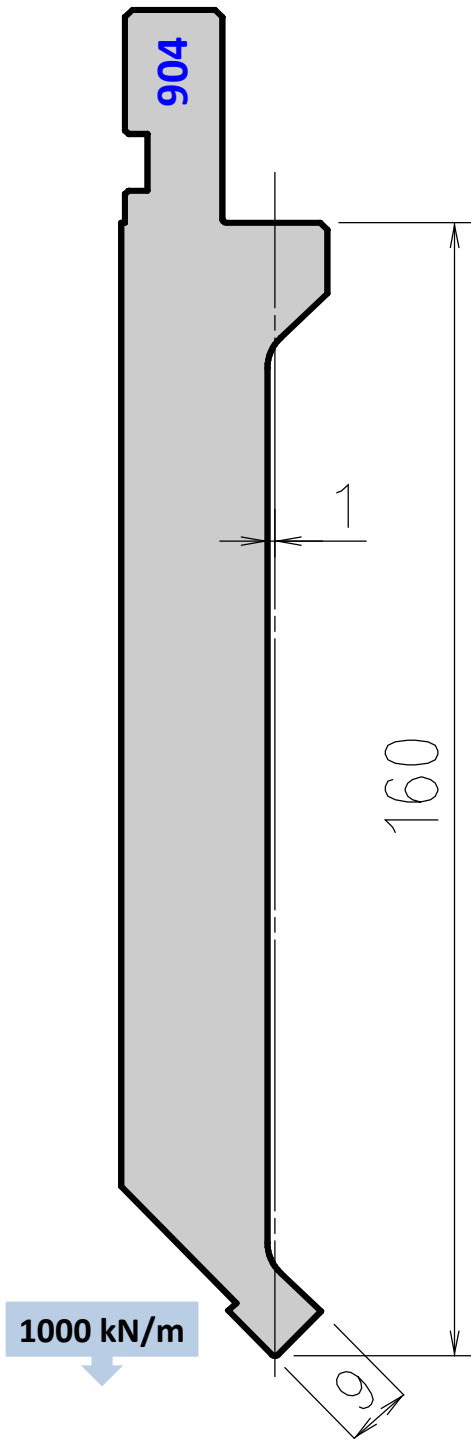

Tool angle	Tip radius	Length mm	Item No.	Wt. Kg
86°	R0.6	835	ES9048061	22,1
		415	ES9048062	11,0
		800 Sect.	ES9048063	19,5
	R1.5	835	ES9048151	22,1
		415	ES9048152	11,0
		800 Sect.	ES9048153	19,5
	R3	835	ES9048301	22,1
		415	ES9048302	11,0
		800 Sect.	ES9048303	19,5
88°	R0.6	835	ES9047061	22,1
		415	ES9047062	11,0
		800 Sect.	ES9047063	19,5

