

PRESS BRAKE TOOLING

AFH STANDARD

AFH ATC



CLICK ON YOUR PAGE LINK

- AMADA Quality ----- 3
- AFH - new tooling range ----- 4-6
- Length of tool sets ----- 7

PUNCHES

- Punches H120 86° ; 88° ; 90° ----- 8-10
- Punches H120 60° ----- 11
- Punches H120 26°; 30° ----- 12
- Large R and flattening punches----- 13
- Punches H90 ----- 14-17
- Punches H160 ----- 18-19
- Punches H70 ----- 20-22
- Radius punches ----- 23-25

DIES

- Insert dies 30° ----- 26-28
- Insert dies 45° ----- 29
- Insert dies 60° ----- 30-31
- Insert dies 86° 88° 90° ----- 32-36
- Insert dies 84° ----- 37
- Insert hemming and offset tools ----- 38-39
- 2V Reversible dies ----- 40-42
- Large V dies ----- 43-45
- Hemming dies ----- 46-48

AFH ATC TOOLS

- AFH ATC punches ----- 49-53
- AFH ATC dies ----- 54-56

MARK FREE BENDING

- Scratch free tools and accessories ----- 57-60

HOLDERS, OTHER TOOLINGS AND ACCESSORIES

- Die holders ----- 61-65
- Punch holders ----- 66-68
- Other tools and accessories ----- 69-73
- Semistandard tools ----- 74
- Special tools ----- 75-78

Tables and graphs ----- 79-150



Punch quality:
throughhardened from hot formed steel

- for long lasting high precision.
- surface hardness: **45-50 HRC**
- body strength: **1500 N/mm²**



Die quality : AMANIT®

- highest wear resistance on tool surface (**HRC 60-65**)
- low friction on the shoulder radii
- highest strength of the body - **1150 N/mm²**
- corrosion resistance

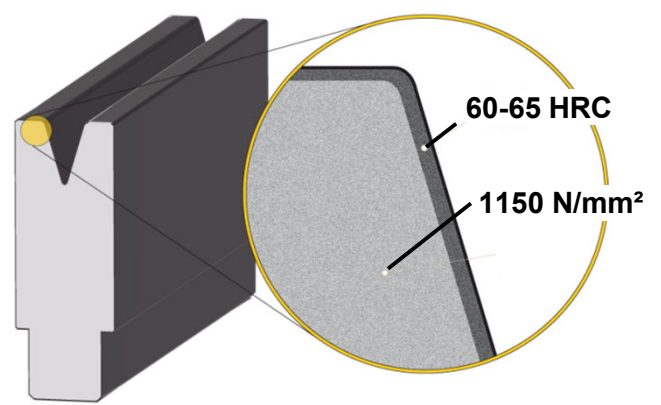

Bi-S & Bi-L angle sensors:

Requires Amada AFH 1V dies to ensure High-quality bending operations

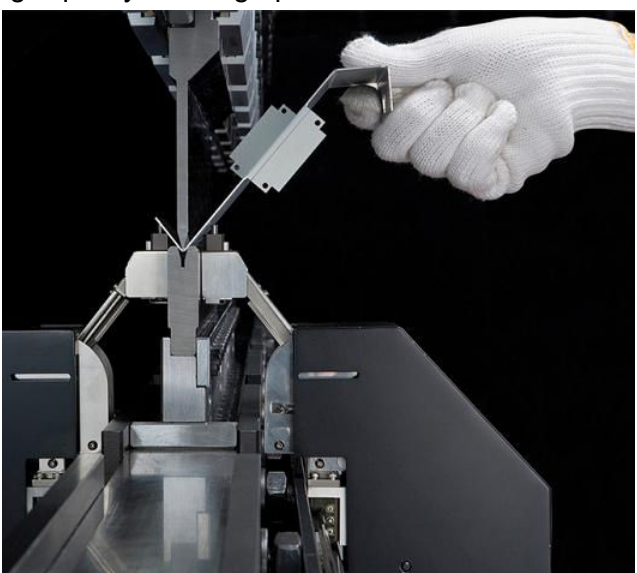

Software integration:

Using AFH tools you can rely on VPSS software, to suggest best tool auto-assignments for completing your complex parts.

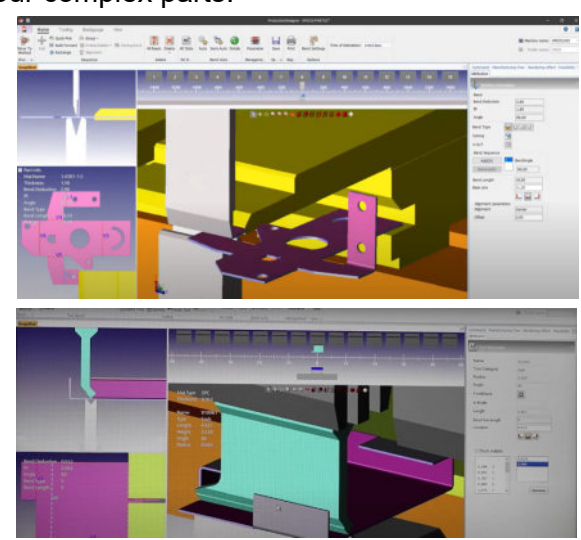

Standard tooling lengths:

L = 835mm ; S = 415mm ; Sectionalized = 800mm

Sectionalization :



Punch: 100ear; 10; 2 X 15; 20; 40; 50; 150; 300; 100ear = 800mm



Die : 100; 10; 2 X 15; 20; 40; 50; 150; 400 = 800mm

Special lengths are available at additional cost.

We are aware of the necessity to manufacture high professional tools. All our activities are targeting precision, performance and safety. Being the first company offering standard tools for unlimited staged bending or offering standard tools for more process reliability while boosting tool life with AMANIT™, we repeatedly demonstrated that all our activities are developed in close coordination with our customers, meeting the demands of the “best in class”.

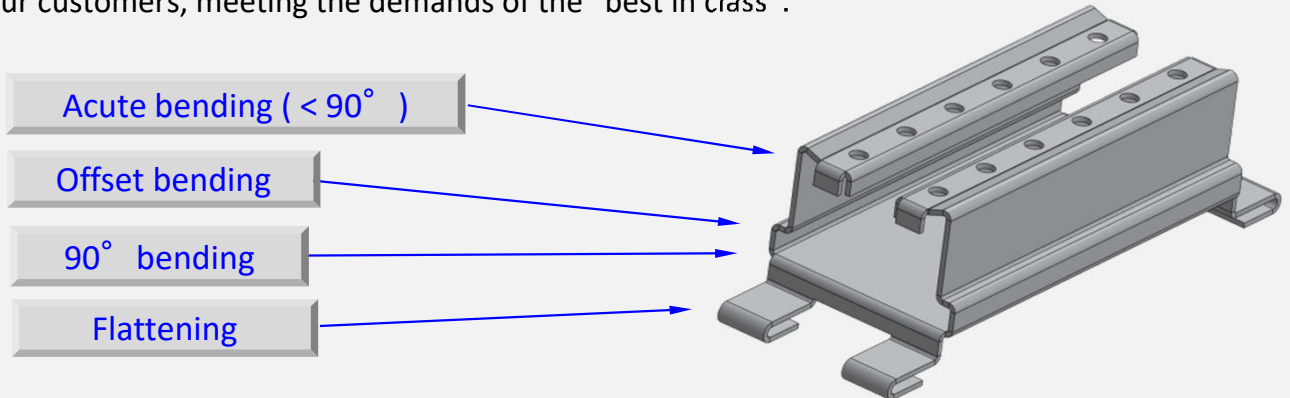

For example, the manufacturing of above electronic chassis requires 90-degree bends, acute bends, hems and offset bends. Using traditional bending tools with differing heights, the operator would set up his press brake several times, handling the same part again and again.

Our AFH tools are designed in order to enable the operator to setup multiple bends within one brake bed, operator being more focused on his sheet part by enjoying trouble-free, unlimited staging possibilities. Our staged dies are offering usual stage bending in combination with acute bending, hemming and offset bending by simplifying bending technology for small and complex parts.

Our punches are categorized into four levels, depending on their operating height. **H70mm, H90mm, H120mm and H160mm.**

Example for tooling choice with H120 punches

84°; 86°; 88°; 90° R0,6 - R3	60° R0,6 - R6	30° R0,6 - R4	R R7 - R50	Z Z3 - Z10
V4 - V40	V6 - V25	V6 - V25	...V40	tools usable as punches and as dies



With stage bending, the operator can carry a complex part through multiple bends on different tool sets within one brake bed, and finish it after just one handling.

All tools for these options are available from stock.

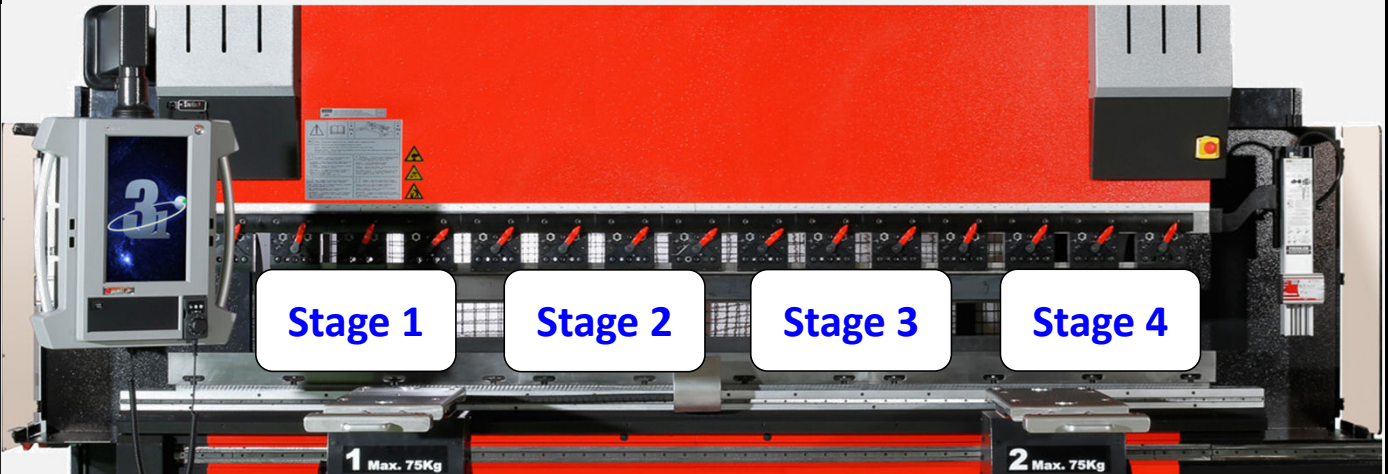

Stage engineering for sheet parts needing only 90° bends :

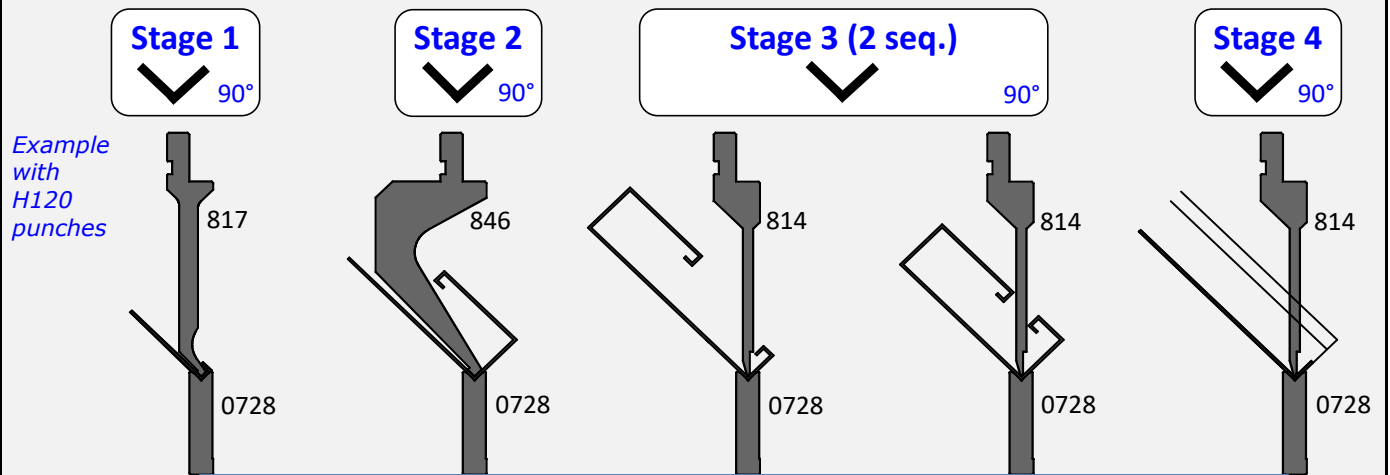

- Note:
- for perfect staging please use H120 punches (alternatively H90 or H160)
 - all H120 - R0,6 punches are manufactured on same height (AFH principle)
 - please use H60 dies from type 070... to 088...
 - all above tools are able to build unlimited stages for 90° bends

Stage engineering for parts needing multiple bends :

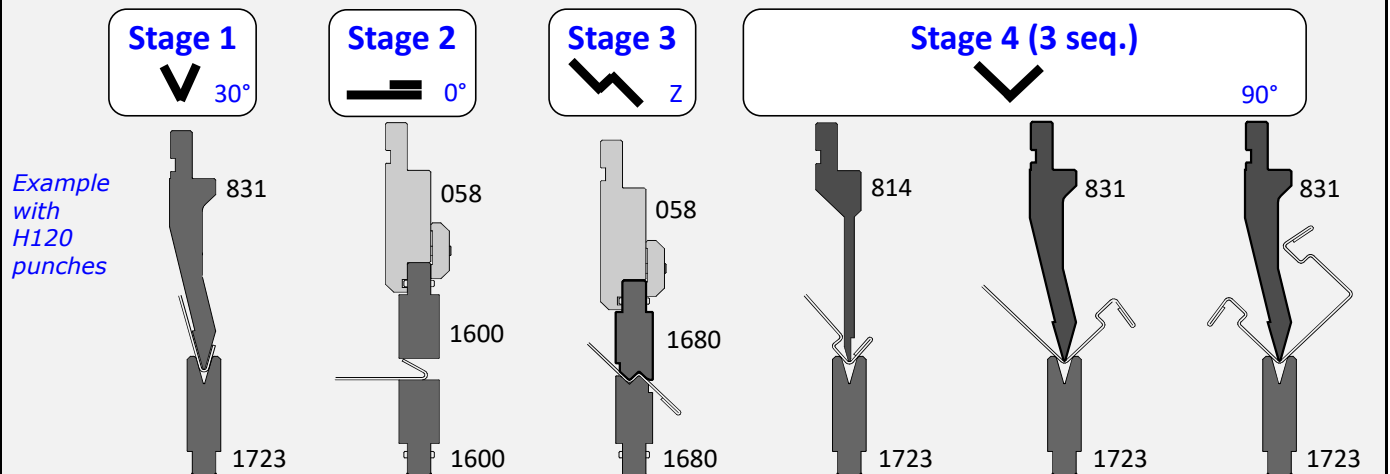

- Note:
- for perfect staging please use H120 punches (alternatively H90 or H160)
 - please use dies from type 170... to 182...
 - all staged dies paired with H120 (alternatively H90 or H160) punches have common shut height making brake setup fast and stage bending easy
 - Common shut height tools available for 90°, sharp angle, hemming and offset bending

■ Dies prepared for minimal offset values:

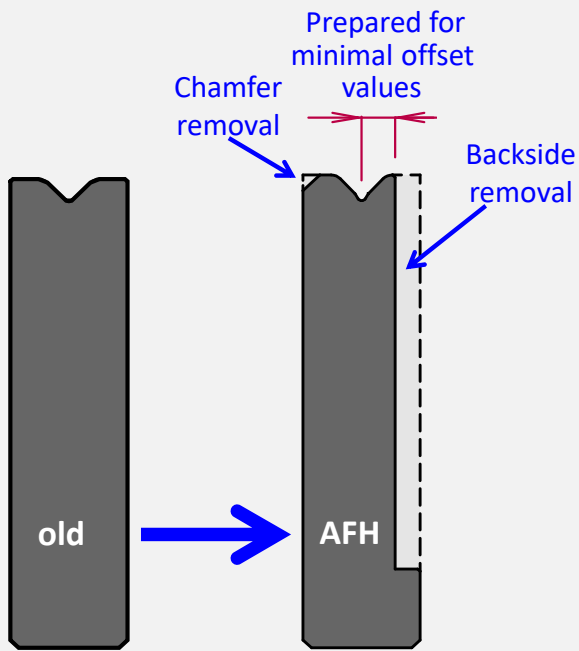

Examples:

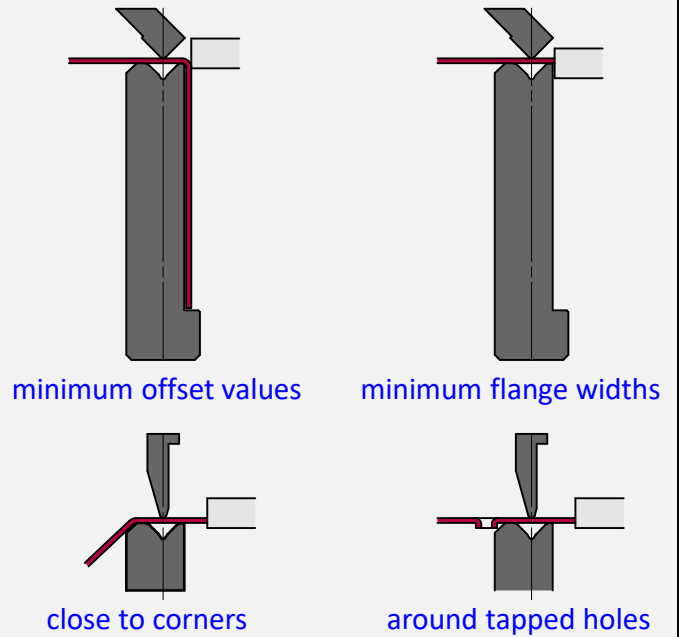

■ Use with angle measurement system :

To ensure the highest part accuracy from the very first bend, an angle measuring and correcting system like BIS or BIL is necessary. All generated bend correction data from our angle measuring systems are calibrated with AFH tools.

- Enlarges return bend area around the punch
- Eases software success of Dr.ABE BEND
- Prevents mistakes due to same punch height
- Quick change in combination with AGRIP clamps



Combination of tool-sets per machine length

Machine length m				Tool-set length mm
	835 solid	415 solid	800 sect.	
1,2	1	1		1.250
		3		1.245
		1	1	1.215
	1		1	1.635
2	2	1		2.085
	2		1	2.470
	1	1	1	2.050
		3	1	2.045
	1	2	1	2.465
2,5	3			2.505
	2	2		2.500
	2		1	2.470
	2	1	1	2.885
	1	2	1	2.465
	1		2	2.435
	1	3	1	2.880
	1	1	2	2.850
3	3	1		2.920
	3		1	3.305
	2	3		2.915
	2	2	1	3.300
	2	1	1	2.885
	2		2	3.270
	1	5		2.910
	1	4	1	3.295
	1	2	2	3.265
		4	2	3.260
4	5			4.175
	4	2		4.170
	4	1	1	4.555
	4		1	4.140
	3	3	1	4.550
	3	2	1	4.135
	3	1	2	4.520
	3		2	4.105
	2	2	2	4.100

Worldwide sales organization, ensuring excellent availability all over the world, and guaranteeing outstanding service for the customers

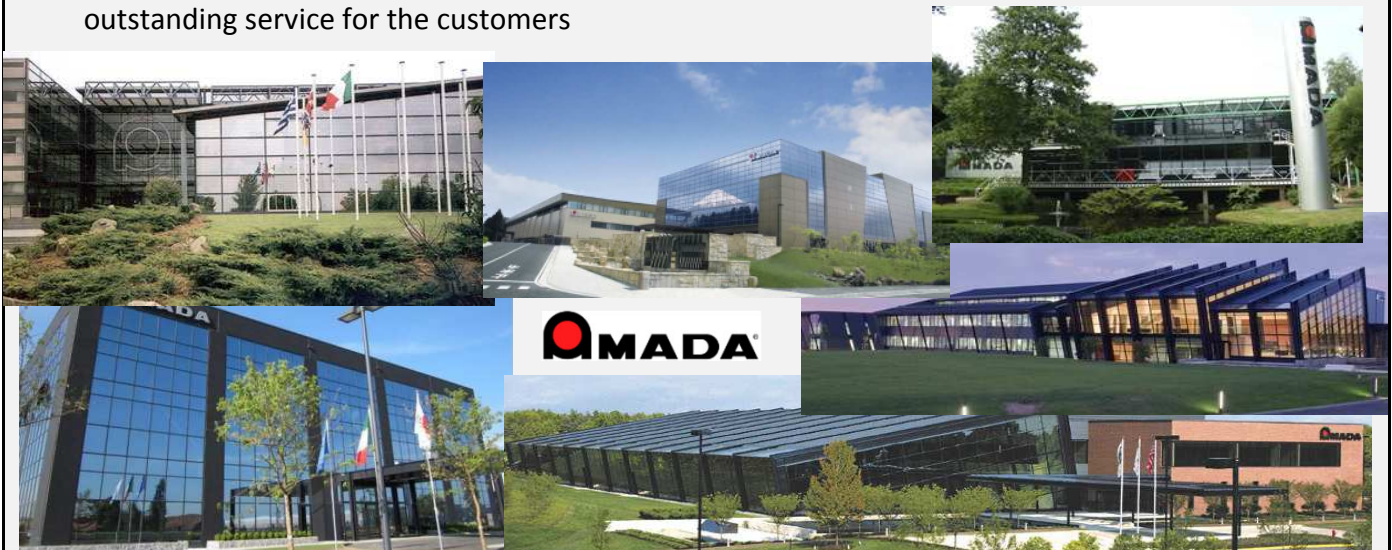

AFH Standard Punch 804 (9 mm tip)

Punch 804 replaces old punches S51; S52; A04; A16

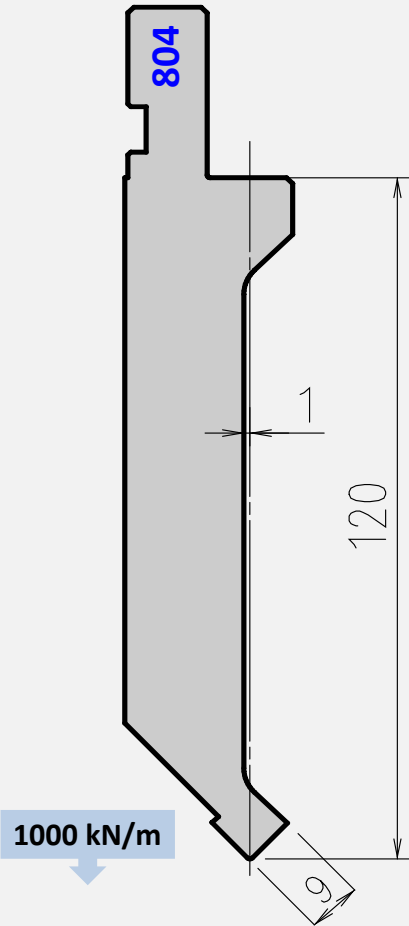

Tool angle	Tip radius	Length mm	Item No.	Weight Kg
86°	R0.6	835	ES8048061	17,1
		415	ES8048062	8,5
		800 Sect	ES8048063	15,1
	R1.5	835	ES8048151	17,1
		415	ES8048152	8,5
		800 Sect	ES8048153	15,1
	R3	835	ES8048301	17,1
		415	ES8048302	8,5
		800 Sect	ES8048303	15,1
88°	R0.6	835	ES8047061	17,1
		415	ES8047062	8,5
		800 Sect	ES8047063	15,1
90°	R0.6	835	ES8049061	17,1
		415	ES8049062	8,5
		800 Sect	ES8049063	15,1

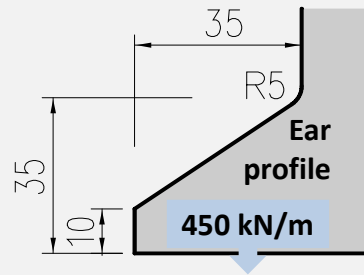

AFH Gooseneck Punch 847 (9 mm tip)

Punch 847 replaces old punches 45; 47; S55; S56; A47; A48.

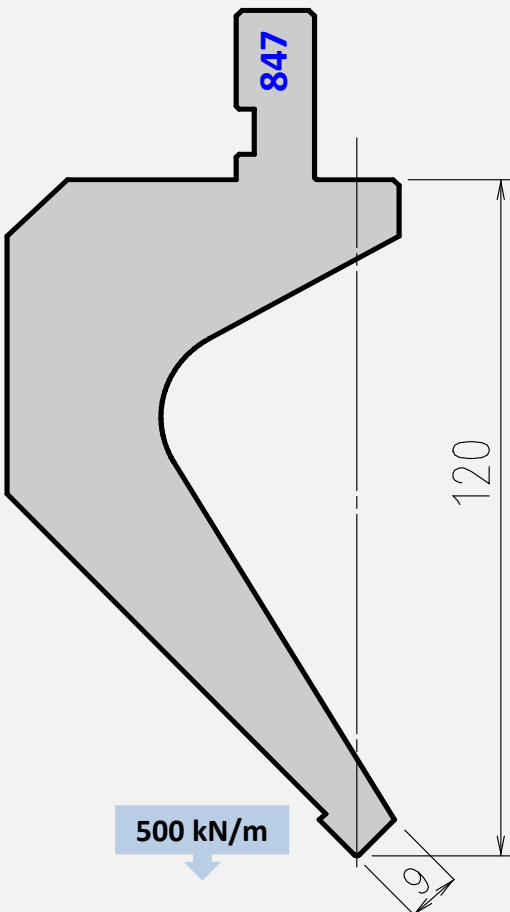

Tool angle	Tip radius	Length mm	Item No.	Weight Kg
86°	R0.6	835	ES8478061	25,2
		415	ES8478062	12,5
		800 Sect	ES8478063	22,2
	R1.5	835	ES8478151	25,2
		415	ES8478152	12,5
		800 Sect	ES8478153	22,2
	R3	835	ES8478301	25,2
		415	ES8478302	12,5
		800 Sect	ES8478303	22,2
88°	R0.6	835	ES8477061	25,2
		415	ES8477062	12,5
		800 Sect	ES8477063	22,2
90°	R0.6	835	ES8479061	25,2
		415	ES8479062	12,5
		800 Sect	ES8479063	22,2

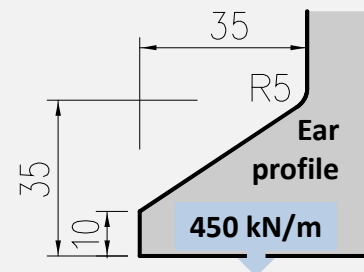

AFH Sash Punch 820 (8 mm tip)

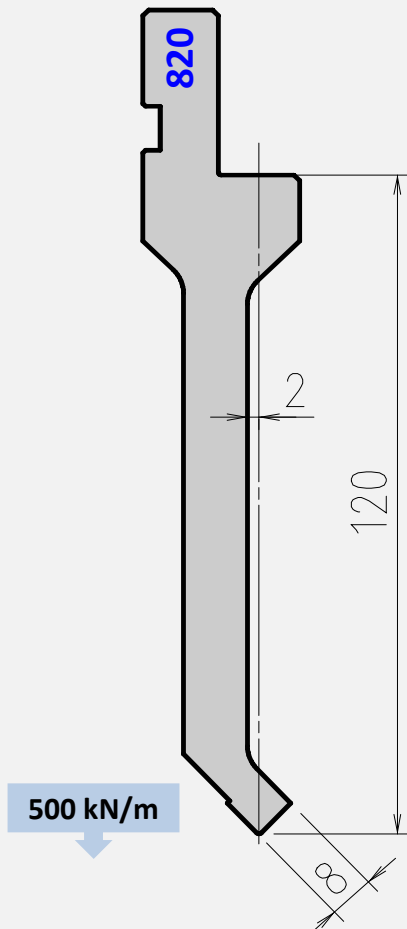

Tool angle	Tip radius	Length mm	Item No.	Weight Kg
86°	R0.6	835	ES8208061	11,7
		415	ES8208062	5,8
		800 Sect	ES8208063	10,5
	R1.5	835	ES8208151	11,7
		415	ES8208152	5,8
		800 Sect	ES8208153	10,5
88°	R0.6	835	ES8207061	11,7
		415	ES8207062	5,8
		800 Sect	ES8207063	10,5

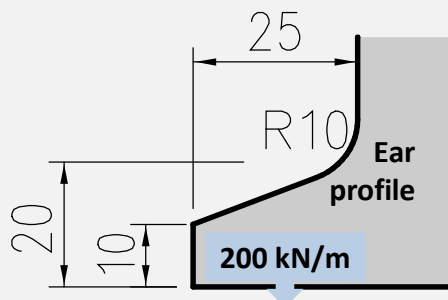

AFH Sash Punch 817 (4 mm tip)

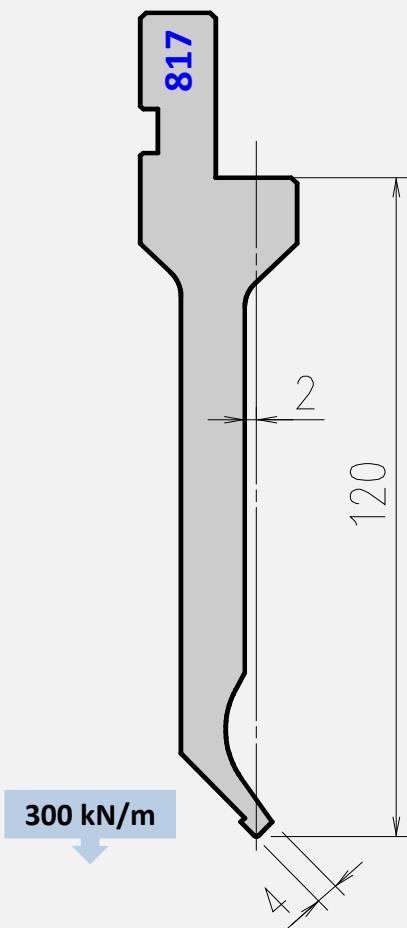

Tool angle	Tip radius	Length mm	Item No.	Weight Kg
86°	R0.6	835	ES8178061	11,1
		415	ES8178062	5,5
		800 Sect	ES8178063	10,4
88°	R0.6	835	ES8177061	11,1
		415	ES8177062	5,5
		800 Sect	ES8177063	10,4

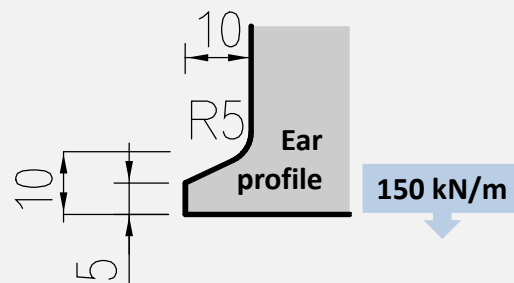

AFH Thin Gooseneck Punch 846 (6 mm tip)

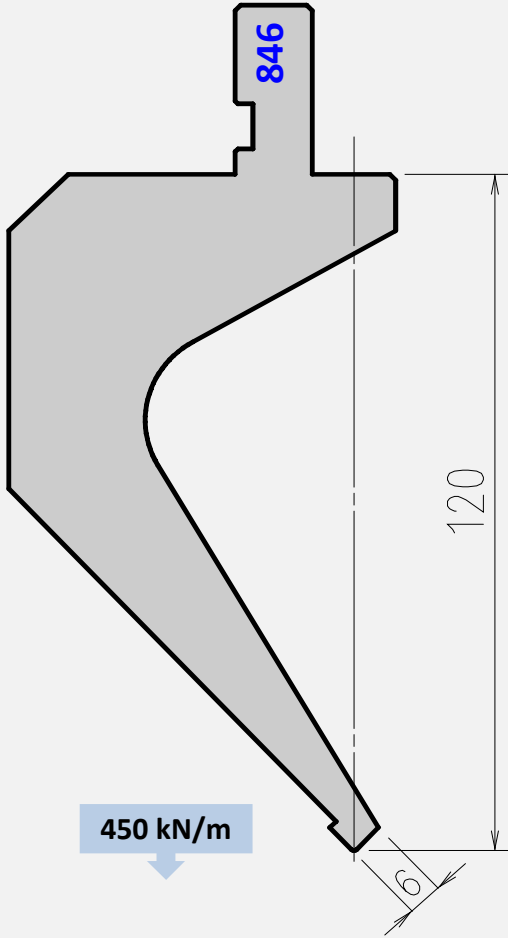

Tool angle	Tip radius	Length mm	Item No.	Weight Kg
86°	R0.6	835	ES8468061	23,3
		415	ES8468062	11,6
		800 Sect	ES8468063	20,5
88°	R0.6	835	ES8467061	23,3
		415	ES8467062	11,6
		800 Sect	ES8467063	20,5

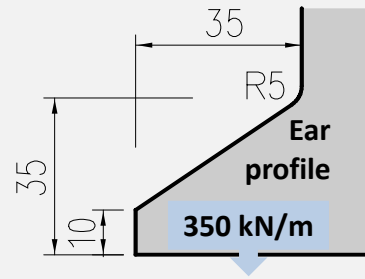

AFH Acute Sash Punch 840

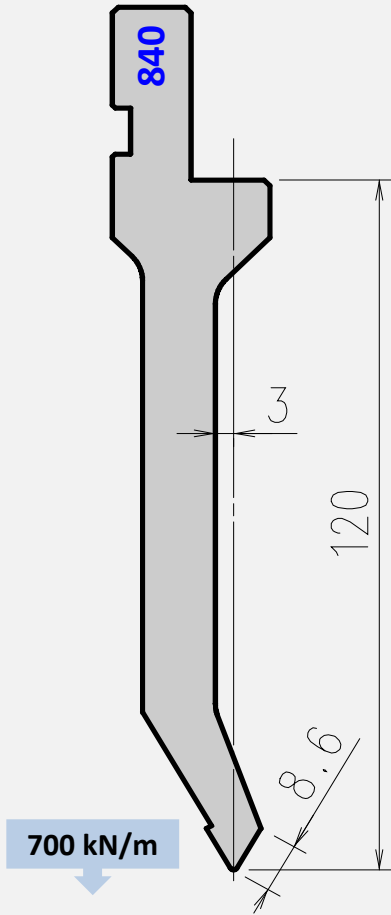

Tool angle	Tip radius	Length mm	Item No.	Weight Kg
60°	R0.6	835	ES8406061	12,4
		415	ES8406062	6,2
		800 Sect	ES8406063	11,0
	R1.5	835	ES8406151	12,4
		415	ES8406152	6,2
		800 Sect	ES8406153	11,0

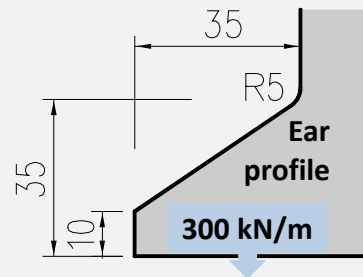

AFH Gooseneck Punch 841

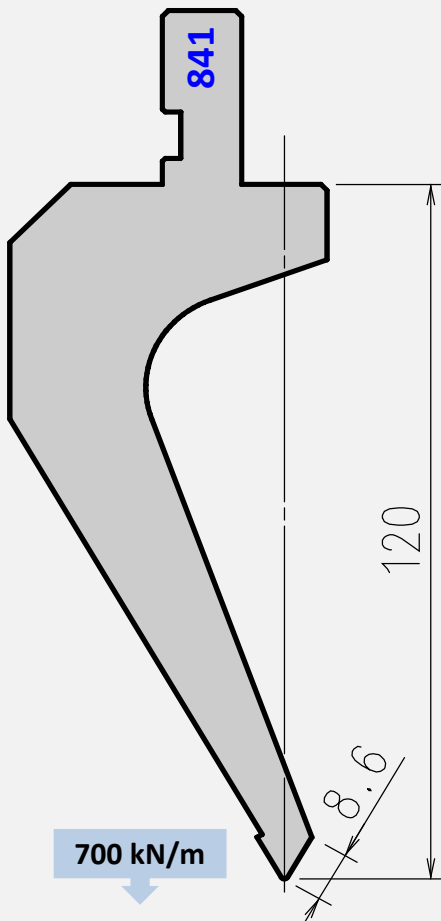

Tool angle	Tip radius	Length mm	Item No.	Weight Kg
60°	R0.6	835	ES8416061	19,2
		415	ES8416062	9,5
		800 Sect	ES8416063	16,9
	R1.5	835	ES8416151	19,2
		415	ES8416152	9,5
		800 Sect	ES8416153	16,9

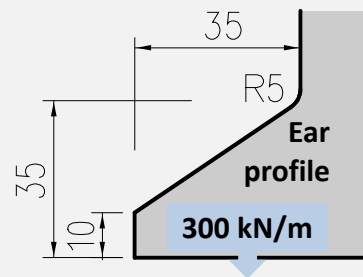

AFH Acute Angle Punch 814

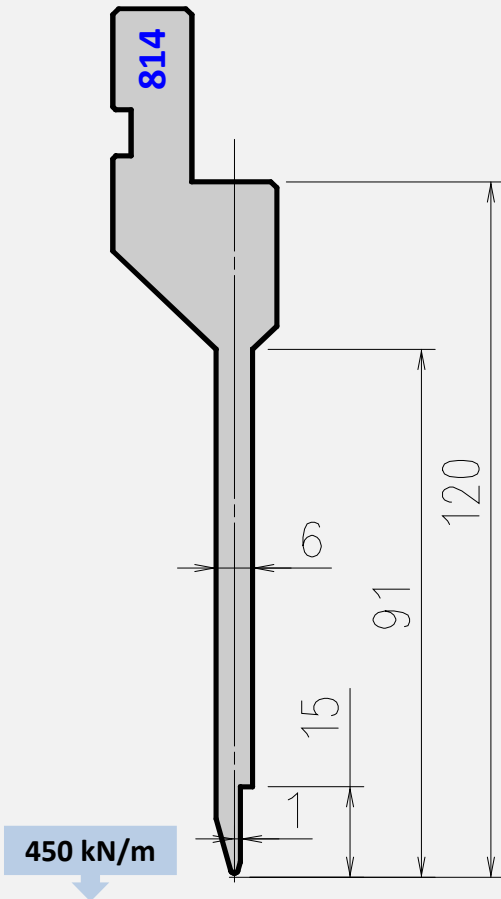

Tool angle	Tip radius	Length mm	Item No.	Weight Kg
30°	R0.6	835	ES8143061	9,8
		415	ES8143062	4,9
		800 Sect	ES8143063	8,8

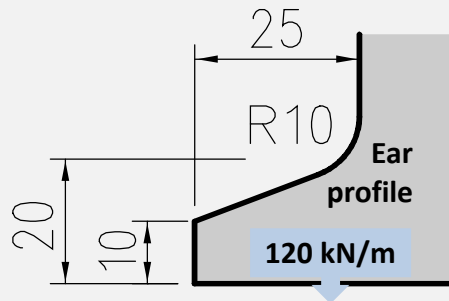

AFH Hemming Punch 831

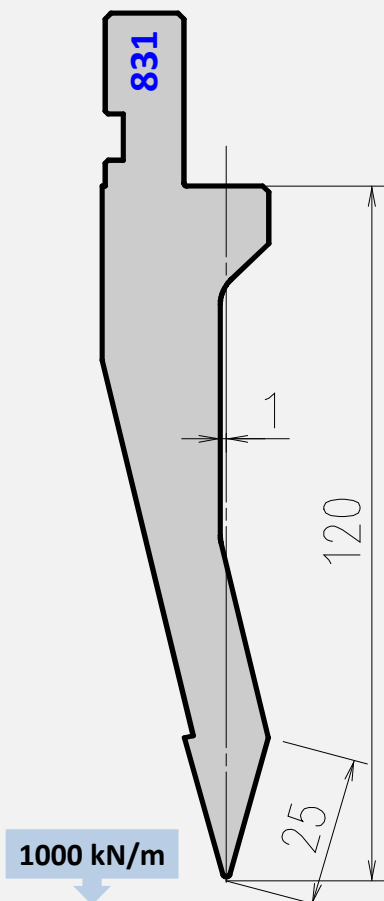

Tool angle	Tip radius	Length mm	Item No.	Weight Kg
26°	R0.6	835	ES8312061	13,9
		415	ES8312062	6,9
		800 Sect	ES8312063	12,7
30°	R0.6	835	ES8313061	14,1
		415	ES8313062	7,0
		800 Sect	ES8313063	12,9
	R1.5	835	ES8313151	14,1
		415	ES8313152	7,0
		800 Sect	ES8313153	12,9
	R3	835	ES8313301	13,9
		415	ES8313302	6,9
		800 Sect	ES8313303	12,7
R4	835	ES8313401	13,9	
	415	ES8313402	6,9	
	800 Sect	ES8313403	12,7	

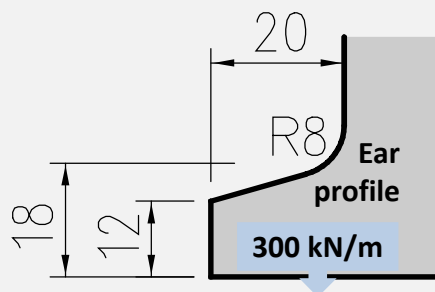

AFH Straight Punch 803

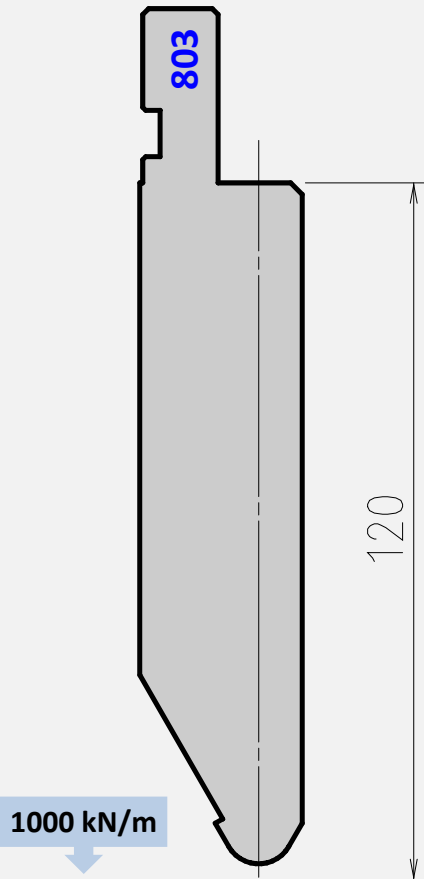

Tool angle	Tip radius	Length mm	Item No.	Weight Kg
60°	R5.0	835	ES8036501	21,8
		415	ES8036502	10,8
		800 Sect	ES8036503	19,5
	R6.0	835	ES8036601	21,8
		415	ES8036602	10,8
		800 Sect	ES8036603	19,5

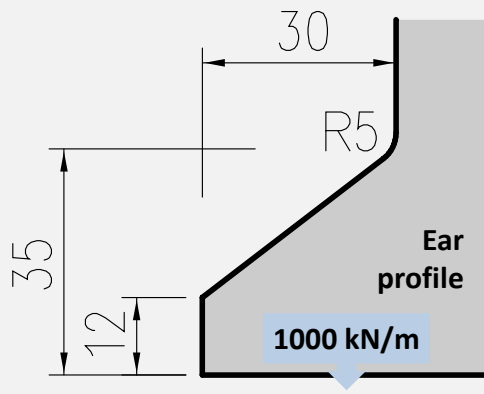

AFH Flattening Punch 822

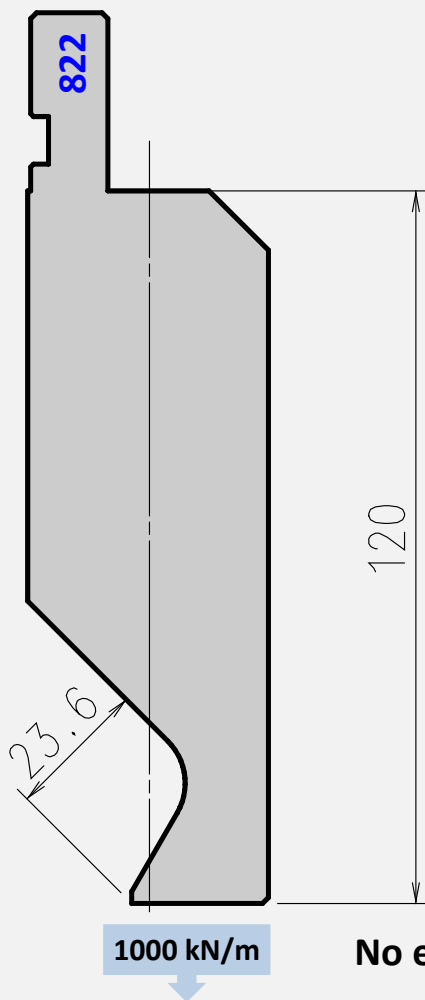

	Length mm	Item No.	Weight Kg
Flattening	835	ES8220001	27,8
	415	ES8220002	13,8
	800 Sect	ES8220003	26,6

Notes:

1. Flattening involves high thrust forces, therefore it's sequence always needs an intermittent stroke
2. Punch 822 to be used mainly for harder flattening operations in combination with ED0129 die and unlimited lengths
3. Beak shaped tip allows close to flange flattening
4. As staging punch to be used only for short flattening lengths up to 100mm. Intermittent stroke needed

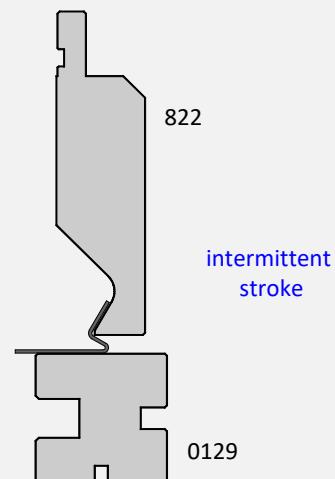

No ears

AFH Standard Punch 704 (9 mm tip)

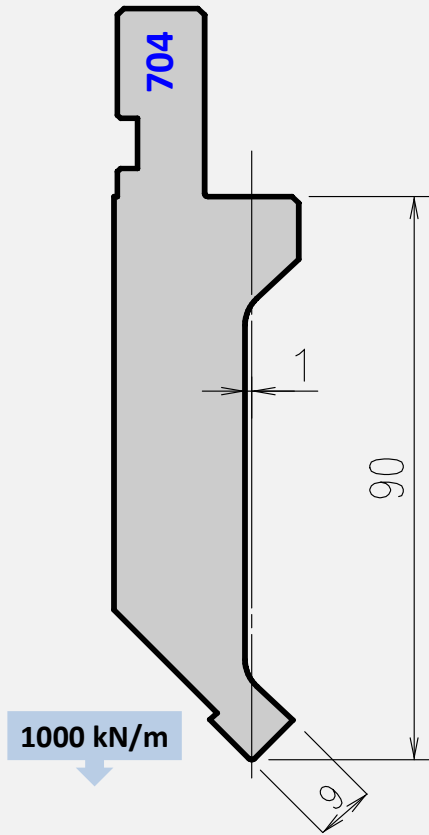

Tool angle	Tip radius	Length mm	Item No.	Weight Kg
86°	R0.6	835	ES7048061	13,3
		415	ES7048062	6,6
		800 Sect	ES7048063	11,8
	R1.5	835	ES7048151	13,3
		415	ES7048152	6,6
		800 Sect	ES7048153	11,8
	R3	835	ES7048301	13,3
		415	ES7048302	6,6
		800 Sect	ES7048303	11,8
88°	R0.6	835	ES7047061	13,3
		415	ES7047062	6,6
		800 Sect	ES7047063	11,8
90°	R0.6	835	ES7049061	13,3
		415	ES7049062	6,6
		800 Sect	ES7049063	11,8

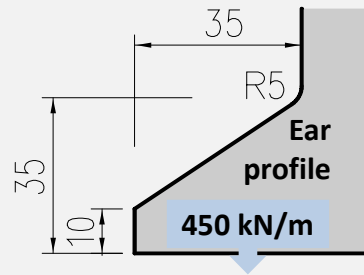

AFH Gooseneck Punch 747 (9 mm tip)

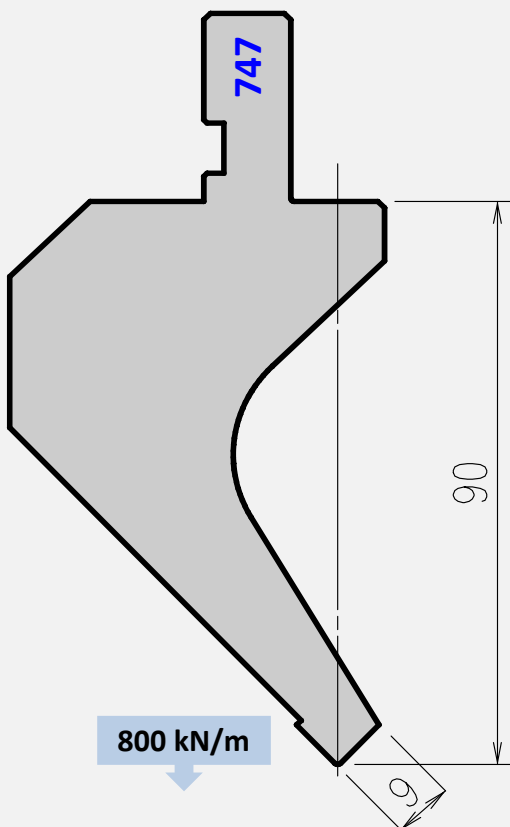

Tool angle	Tip radius	Length mm	Item No.	Weight Kg
86°	R0.6	835	ES7478061	19,4
		415	ES7478062	9,6
		800 Sect	ES7478063	17,1
	R1.5	835	ES7478151	19,4
		415	ES7478152	9,6
		800 Sect	ES7478153	17,1
	R3	835	ES7478301	19,4
		415	ES7478302	9,6
		800 Sect	ES7478303	17,1
88°	R0.6	835	ES7477061	19,4
		415	ES7477062	9,6
		800 Sect	ES7477063	17,1
90°	R0.6	835	ES7479061	19,4
		415	ES7479062	9,6
		800 Sect	ES7479063	17,1

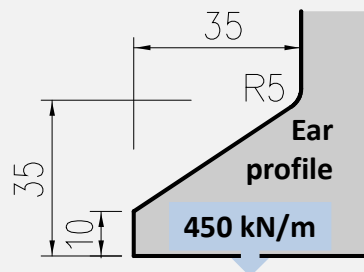

AFH Sash Punch 720 (8 mm tip)

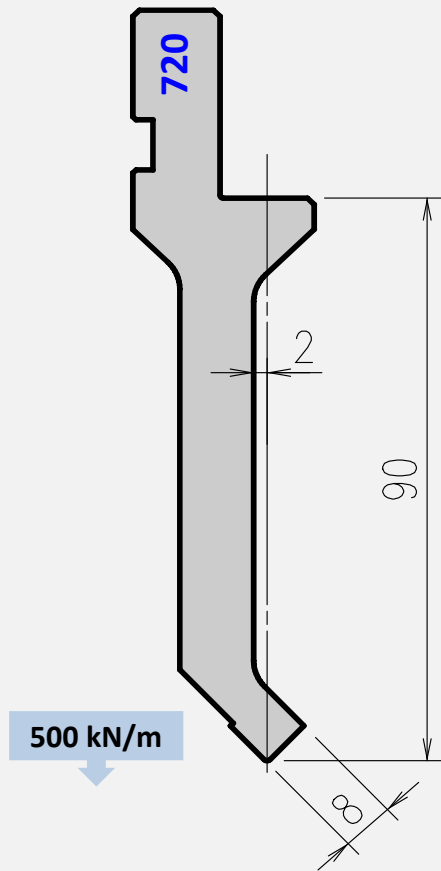

Tool angle	Tip radius	Length mm	Item No.	Weight Kg
86°	R0.6	835	ES7208061	9,1
		415	ES7208062	4,5
		800 Sect	ES7208063	8,2
	R1.5	835	ES7208151	9,1
		415	ES7208152	4,5
		800 Sect	ES7208153	8,2
88°	R0.6	835	ES7207061	9,1
		415	ES7207062	4,5
		800 Sect	ES7207063	8,2

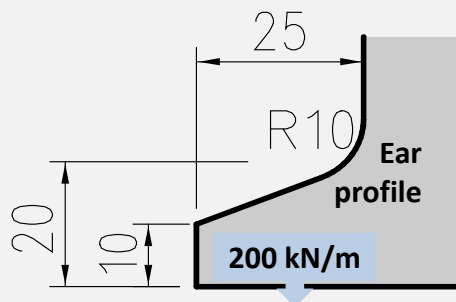

AFH Thin Gooseneck Punch 746 (6 mm tip)

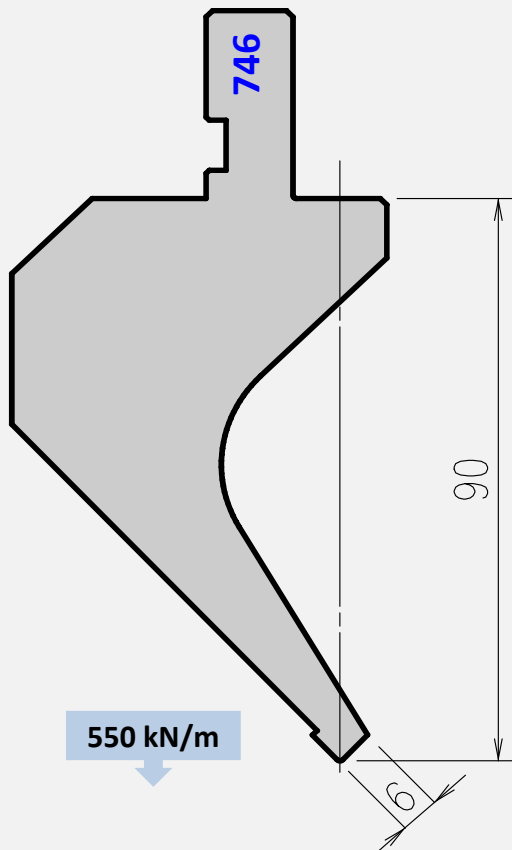

Tool angle	Tip radius	Length mm	Item No.	Weight Kg
86°	R0.6	835	ES7468061	18,3
		415	ES7468062	9,1
		800 Sect	ES7468063	16,1
88°	R0.6	835	ES7467061	18,3
		415	ES7467062	9,1
		800 Sect	ES7467063	16,1

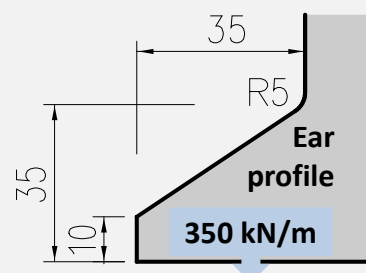

AFH Standard Punch 717 (4 mm tip)

Tool angle	Tip radius	Length mm	Item No.	Weight Kg
86°	R0.6	835	ES7178061	11,8
		415	ES7178062	5,8
		800 Sect	ES7178063	11,0
88°	R0.6	835	ES7177061	11,8
		415	ES7177062	5,8
		800 Sect	ES7177063	11,0

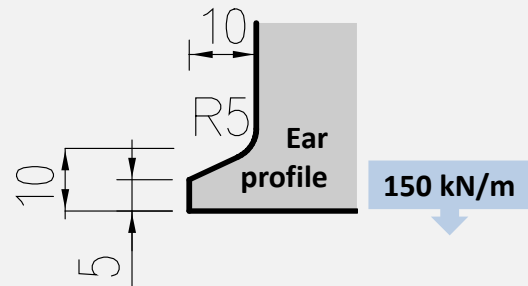
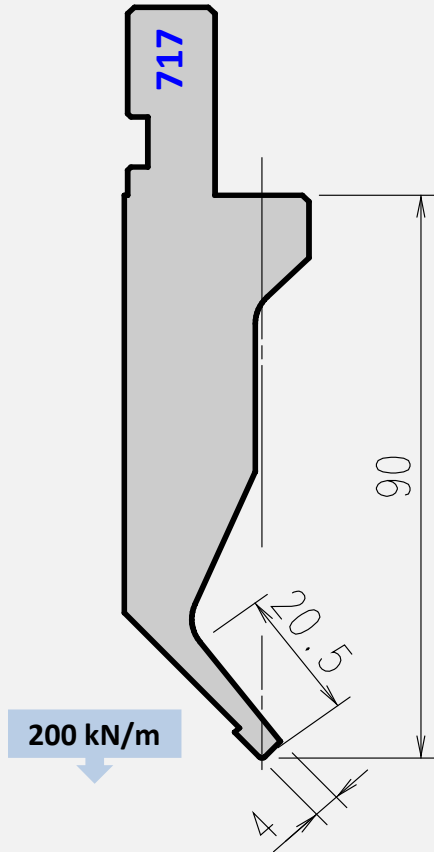

AFH Acute Angle Punch 713

Tool angle	Tip radius	Length mm	Item No.	Weight Kg
30°	R0.6	835	ES7133061	8,7
		415	ES7133062	4,3
		800 Sect	ES7133063	7,9

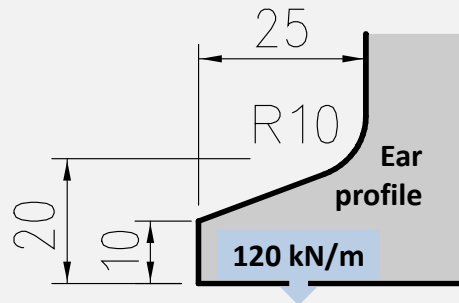
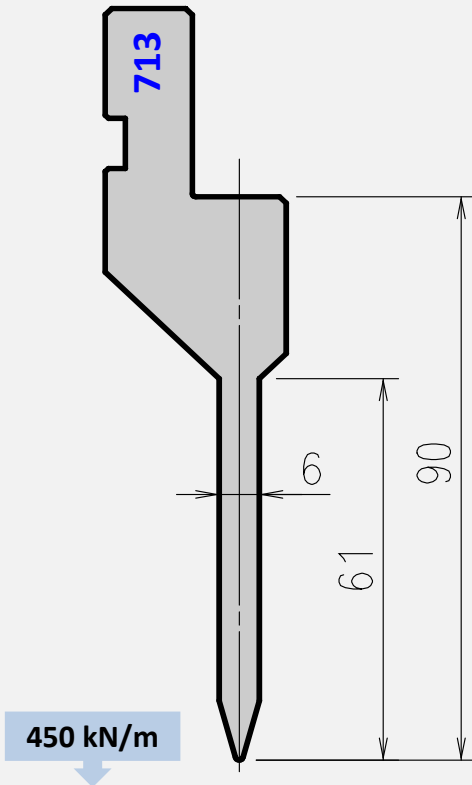

AFH Hemming Punch 731

Tool angle	Tip radius	Length mm	Item No.	Weight Kg
30°	R0.6	835	ES7313061	10,1
		415	ES7313062	5,0
		800 Sect	ES7313063	9,2
	R1.5	835	ES7313151	10,1
		415	ES7313152	5,0
		800 Sect	ES7313153	9,2
	R3	835	ES7313301	10,1
		415	ES7313302	5,0
		800 Sect	ES7313303	9,2

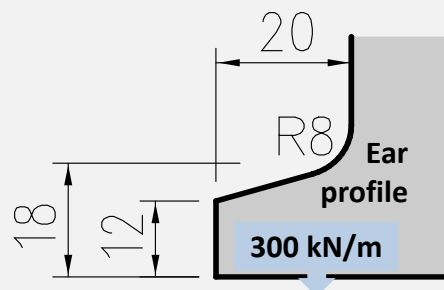
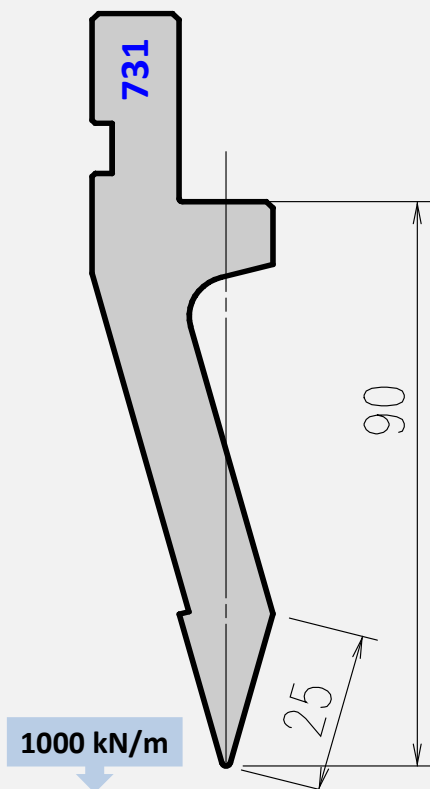

AFH Std. Punch 904

AFH Acute Angle Punch 914

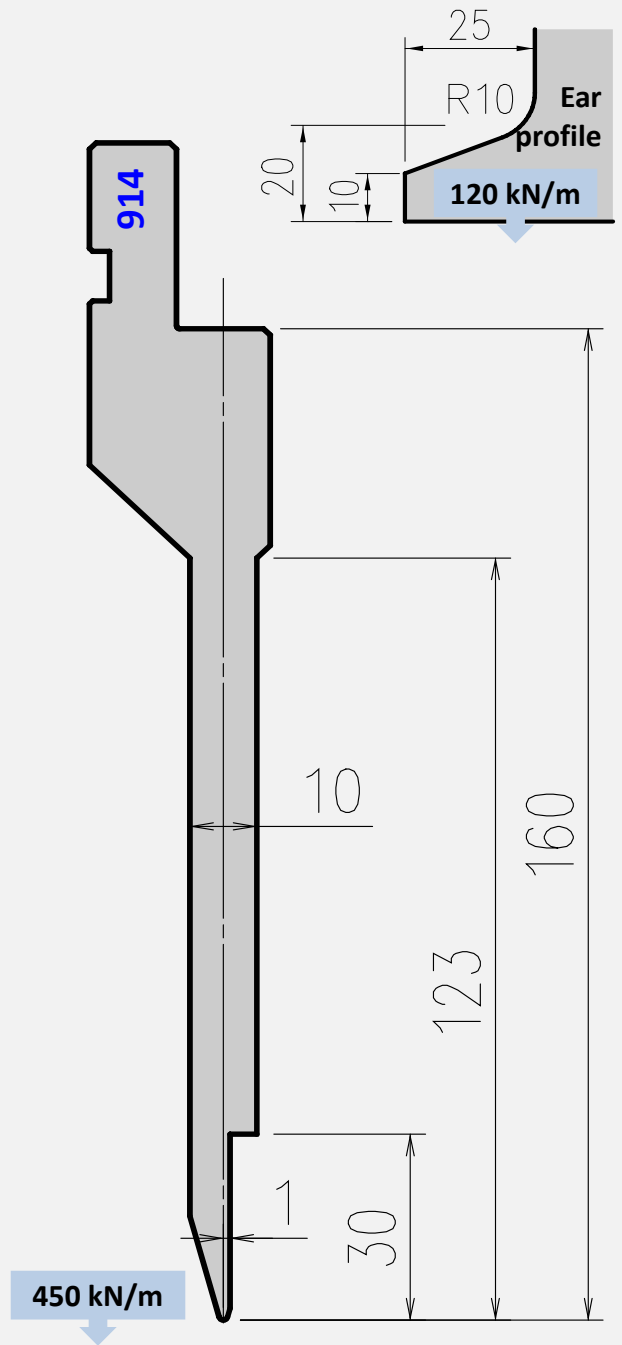
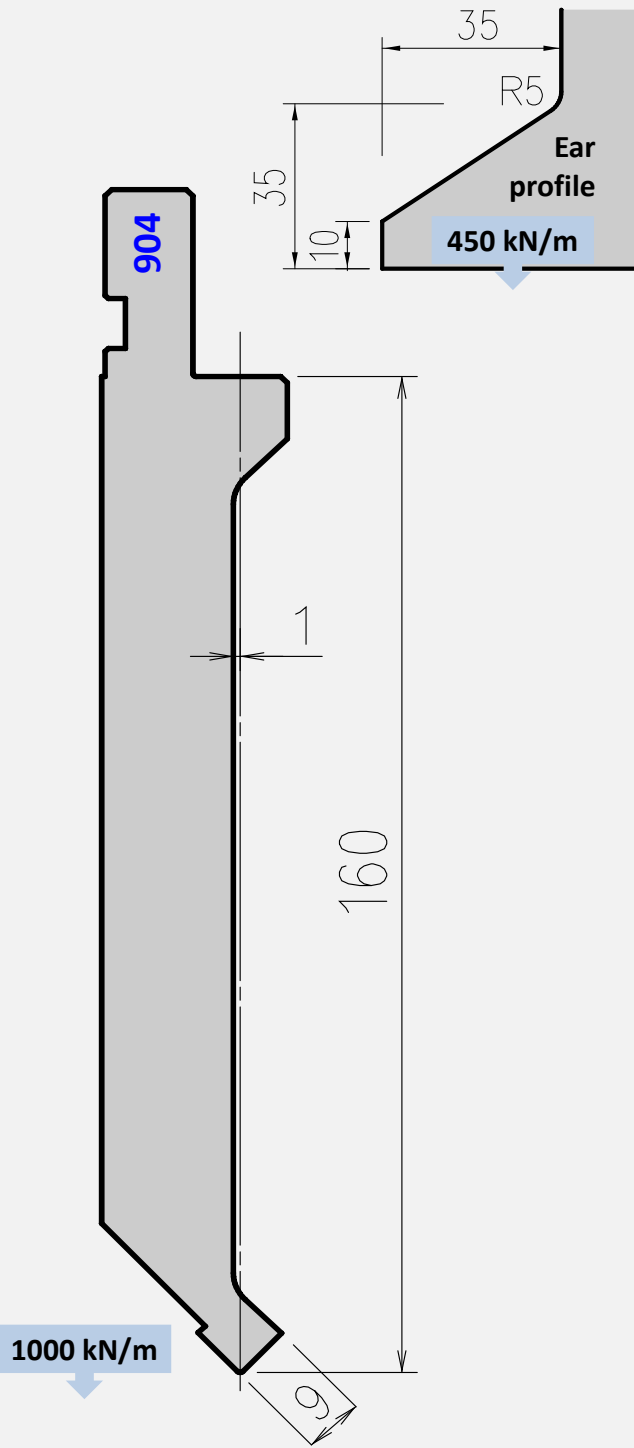

Tool angle	Tip radius	Length mm	Item No.	Wt. Kg
86°	R0.6	835	ES9048061	22,1
		415	ES9048062	11,0
		800 Sect	ES9048063	19,5
	R1.5	835	ES9048151	22,1
		415	ES9048152	11,0
		800 Sect	ES9048153	19,5
	R3	835	ES9048301	22,1
		415	ES9048302	11,0
		800 Sect	ES9048303	19,5
88°	R0.6	835	ES9047061	22,1
		415	ES9047062	11,0
		800 Sect	ES9047063	19,5

Tool angle	Tip radius	Length mm	Item No.	Wt. Kg
30°	R0.6	835	ES9143061	15,1
		415	ES9143062	7,5
		800 Sect	ES9143063	13,6

AFH Gooseneck Punch 947

Tool angle	Tip radius	Length mm	Item No.	Weight Kg
86°	R0.6	835	ES9478061	39,1
		415	ES9478062	19,4
		800 Sect	ES9478063	34,3
	R1.5	835	ES9478151	39,1
		415	ES9478152	19,4
		800 Sect	ES9478153	34,3
	R3	835	ES9478301	39,1
		415	ES9478302	19,4
		800 Sect	ES9478303	34,3
88°	R0.6	835	ES9477061	39,1
		415	ES9477062	19,4
		800 Sect	ES9477063	34,3

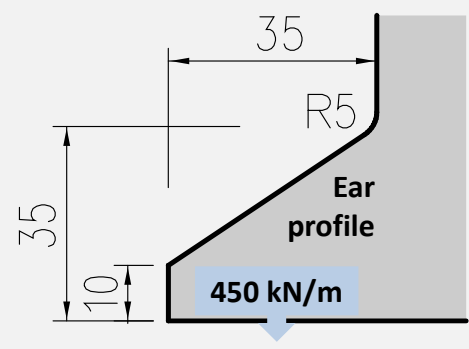
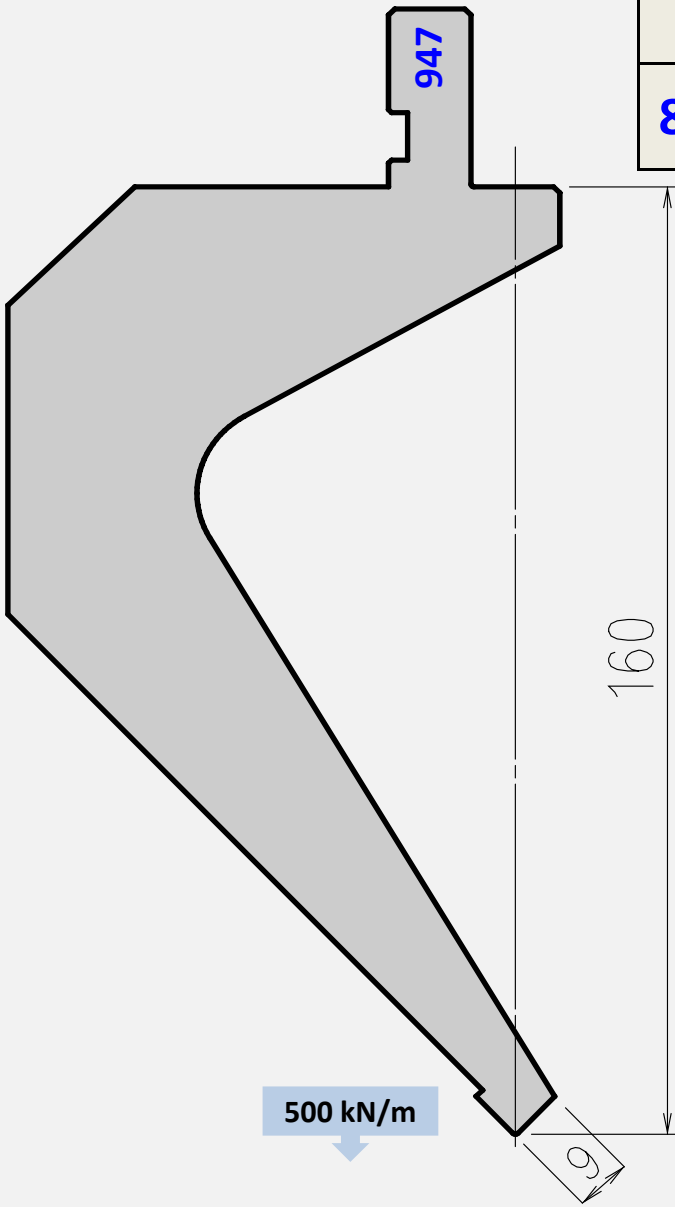

Standard Punch 604 (9 mm tip)

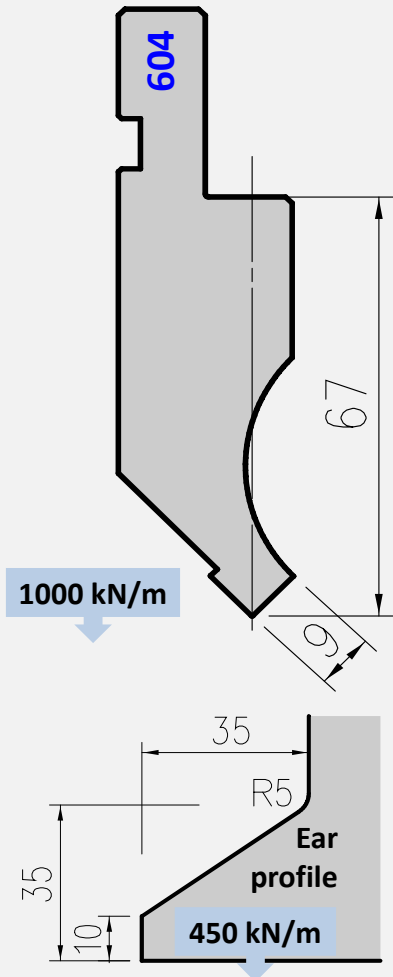

Tool angle	Tip radius	Length mm	Item No.	Weight Kg
88°	R0.2	835	ES6047021	11,0
		415	ES6047022	5,5
		800 Sect	ES6047023	9,7
	R0.6	835	ES6047061	11,0
		415	ES6047062	5,5
		800 Sect	ES6047063	9,7
	R0.8	835	ES6047081	11,0
		415	ES6047082	5,5
		800 Sect	ES6047083	9,7
	R1.5	835	ES6047151	11,0
		415	ES6047152	5,5
		800 Sect	ES6047153	9,7
R3	835	ES6047301	11,0	
	415	ES6047302	5,5	
	800 Sect	ES6047303	9,7	
90°	R0.2	835	ES6049021	11,0
		415	ES6049022	5,5
		800 Sect	ES6049023	9,7
	R0.6	835	ES6049061	11,0
		415	ES6049062	5,5
		800 Sect	ES6049063	9,7

Standard Punch 617 (4 mm tip)

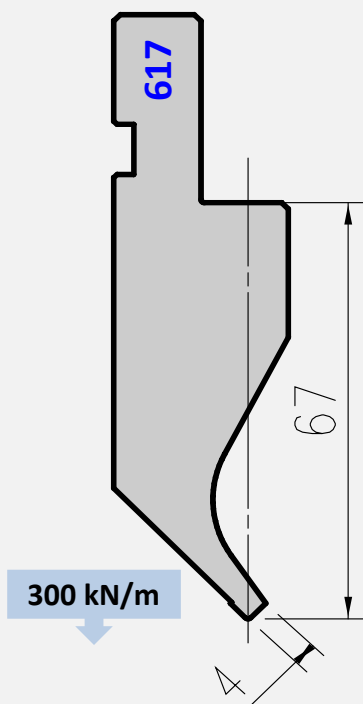

Tool angle	Tip radius	Length mm	Item No.	Weight Kg
88°	R0.2	835	ES6177021	10,2
		415	ES6177022	5,1
		800 Sect	ES6177023	9,1
	R0.6	835	ES6177061	10,2
		415	ES6177062	5,1
		800 Sect	ES6177063	9,1
R0.8	835	ES6177081	10,2	
	415	ES6177082	5,1	
	800 Sect	ES6177083	9,1	
90°	R0.2	835	ES6179021	10,2
		415	ES6179022	5,1
		800 Sect	ES6179023	9,1
	R0.6	835	ES6179061	10,2
		415	ES6179062	5,1
		800 Sect	ES6179063	9,1

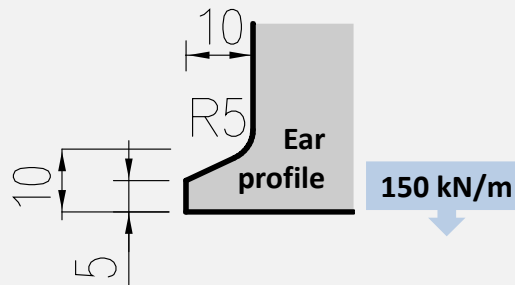

Straight Punch 603

Tool angle	Tip radius	Length mm	Item No.	Weight Kg
60°	R6.0	835	ES6036601	12,3
		415	ES6036602	6,1
		800 Sect	ES6036603	11,1

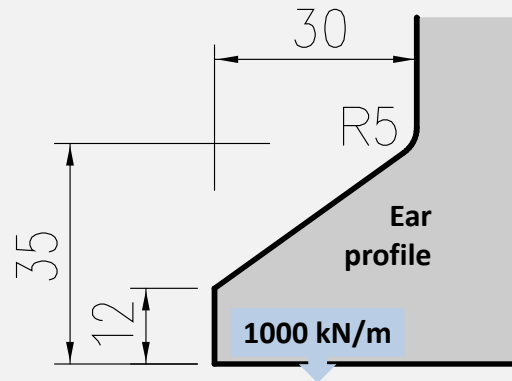
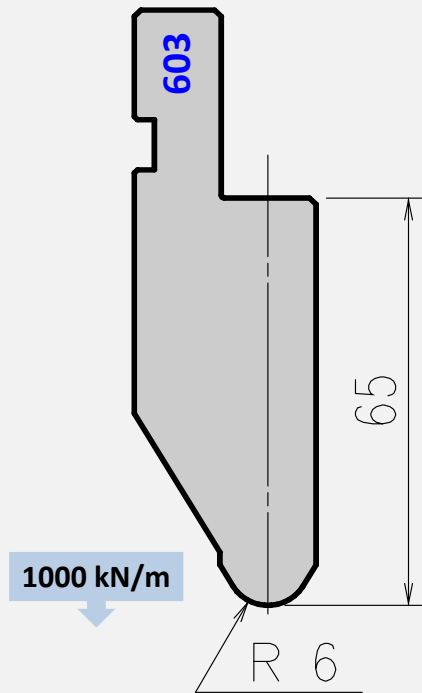

Acute Sash Punch 640

Tool angle	Tip radius	Length mm	Item No.	Weight Kg
60°	R0.8	835	ES6406081	8,3
		415	ES6406082	4,1
		800 Sect	ES6406083	7,6
	R2.0	835	ES6406201	8,3
		415	ES6406202	4,1
		800 Sect	ES6406203	7,6

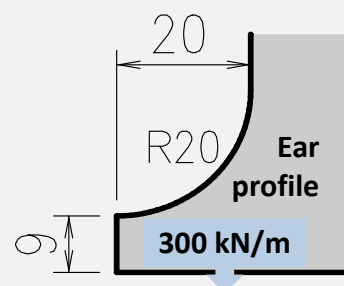
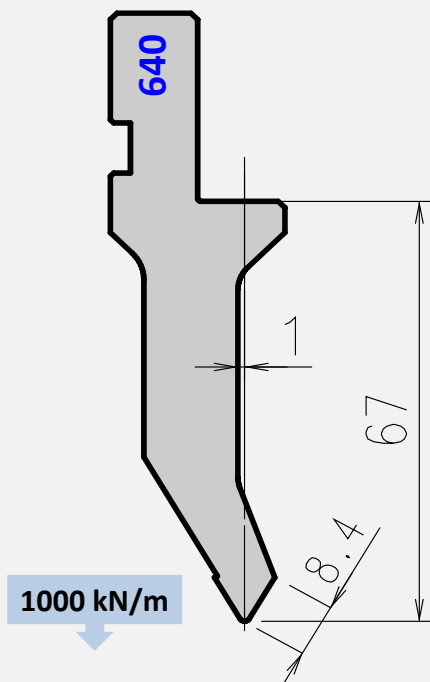

Hemming Punch 631

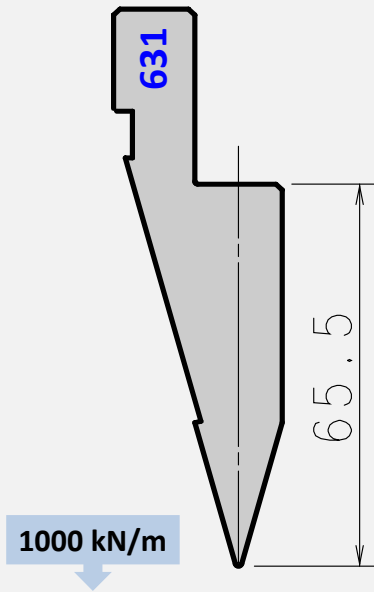

Tool angle	Tip radius	Length mm	Item No.	Weight Kg
30°	R0.52	835	ES6313051	8,4
		415	ES6313052	4,2
		800 Sect	ES6313053	7,7

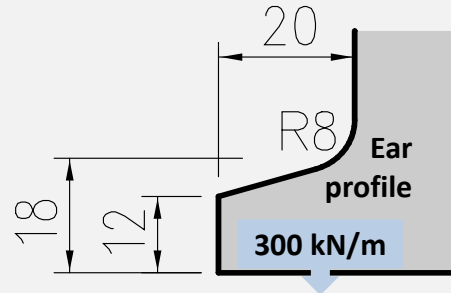

Flattening Punch 622

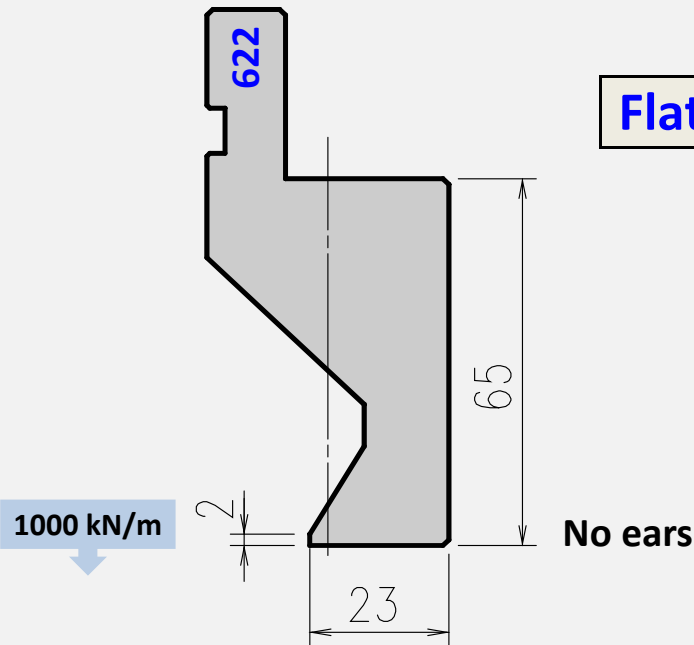

	Length mm	Item No.	Weight Kg
Flattening	835	ES6220001	13,5
	415	ES6220002	6,7

Flattening Punch 020

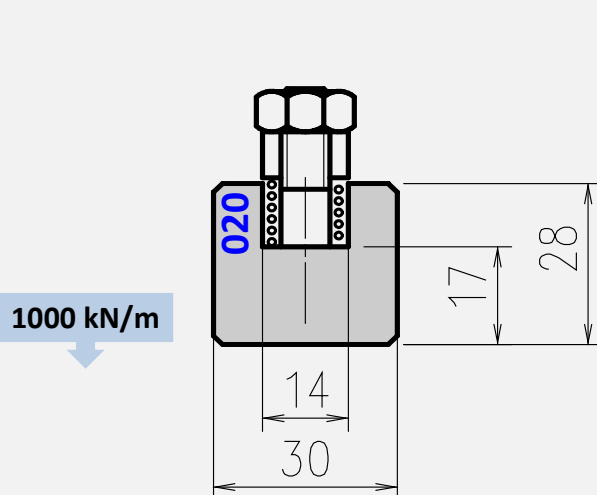

	Length mm	Item No.	Weight Kg
Flattening	835	ES0200001	4,5
	415	ES0200002	2,2

All mounting hardware included.

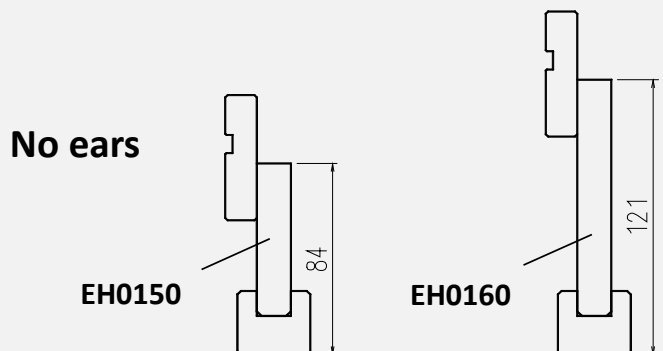

R7 Insert

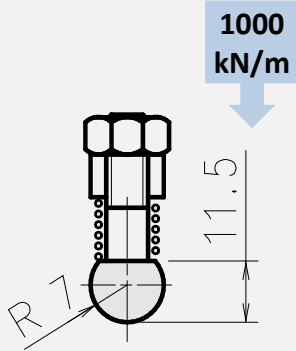

L mm	Item No.	Weight Kg
835	ES0170071	1,0
415	ES0170072	0,6

R8 Insert

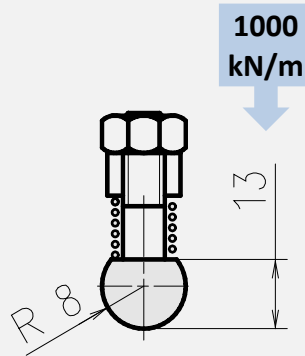

L mm	Item No.	Weight Kg
835	ES0170081	1,5
415	ES0170082	0,8

R9 Insert

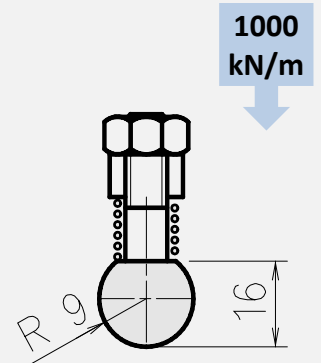

L mm	Item No.	Weight Kg
835	ES0170091	1,9
415	ES0170092	0,9

R10 Insert

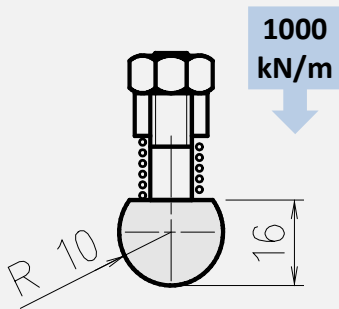

L mm	Item No.	Weight Kg
835	ES0170101	2,1
415	ES0170102	1,1

R11 Insert

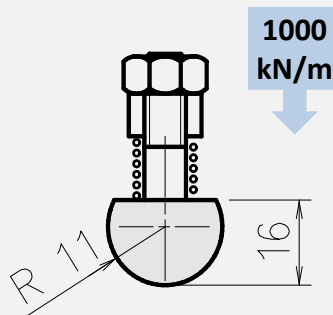

L mm	Item No.	Weight Kg
835	ES0170111	2,3
415	ES0170112	1,2

R12,5 Insert

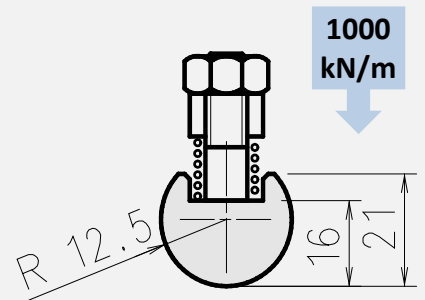

L mm	Item No.	Weight Kg
835	ES0170121	2,7
415	ES0170122	1,4

R14 Insert

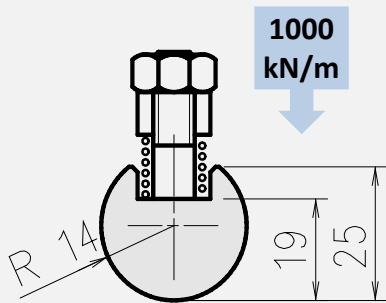

L mm	Item No.	Weight Kg
835	ES0170141	3,6
415	ES0170142	1,8

R15 Insert

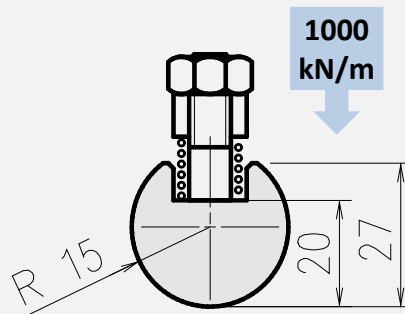

L mm	Item No.	Weight Kg
835	ES0170151	3,7
415	ES0170152	1,8

R16 Insert

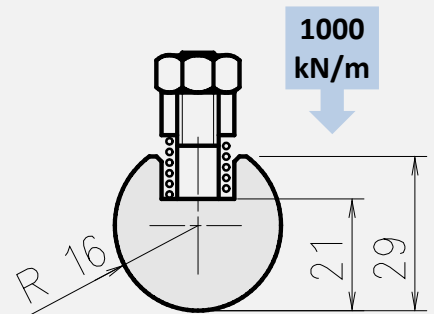

L mm	Item No.	Weight Kg
835	ES0170161	4,6
415	ES0170162	2,3

Note: Use Radius Inserts with Punch Holder EH 0150 or EH 0160. Mounting hardware is included.

R17,5 Insert

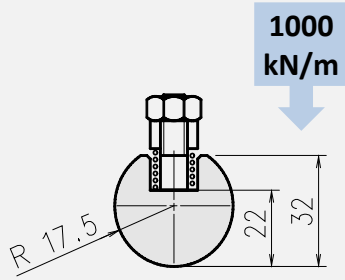

L mm	Item No.	Weight Kg
835	ES0170171	5,1
415	ES0170172	2,5

R20 Insert

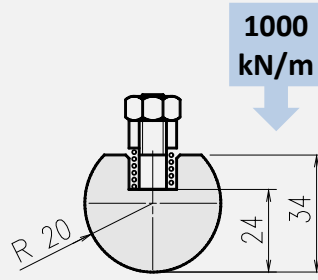

L mm	Item No.	Weight Kg
835	ES0170201	6,5
415	ES0170202	3,2

R22,5 Insert

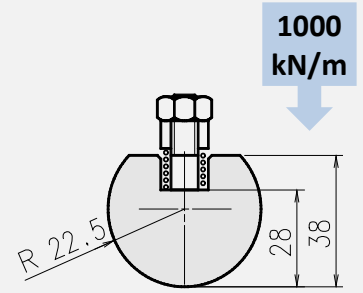

L mm	Item No.	Weight Kg
835	ES0170221	8,8
415	ES0170222	4,4

R25 Insert

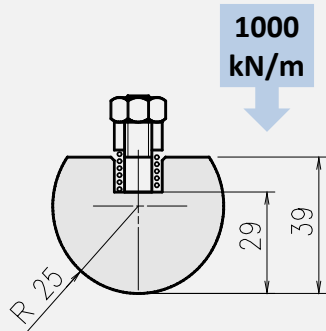

L mm	Item No.	Weight Kg
835	ES0170251	9,8
415	ES0170252	4,8

R30 Insert

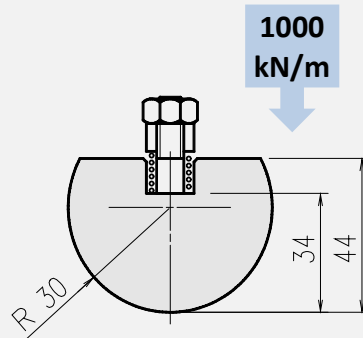

L mm	Item No.	Weight Kg
835	ES0170301	13,6
415	ES0170302	6,8

R35 Insert

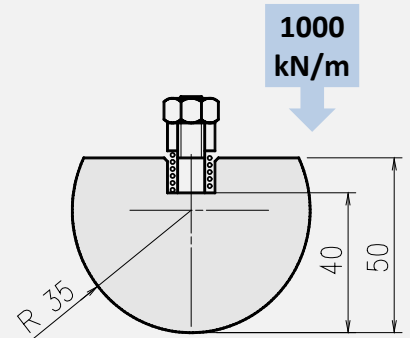

L mm	Item No.	Weight Kg
835	ES0170351	18,5
415	ES0170352	9,2

R40 Insert

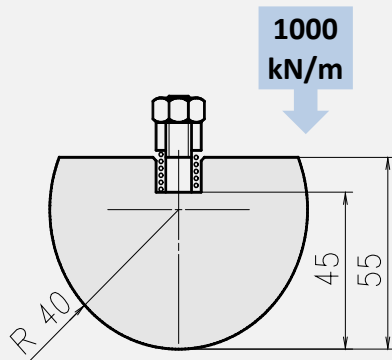

L mm	Item No.	Weight Kg
835	ES0170401	23,3
415	ES0170402	11,6

R45 Insert

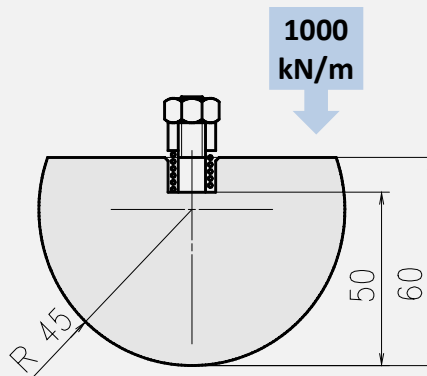

L mm	Item No.	Weight Kg
835	ES0170451	28,7
415	ES0170452	14,3

R50 Insert

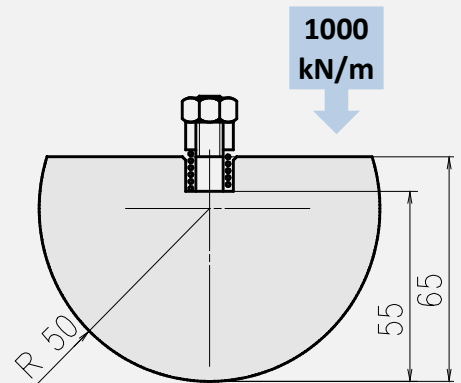

L mm	Item No.	Weight Kg
835	ES0170501	34,6
415	ES0170502	17,2

Note: Use Radius Inserts with Punch Holder EH 0150 or EH 0160. Mounting hardware is included.

Punch Holder : 91

Sect. 835mm = 2x100ear
 20; 25; 30
 35; 40; 50
 70; 165; 200

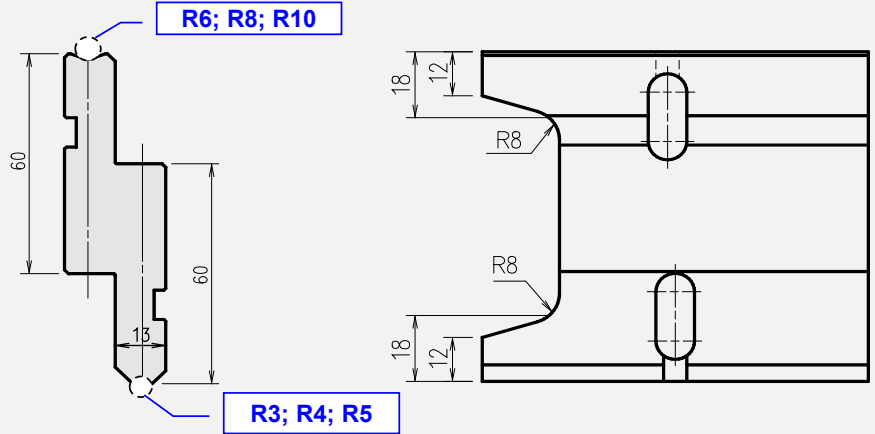
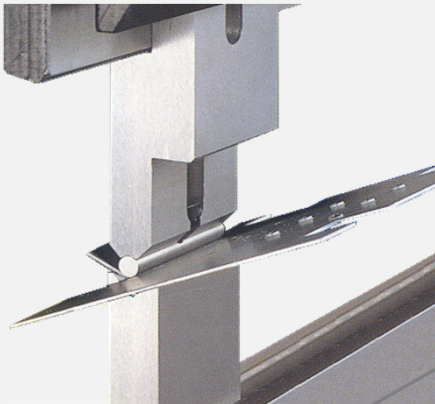

Tonnage:

- 1000 kN/m for 835 and 415 tools
- 150 kN/m for Sect. tools

L mm	Item No.	Weight Kg
835	DX091001	10,0
415	DX091002	5,0
Sect.	DX091801	10,0

R3 Insert

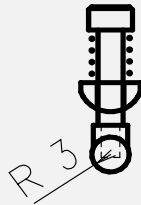

L mm	Item No.	Weight Kg
835	DX090301	0,2
415	DX090302	0,1
Sect.	DX090831	0,2

R4 Insert

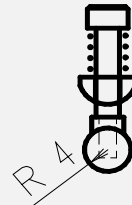

L mm	Item No.	Weight Kg
835	DX090401	0,3
415	DX090402	0,1
Sect.	DX090841	0,3

R5 Insert

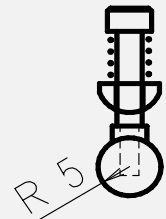

L mm	Item No.	Weight Kg
835	DX090501	0,5
415	DX090502	0,2
Sect.	DX090851	0,5

R6 Insert

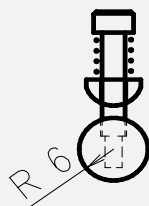

L mm	Item No.	Weight Kg
835	DX090601	0,7
415	DX090602	0,3
Sect.	DX090861	0,7

R8 Insert

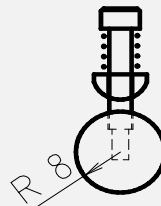

L mm	Item No.	Weight Kg
835	DX090801	1,3
415	DX090802	0,6
Sect.	DX090881	1,3

R10 Insert

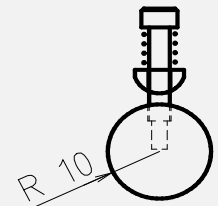

L mm	Item No.	Weight Kg
835	DX090101	2,1
415	DX090102	1,0
Sect.	DX090811	2,1

Colour-Multi-Radius

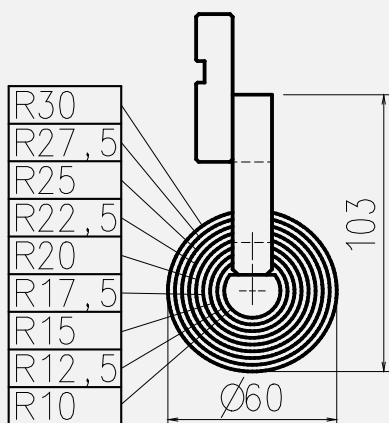

Sect. 835mm =
 25; 40; 50
 100; 120
 200; 300

500 kN/m

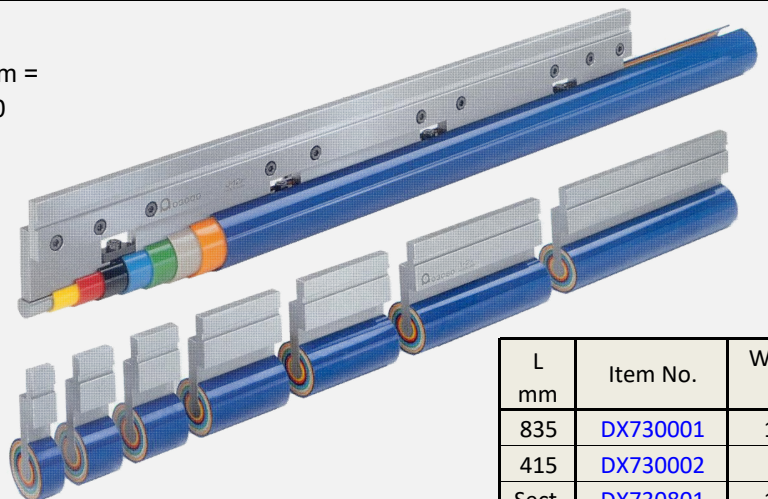

L mm	Item No.	Weight Kg
835	DX730001	13,0
415	DX730002	6,4
Sect.	DX730801	13,0

AFH Standard Die 0703 (V 6)

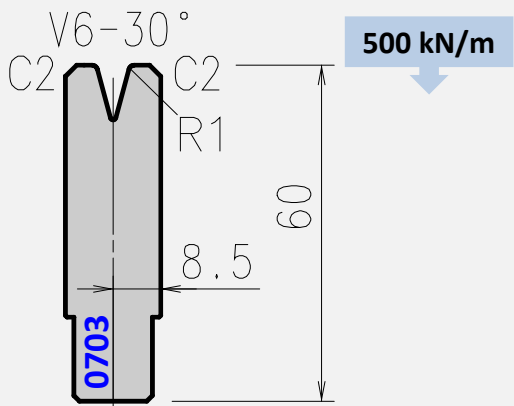

Tool angle	Length mm	Item No.	Weight Kg
30°	835	ED0703101	6,0
	415	ED0703102	3,0
	800 sect.	ED0703103	5,7

Staged* Die 1703 (V 6)

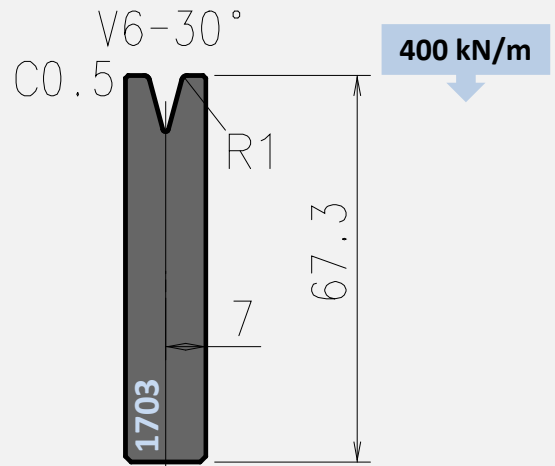

Tool angle	Length mm	Item No.	Weight Kg
30° staged	835	ED1703101	5,9
	415	ED1703102	3,0
	800 sect.	ED1703103	5,7

AFH Standard Die 0713 (V 8)

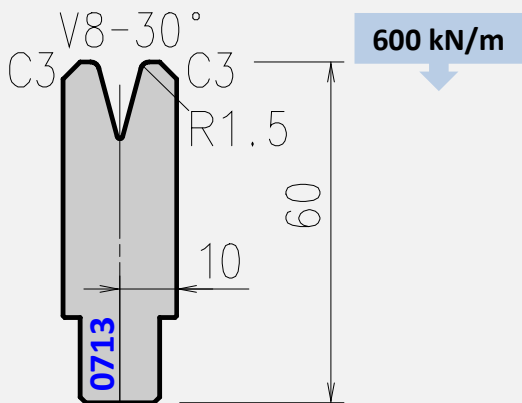

Tool angle	Length mm	Item No.	Weight Kg
30°	835	ED0713151	6,8
	415	ED0713152	3,4
	800 sect.	ED0713153	6,5

Staged* Die 1713 (V 8)

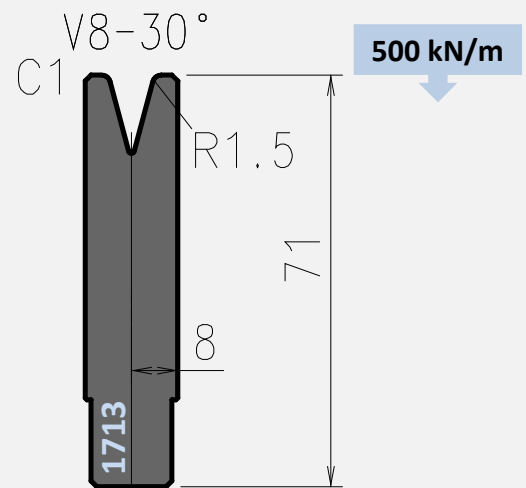

Tool angle	Length mm	Item No.	Weight Kg
30° staged	835	ED1713151	6,8
	415	ED1713152	3,4
	800 sect.	ED1713153	6,5



AFH Standard Die 0723 (V 10)

Staged* Die 1723 (V 10)

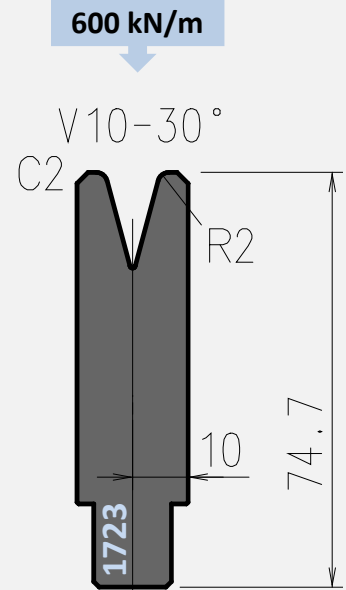
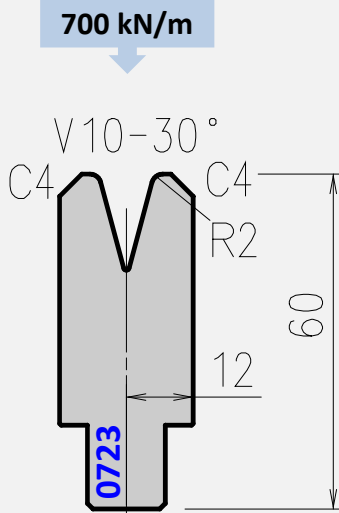

Tool angle	Length mm	Item No.	Weight Kg
30°	835	ED0723201	7,7
	415	ED0723202	3,8
	800 sect.	ED0723203	7,4

Tool angle	Length mm	Item No.	Weight Kg
30° staged	835	ED1723201	8,3
	415	ED1723202	4,2
	800 sect.	ED1723203	8,0

AFH Standard Die 0743 (V 12)

Staged* Die 1743 (V 12)

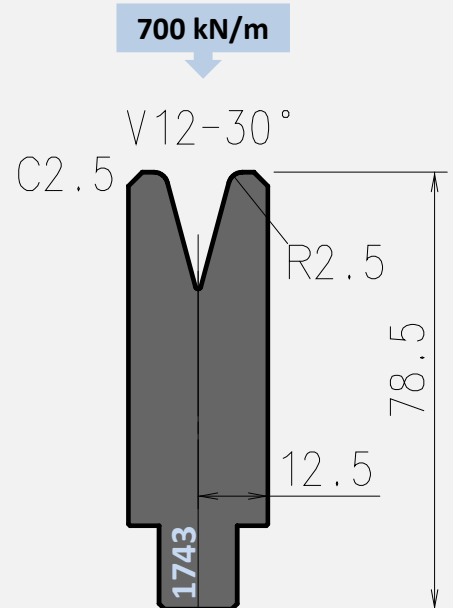
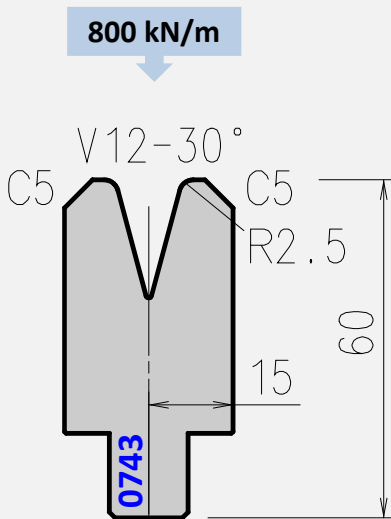

Tool angle	Length mm	Item No.	Weight Kg
30°	835	ED0743251	9,1
	415	ED0743252	4,5
	800 sect.	ED0743253	8,7

Tool angle	Length mm	Item No.	Weight Kg
30° staged	835	ED1743251	10,5
	415	ED1743252	5,2
	800 sect.	ED1743253	10,0

AFH Standard Die 0773 (V 16)

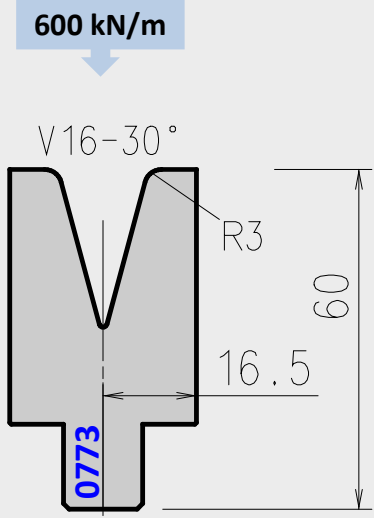

Tool angle	Length mm	Item No.	Weight Kg
30°	835	ED0773301	9,7
	415	ED0773302	4,8
	800 sect.	ED0773303	9,3

Standard Die 0793 (V 20)

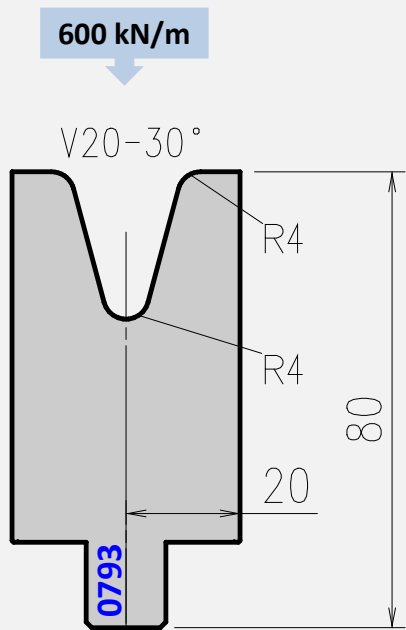

Tool angle	Length mm	Item No.	Weight Kg
30°	835	ED0793401	16,4
	415	ED0793402	8,2
	800 sect.	ED0793403	15,7

Standard Die 0823 (V 25)

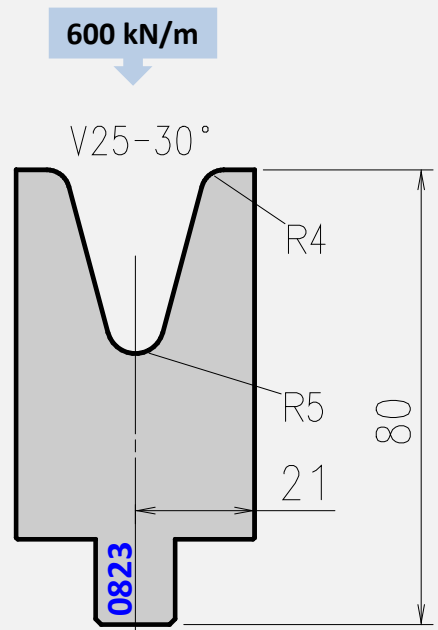

Tool angle	Length mm	Item No.	Weight Kg
30°	835	ED0823401	15,8
	415	ED0823402	7,8
	800 sect.	ED0823403	15,1

Standard Die 0871 (V 32)

Standard Die 0881 (V 40)

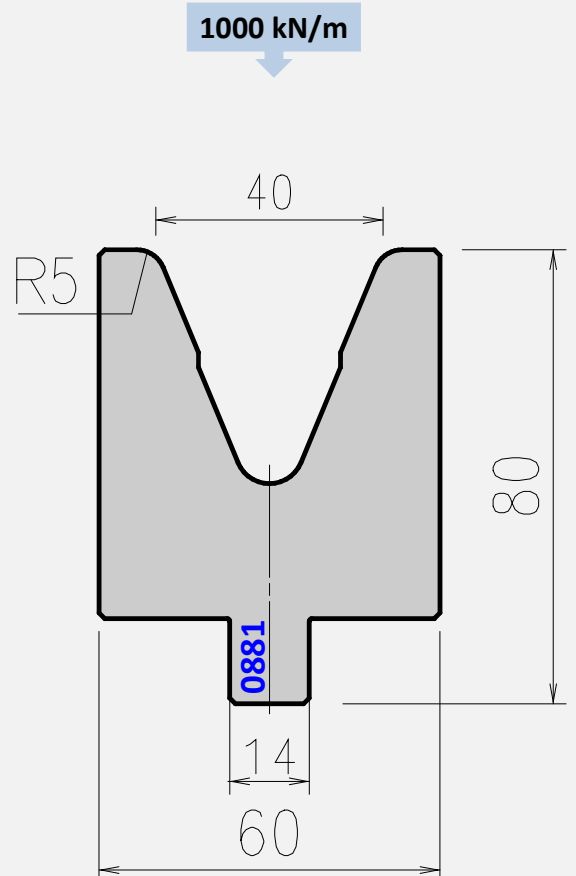
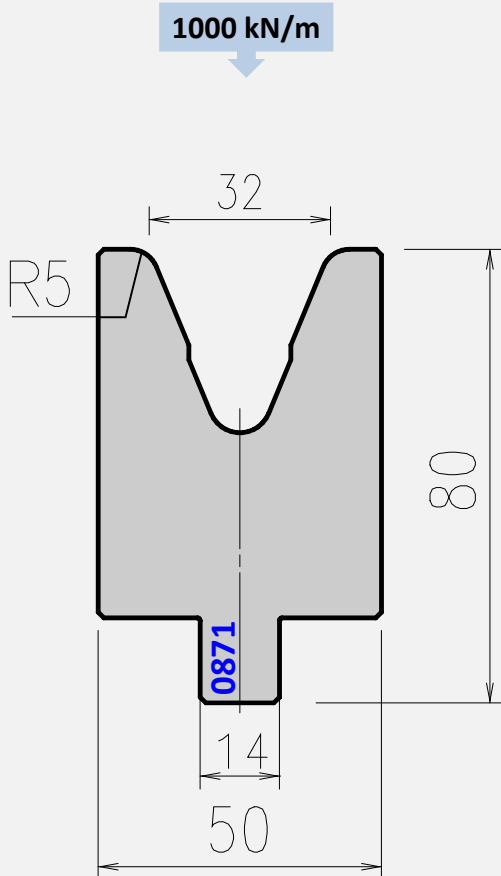

Tool angle	Length mm	Item No.	Weight Kg
45°	835	ED0871501	18,2
	415	ED0871502	9,1
	800 sect.	ED0871503	17,4

Tool angle	Length mm	Item No.	Weight Kg
45°	835	ED0881501	20,1
	415	ED0881502	10,0
	800 sect.	ED0881503	19,3

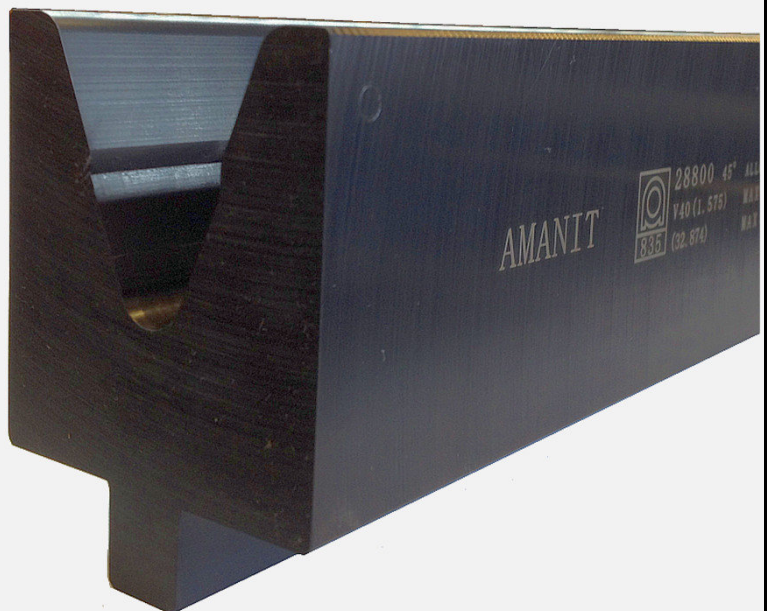
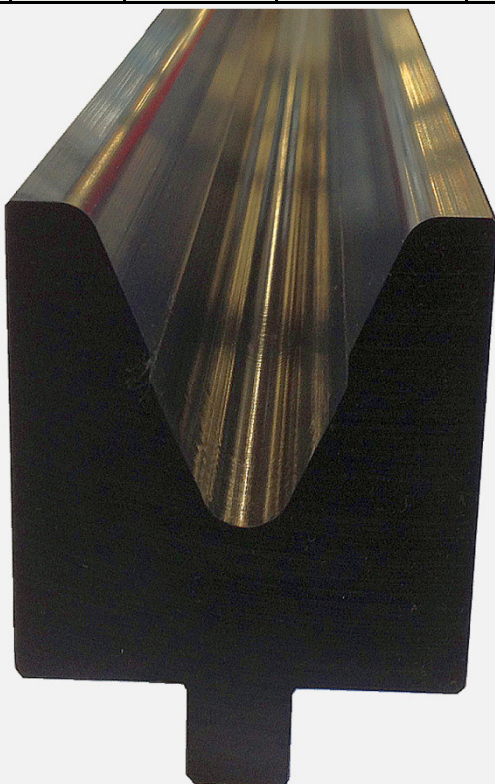

AFH Die 0706 (V 6)

380 kN/m

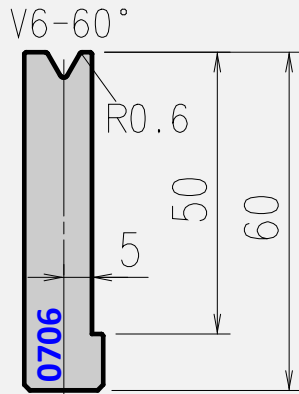

AFH Die 0716 (V 8)

450 kN/m

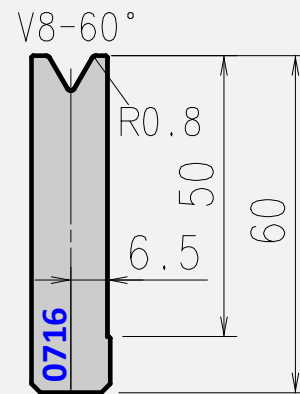

Tool angle	Length mm	Item No.	Weight Kg
60°	835	ED0706061	4,7
	415	ED0706062	2,4
	800 sect.	ED0706063	4,5

Tool angle	Length mm	Item No.	Weight Kg
60°	835	ED0716081	5,1
	415	ED0716082	2,5
	800 sect.	ED0716083	4,9

AFH Die 0726 (V 10)

550 kN/m

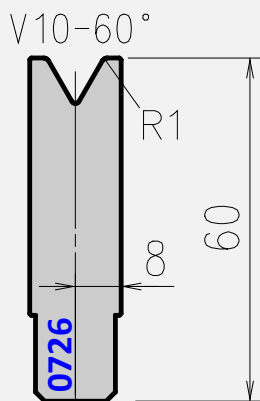

AFH Die 0746 (V 12)

550 kN/m

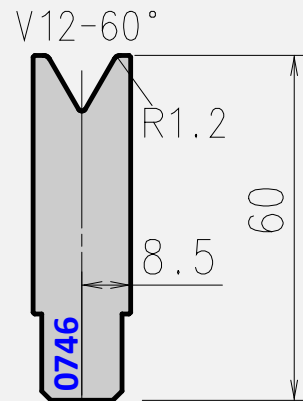

Tool angle	Length mm	Item No.	Weight Kg
60°	835	ED0726101	5,8
	415	ED0726102	2,9
	800 sect.	ED0726103	5,5

Tool angle	Length mm	Item No.	Weight Kg
60°	835	ED0746121	5,9
	415	ED0746122	3,0
	800 sect.	ED0746123	5,7

AFH Die 0776 (V 16)

AFH Die 0796 (V 20)

650 kN/m

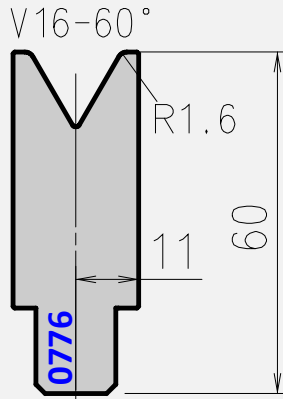

850 kN/m

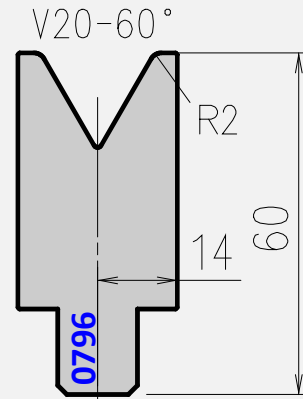

Tool angle	Length mm	Item No.	Weight Kg
60°	835	ED0776161	7,1
	415	ED0776162	3,5
	800 sect.	ED0776163	6,8

Tool angle	Length mm	Item No.	Weight Kg
60°	835	ED0796201	8,4
	415	ED0796202	4,2
	800 sect.	ED0796203	8,1

AFH Die 0826 (V 25)

850 kN/m

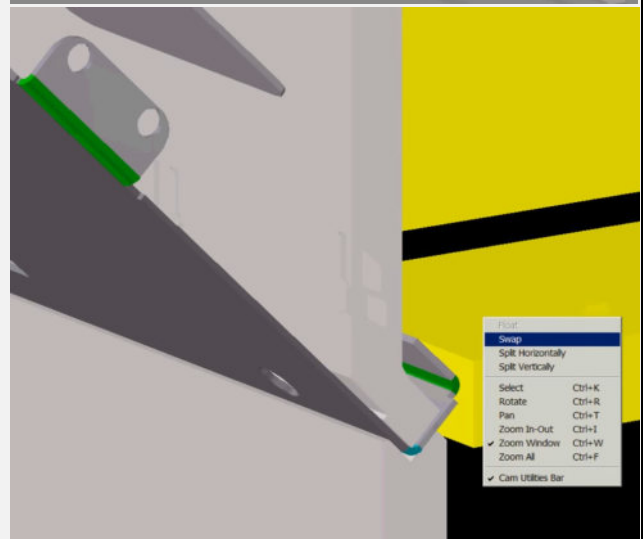
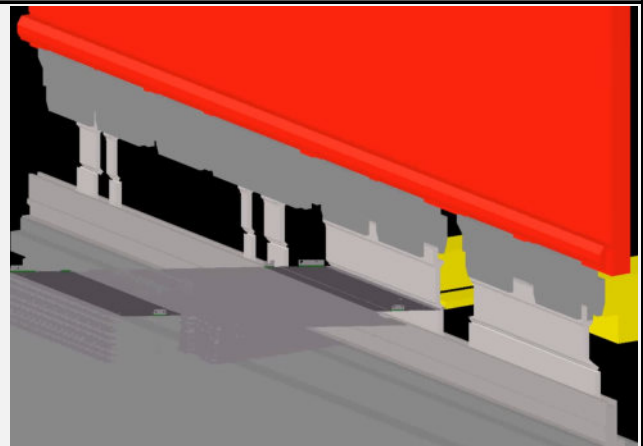
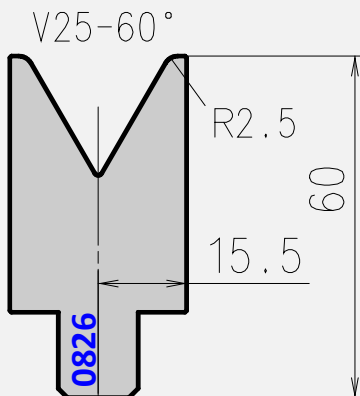

Tool angle	Length mm	Item No.	Weight Kg
60°	835	ED0826251	8,7
	415	ED0826252	4,3
	800 sect.	ED0826253	8,3

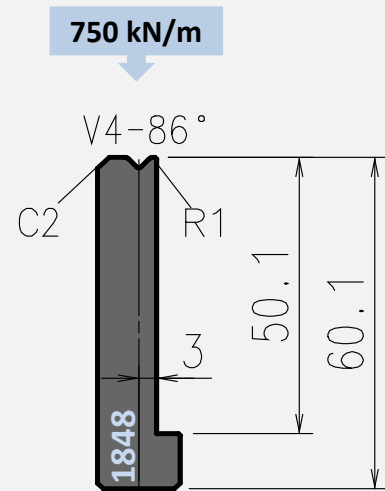
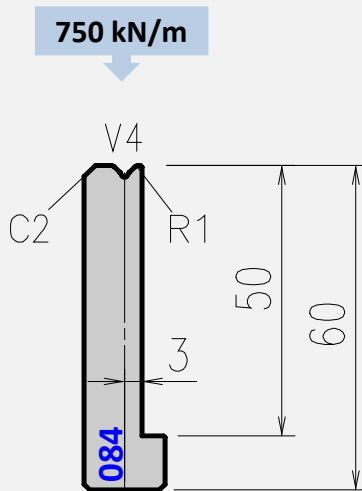
AFH Standard Die 084 (V 4)
Staged* Die 1848 (V 4)

Tool angle	Length mm	Item No.	Weight Kg
86°	835	ED0848101	4,1
	415	ED0848102	2,1
	800 sect.	ED0848103	4,0
88°	835	ED0847101	4,1
	415	ED0847102	2,1
	800 sect.	ED0847103	4,0
90°	835	ED0849101	4,1
	415	ED0849102	2,1
	800 sect.	ED0849103	4,0

Tool angle	Length mm	Item No.	Weight Kg
86° staged	835	ED1848101	4,3
	415	ED1848102	2,2
	800 sect.	ED1848103	4,1

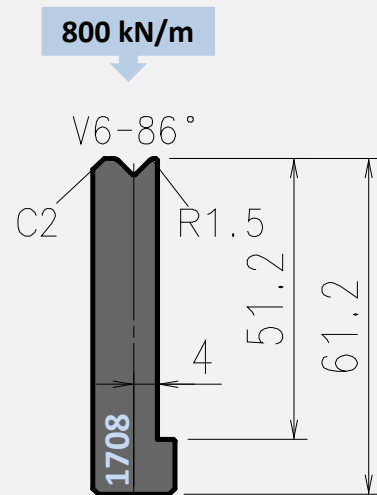
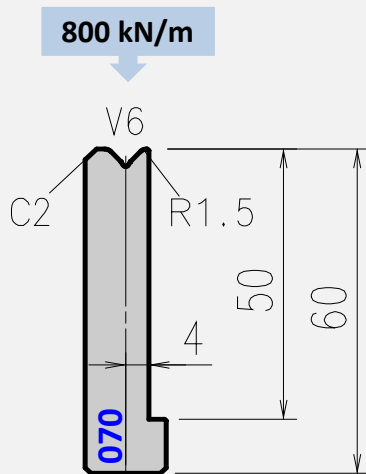
AFH Standard Die 070 (V 6)
Staged* Die 1708 (V 6)

Tool angle	Length mm	Item No.	Weight Kg
86°	835	ED0708151	4,4
	415	ED0708152	2,2
	800 sect.	ED0708153	4,2
88°	835	ED0707151	4,4
	415	ED0707152	2,2
	800 sect.	ED0707153	4,2
90°	835	ED0709151	4,4
	415	ED0709152	2,2
	800 sect.	ED0709153	4,2

Tool angle	Length mm	Item No.	Weight Kg
86° staged	835	ED1708151	4,6
	415	ED1708152	2,3
	800 sect.	ED1708153	4,4

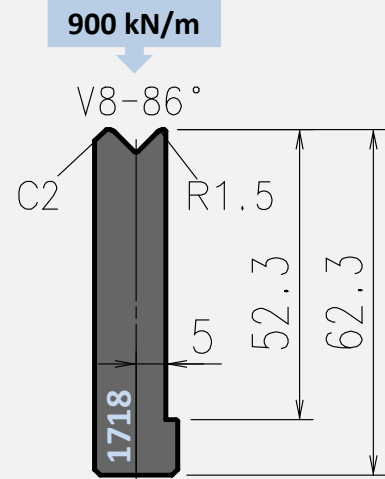
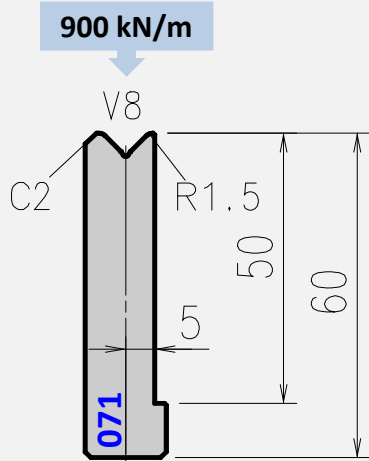
AFH Standard Die 071 (V 8)
Staged* Die 1718 (V 8)

Tool angle	Length mm	Item No.	Weight Kg
86°	835	ED0718151	4,7
	415	ED0718152	2,3
	800 sect.	ED0718153	4,5
88°	835	ED0717151	4,7
	415	ED0717152	2,3
	800 sect.	ED0717153	4,5
90°	835	ED0719151	4,7
	415	ED0719152	2,3
	800 sect.	ED0719153	4,5

Tool angle	Length mm	Item No.	Weight Kg
86° staged	835	ED1718151	4,9
	415	ED1718152	2,5
	800 sect.	ED1718153	4,7

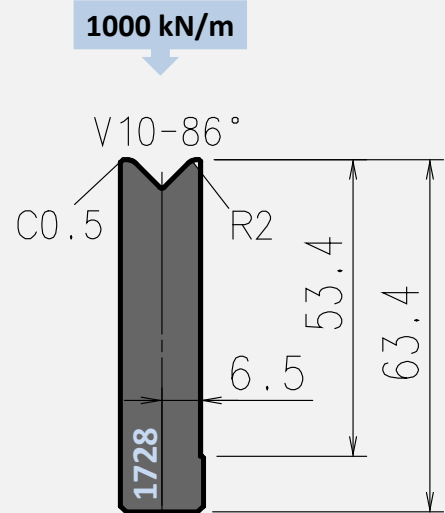
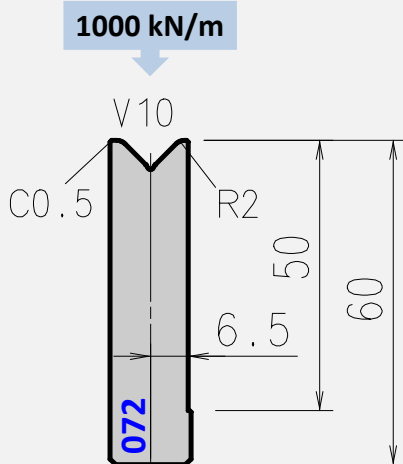
AFH Standard Die 072 (V 10)
Staged* Die 1728 (V 10)

Tool angle	Length mm	Item No.	Weight Kg
86°	835	ED0728201	5,2
	415	ED0728202	2,6
	800 sect.	ED0728203	4,9
88°	835	ED0727201	5,2
	415	ED0727202	2,6
	800 sect.	ED0727203	4,9
90°	835	ED0729201	5,2
	415	ED0729202	2,6
	800 sect.	ED0729203	4,9

Tool angle	Length mm	Item No.	Weight Kg
86° staged	835	ED1728201	5,4
	415	ED1728202	2,7
	800 sect.	ED1728203	5,2

AFH Standard Die 074 (V 12)

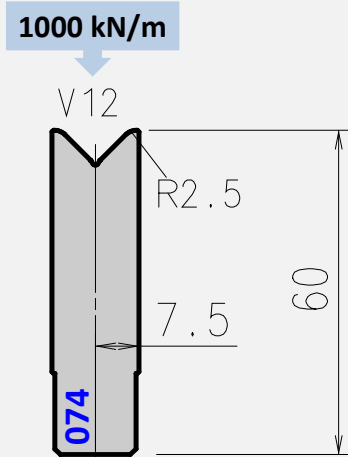

Tool angle	Length mm	Item No.	Weight Kg
86°	835	ED0748251	5,5
	415	ED0748252	2,7
	800 sect.	ED0748253	5,3
88°	835	ED0747251	5,5
	415	ED0747252	2,7
	800 sect.	ED0747253	5,3
90°	835	ED0749251	5,5
	415	ED0749252	2,7
	800 sect.	ED0749253	5,3

Staged* Die 1748 (V 12)

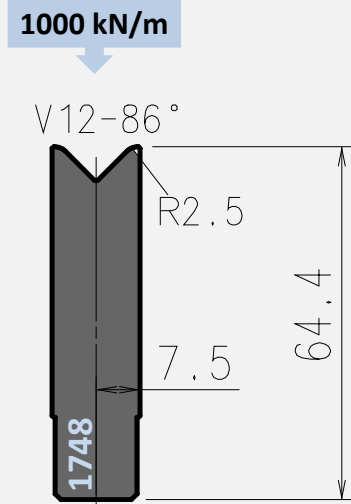

Tool angle	Length mm	Item No.	Weight Kg
86° staged	835	ED1748251	5,8
	415	ED1748252	2,9
	800 sect.	ED1748253	5,6

AFH Standard Die 076 (V 14)

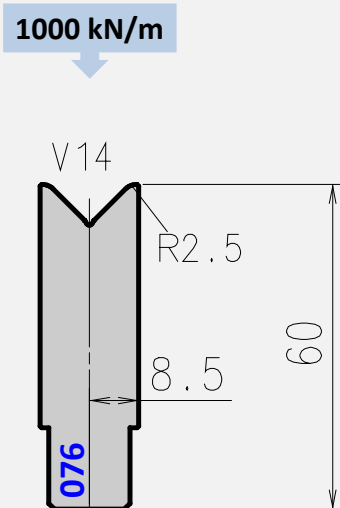

Tool angle	Length mm	Item No.	Weight Kg
86°	835	ED0768251	6,0
	415	ED0768252	3,0
	800 sect.	ED0768253	5,8
88°	835	ED0767251	6,0
	415	ED0767252	3,0
	800 sect.	ED0767253	5,8



AFH Standard Die 077 (V 16)

Staged* Die 1778 (V 16)

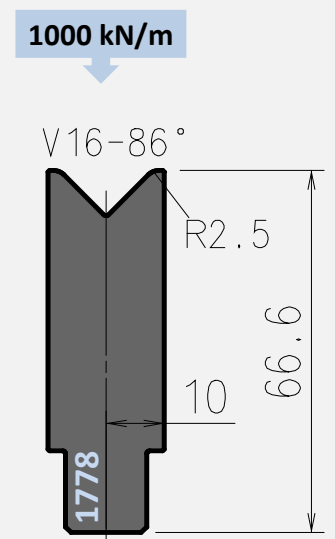
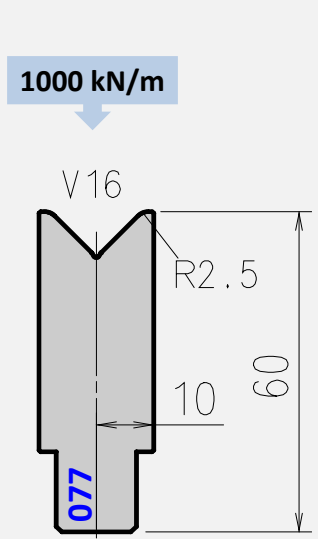

Tool angle	Length mm	Item No.	Weight Kg
86°	835	ED0778251	6,8
	415	ED0778252	3,4
	800 sect.	ED0778253	6,5
88°	835	ED0777251	6,8
	415	ED0777252	3,4
	800 sect.	ED0777253	6,5

Tool angle	Length mm	Item No.	Weight Kg
86° staged	835	ED1778251	7,4
	415	ED1778252	3,7
	800 sect.	ED1778253	7,1

AFH Standard Die 078 (V 18)

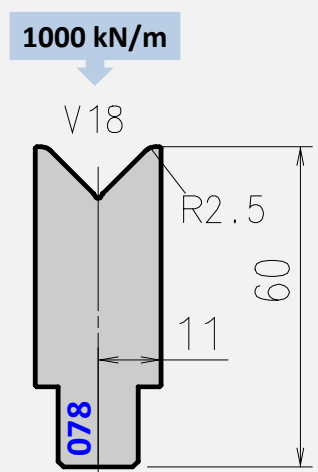

Tool angle	Length mm	Item No.	Weight Kg
86°	835	ED0788251	7,3
	415	ED0788252	3,6
	800 sect.	ED0788253	7,0
88°	835	ED0787251	7,3
	415	ED0787252	3,6
	800 sect.	ED0787253	7,0

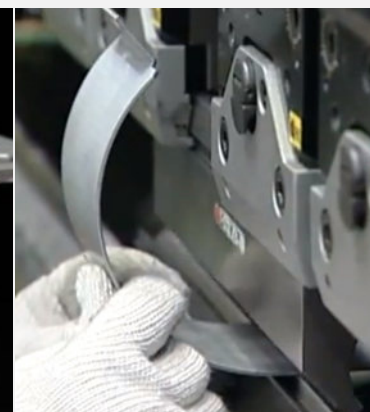
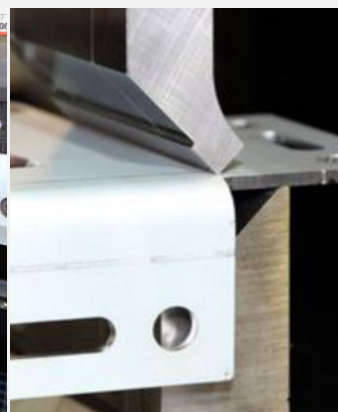

AFH Standard Die 079 (V 20)

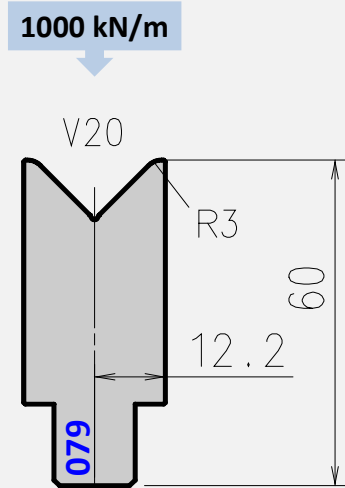

Tool angle	Length mm	Item No.	Weight Kg
86°	835	ED0798301	7,8
	415	ED0798302	3,9
	800 sect.	ED0798303	7,5
88°	835	ED0797301	7,8
	415	ED0797302	3,9
	800 sect.	ED0797303	7,5

Staged* Die 1798 (V 20)

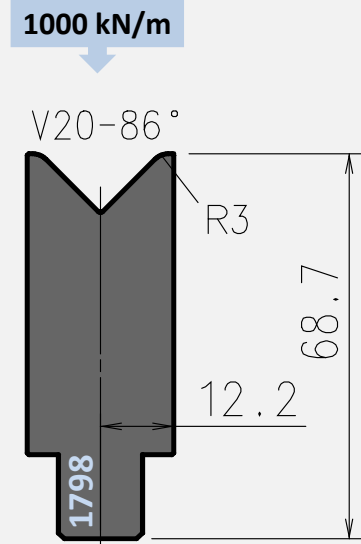

Tool angle	Length mm	Item No.	Weight Kg
86° staged	835	ED1798301	8,9
	415	ED1798302	4,4
	800 sect.	ED1798303	8,5

AFH Standard Die 082 (V 25)

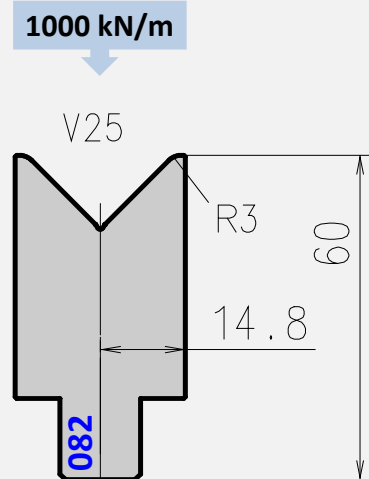

Tool angle	Length mm	Item No.	Weight Kg
86°	835	ED0828301	9,0
	415	ED0828302	4,5
	800 sect.	ED0828303	8,6
88°	835	ED0827301	9,0
	415	ED0827302	4,5
	800 sect.	ED0827303	8,6

Staged* Die 1828 (V 25)

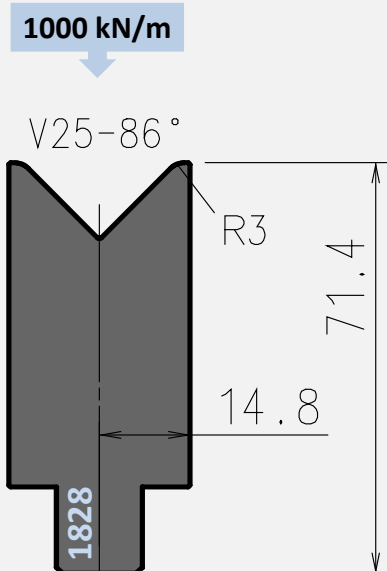

Tool angle	Length mm	Item No.	Weight Kg
86° staged	835	ED1828301	10,6
	415	ED1828302	5,3
	800 sect.	ED1828303	10,2

AFH Standard Die 0874 (V 32)

AFH Standard Die 0884 (V 40)

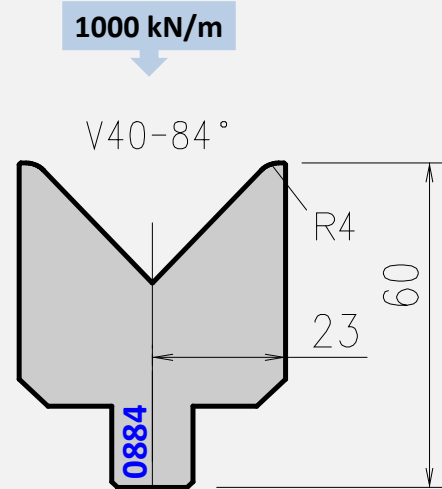
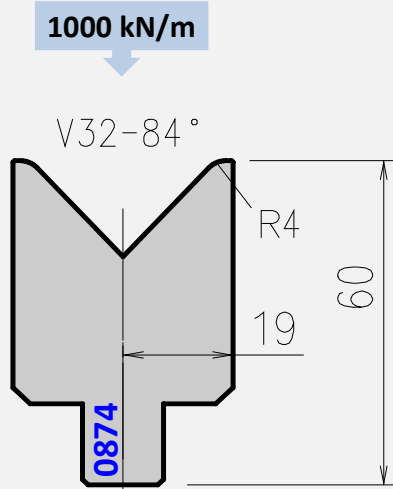

Tool angle	Length mm	Item No.	Weight Kg
84°	835	ED0874401	10,6
	415	ED0874402	5,3
	800 sect.	ED0874403	10,2

Tool angle	Length mm	Item No.	Weight Kg
84°	835	ED0884401	11,8
	415	ED0884402	5,9
	800 sect.	ED0884403	11,3

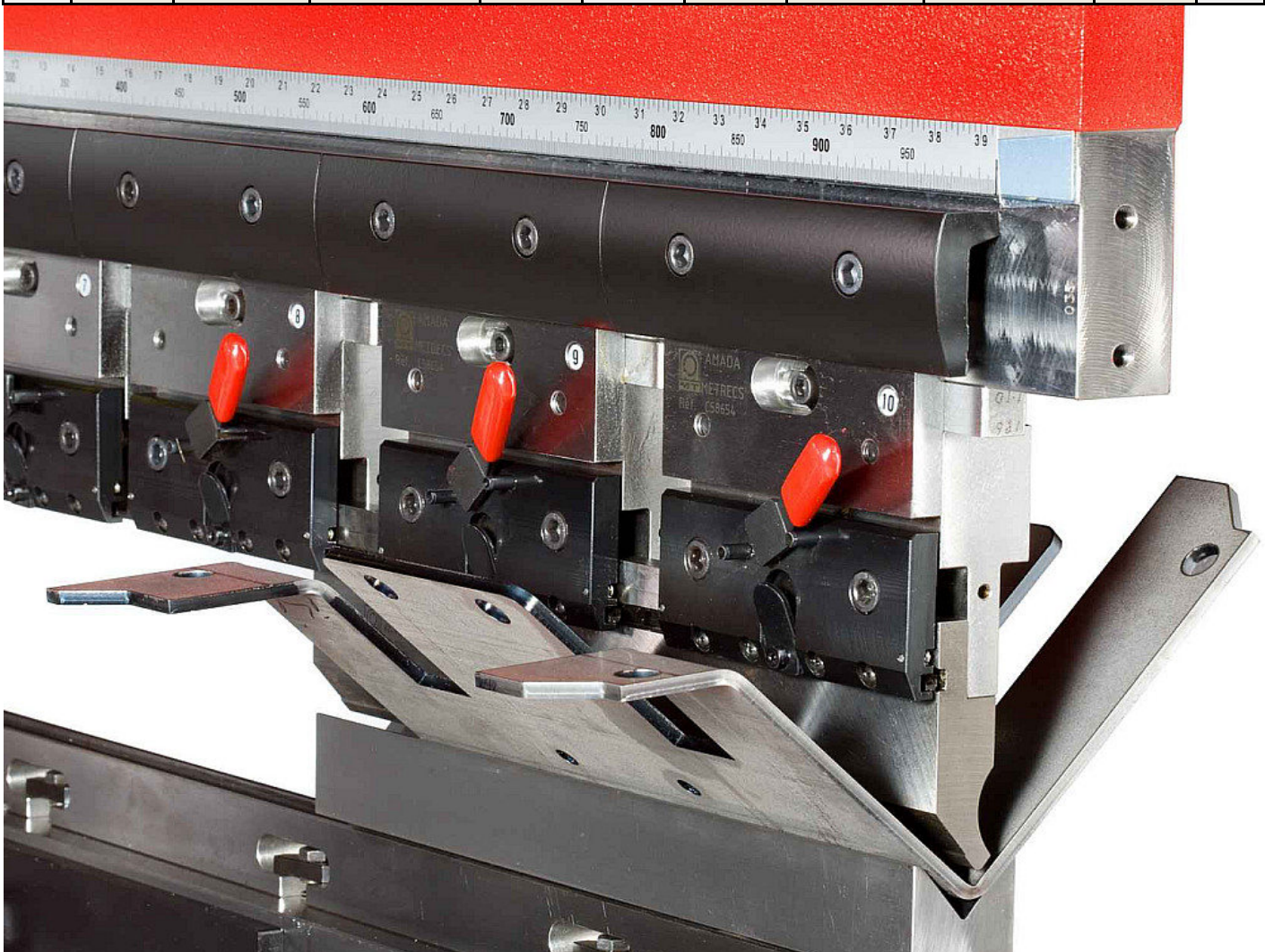

Staged Punch Holder 0282 (to use with H90 mm punches)

Staged Punch Holder 0582 (to use with H120 mm punches)

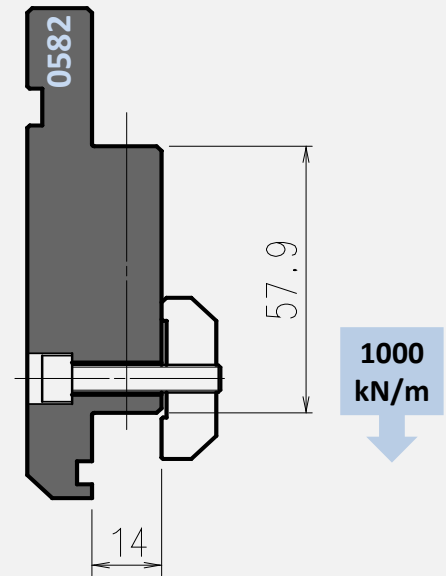
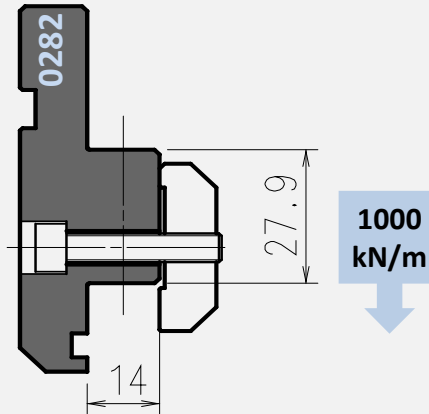

Length mm	Item No.	Weight Kg
415	EH0282002	5,3

Length mm	Item No.	Weight Kg
415	EH0582002	7,9

Staged Hemming Tool 1600

1000 kN/m

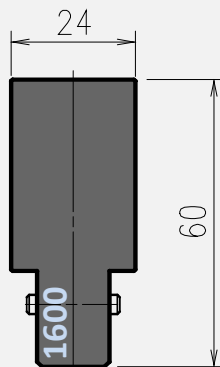

Notes:

1. Staged hemming tool is reversible and can be mounted on punch or die holder. Depending on thrust force direction tool stops are needed on punch side or on die side.
2. Flattening involves high thrust forces, therefore it's sequence always needs an intermittent stroke.

Length mm	Item No.	Weight Kg
835	ED1600001	8,0
415	ED1600002	4,0
800 sect.	ED1600003	7,7

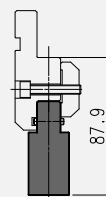

Hemming punch H90

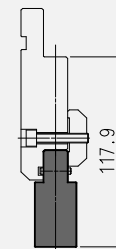

Hemming punch H120

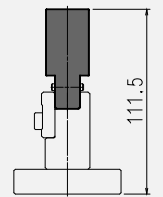

Hemming die

Tool Stop for flattening

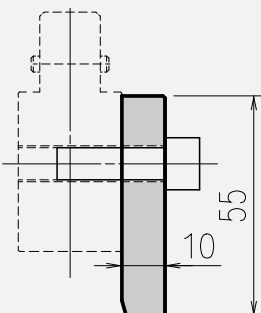

Note:

Tool stop prevents thrust forces from affecting the rest of tooling system.

Length mm	Item No.	Weight Kg
for 835	ED1600011	3,7
for 415	ED1600012	1,8
for sect.	ED1600013	3,5

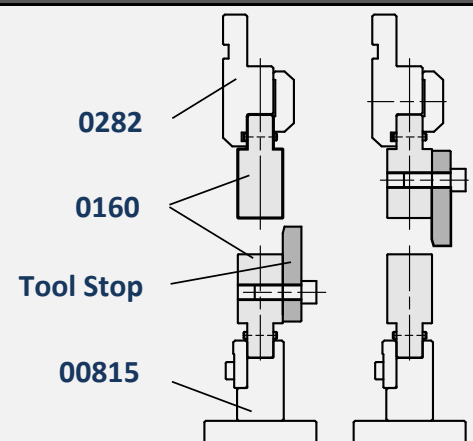

Staged Offset Tool Z3
Staged Offset Tool Z4
Staged Offset Tool Z5

1000 kN/m

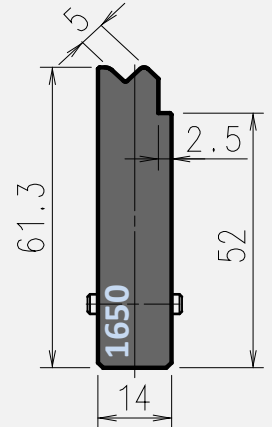
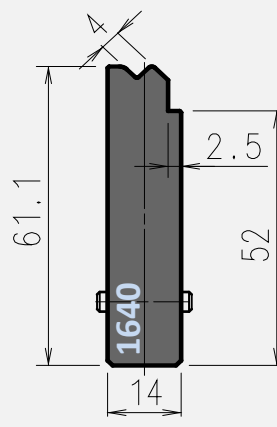
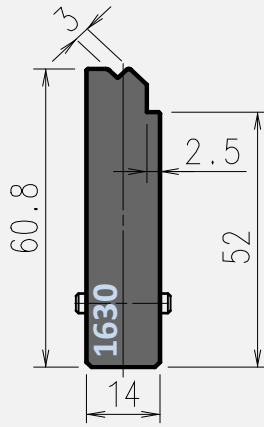

Length mm	Item No.	Weight Kg
835	ED1630061	5,4
415	ED1630062	2,7
800 sect.	ED1630063	5,2

Item No.	Weight Kg
ED1640081	5,4
ED1640082	2,7
ED1640083	5,2

Item No.	Weight Kg
ED1650101	5,4
ED1650102	2,7
ED1650103	5,2

Staged Offset Tool Z6
Staged Offset Tool Z8
Staged Offset Tool Z10

1000 kN/m

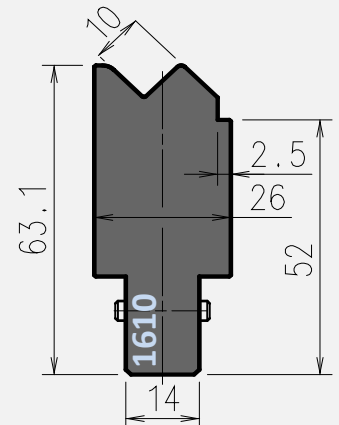
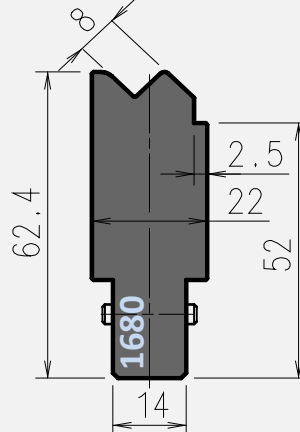
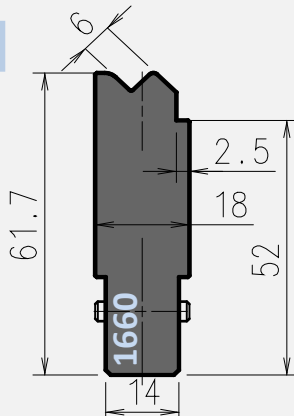

Length mm	Item No.	Weight Kg
835	ED1660101	6,4
415	ED1660102	3,2
800 sect.	ED1660103	6,1

Item No.	Weight Kg
ED1680101	7,5
ED1680102	3,7
ED1680103	7,2

Item No.	Weight Kg
ED1610101	8,6
ED1610102	4,3
ED1610103	8,2

Note:

- Staged offset tools are reversible and can be mounted on a punch or die holder
- Use with holder 0282 for H=90mm and with 0582 for H=120mm punch height
- Two of each code are required when ordering a punch and die set

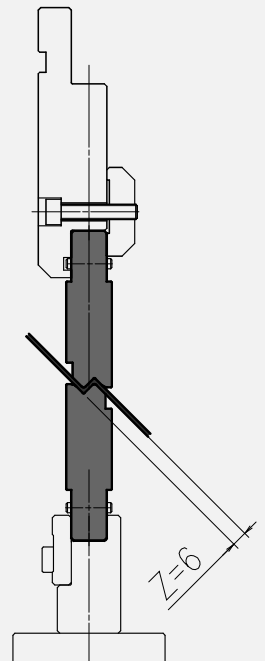
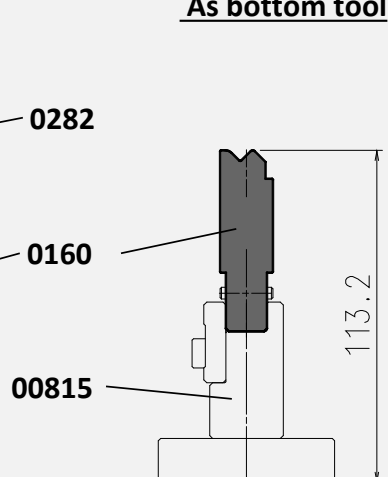
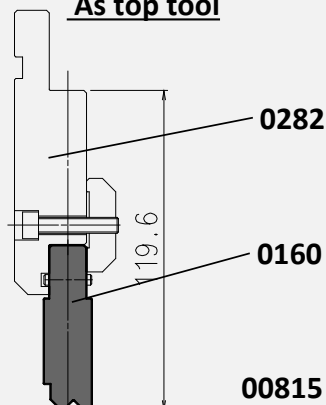
As top tool
As bottom tool

90° 2V dies (V4 to V9)

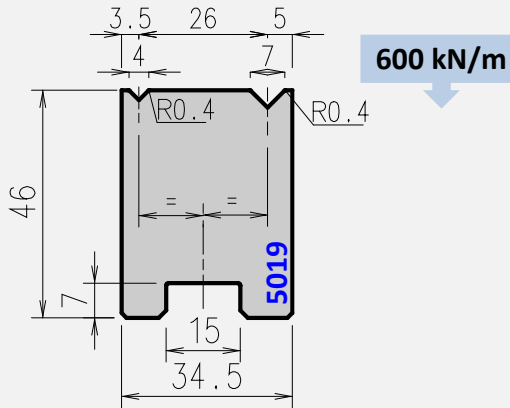

Tool angle	Length mm	Item No.	Weight Kg
90°	835	ED5019041	9,6
	415	ED5019042	4,8
	800 sect.	ED5019043	9,2

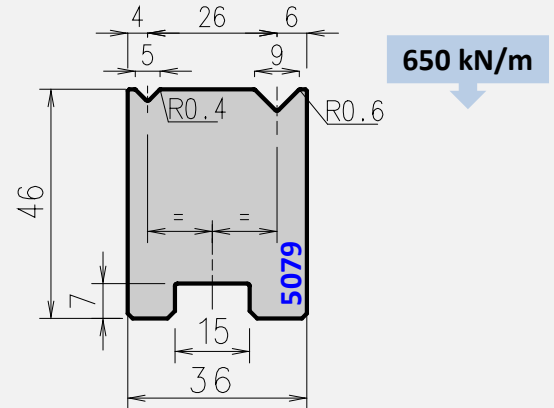

Tool angle	Length mm	Item No.	Weight Kg
90°	835	ED5079041	10,0
	415	ED5079042	5,0
	800 sect.	ED5079043	9,6

90° 2V dies (V6 to V12)

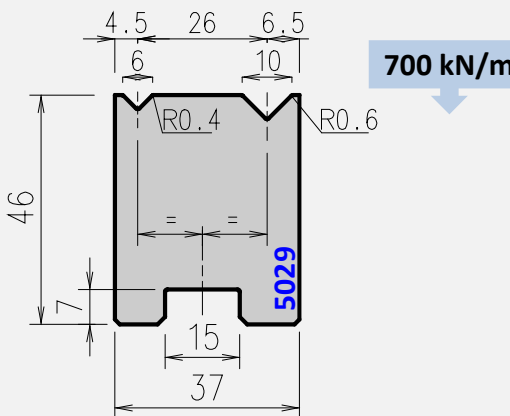

Tool angle	Length mm	Item No.	Weight Kg
90°	835	ED5029041	10,3
	415	ED5029042	5,1
	800 sect.	ED5029043	9,9

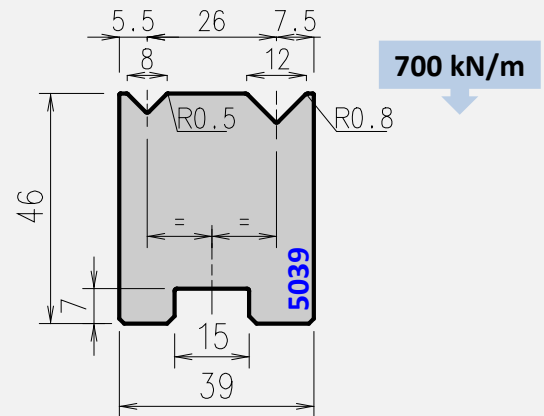

Tool angle	Length mm	Item No.	Weight Kg
90°	835	ED5039051	10,7
	415	ED5039052	5,3
	800 sect.	ED5039053	10,3

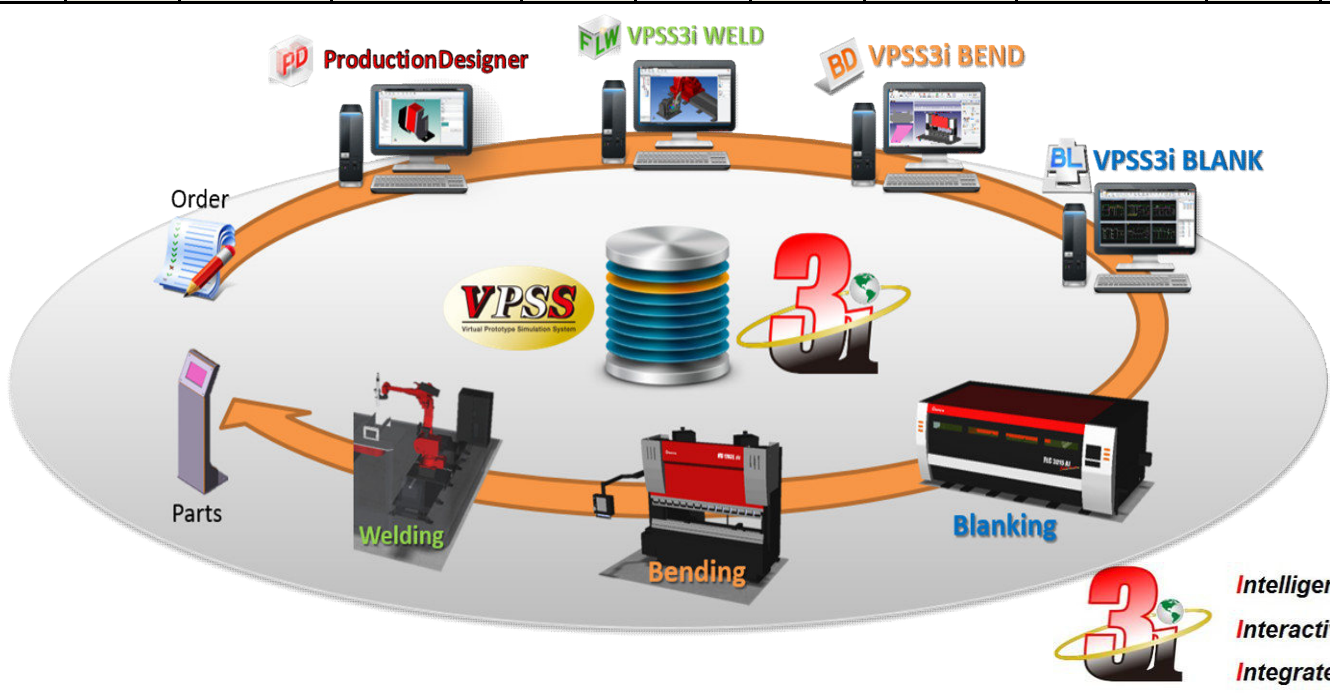

88° 2V dies (V4 to V10)

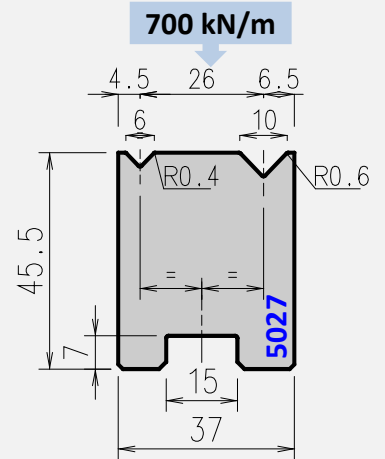
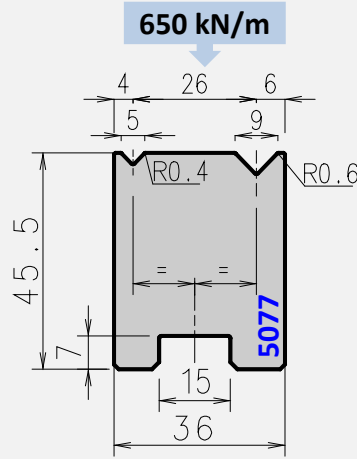
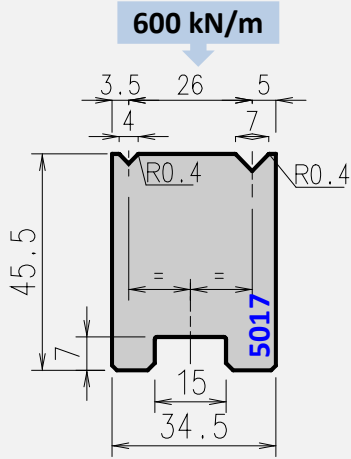

Tool angle	Length mm	Item No.	Weight Kg
88°	835	ED5017041	9,5
	415	ED5017042	4,7
	800 sect.	ED5017043	9,1

Item No.	Weight Kg
ED5077041	9,9
ED5077042	4,9
ED5077043	9,5

Item No.	Weight Kg
ED5027041	10,2
ED5027042	5,1
ED5027043	9,8

88° 2V dies (V8 to V20)

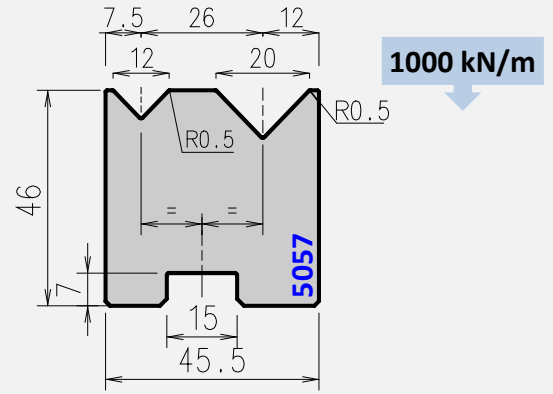
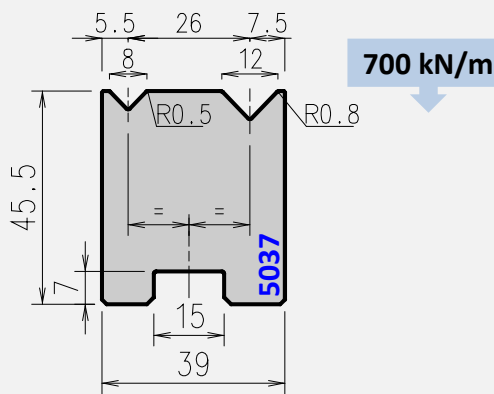

Tool angle	Length mm	Item No.	Weight Kg
88°	835	ED5037051	10,6
	415	ED5037052	5,3
	800 sect.	ED5037053	10,2

Tool angle	Length mm	Item No.	Weight Kg
88°	835	ED5057051	12,1
	415	ED5057052	6,0
	800 sect.	ED5057053	11,6

88° 2V dies (V14 to V25)

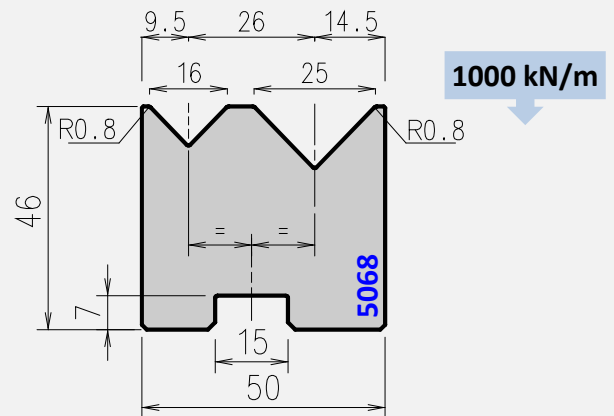
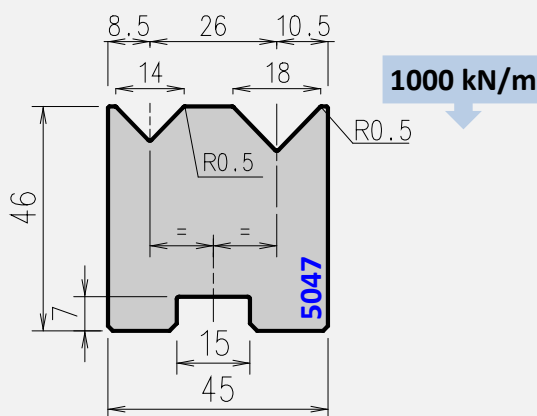

Tool angle	Length mm	Item No.	Weight Kg
88°	835	ED5047051	12,0
	415	ED5047052	6,0
	800 sect.	ED5047053	11,5

Tool angle	Length mm	Item No.	Weight Kg
88°	835	ED5067081	12,9
	415	ED5067082	6,4
	800 sect.	ED5067083	12,4

30° - 2V dies (V6 to V12)

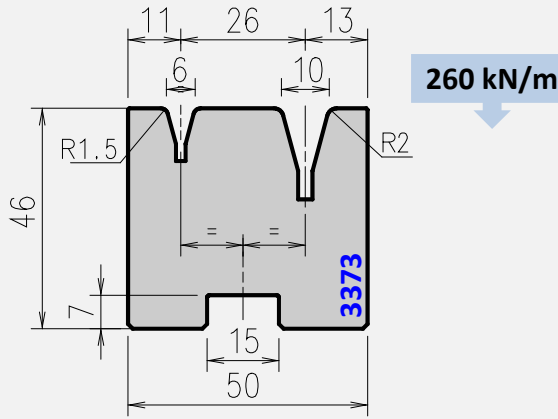

Tool angle	Length mm	Item No.	Weight Kg
30°	835	ED3373151	13,5
	415	ED3373152	6,7
	800 sect.	ED3373153	12,9

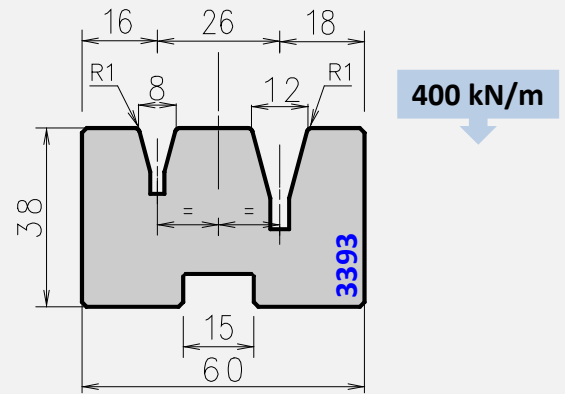

Tool angle	Length mm	Item No.	Weight Kg
30°	835	ED3393101	12,9
	415	ED3393102	6,4
	800 sect.	ED3393103	12,4

60° - 2V dies (V6 to V12)

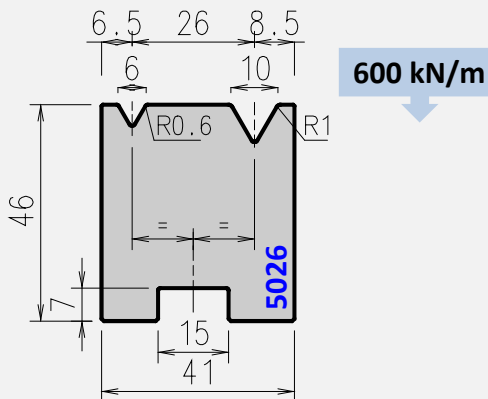

Tool angle	Length mm	Item No.	Weight Kg
60°	835	ED5026061	11,3
	415	ED5026062	5,6
	800 sect.	ED5026063	10,8

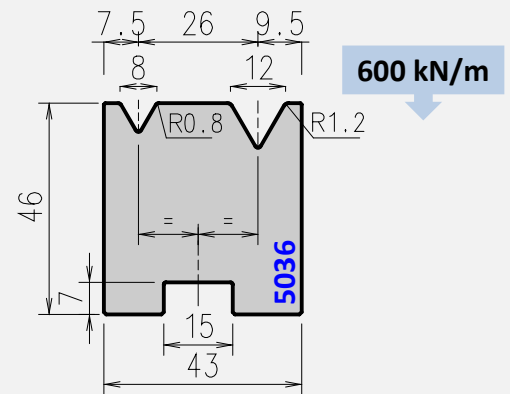

Tool angle	Length mm	Item No.	Weight Kg
60°	835	ED5036081	11,7
	415	ED5036082	5,8
	800 sect.	ED5036083	11,2

60° - 2V dies (V16 to V25)

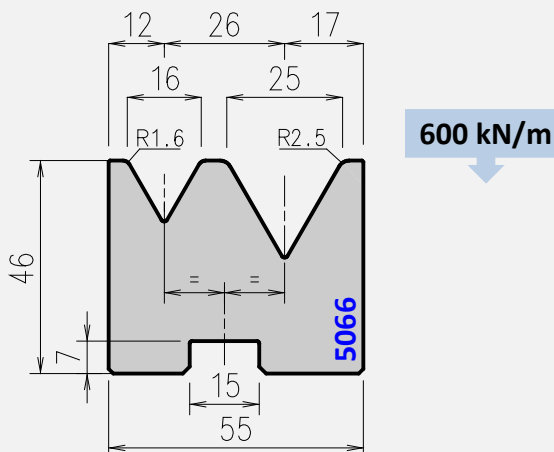

Tool angle	Length mm	Item No.	Weight Kg
60°	835	ED5066161	13,4
	415	ED5066162	6,7
	800 sect.	ED5066163	12,8



V18 and V25 - 30° Large V dies

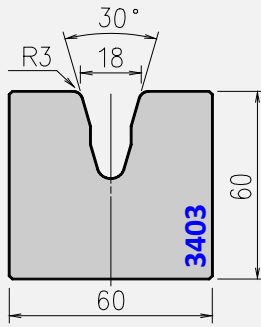

1000
kN/m

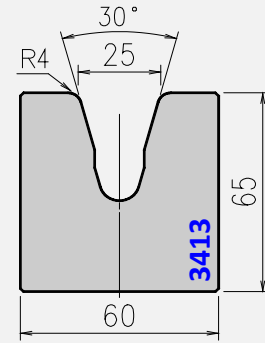

1000
kN/m

Tool angle	Length mm	Item No.	Weight Kg
30°	835	ED3403301	21,4
	415	ED3403302	10,6
	800 sect.	ED3403303	20,5

Tool angle	Length mm	Item No.	Weight Kg
30°	835	ED3413401	21,7
	415	ED3413402	10,8
	800 sect.	ED3413403	20,8

V32 and V40 - 45° Large V dies

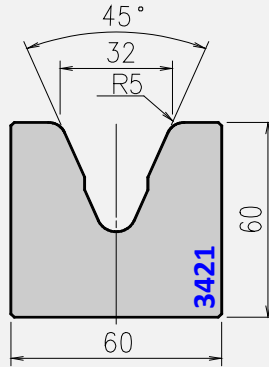

1000
kN/m

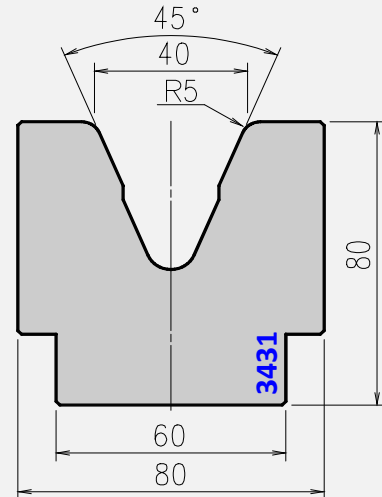

700
kN/m

Hardness:
52-56 HRC
inductionhard.
Depth: 2mm

Tool angle	Length mm	Item No.	Weight Kg
45°	835	ED3421501	19,3
	415	ED3421502	9,6
	800 sect.	ED3421503	18,5

Tool angle	Length mm	Item No.	Weight Kg
45°	835	ED3431501	32,6
	415	ED3431502	16,2
	800 sect.	ED3431503	31,2

V63 and V80 - 60° Large V dies

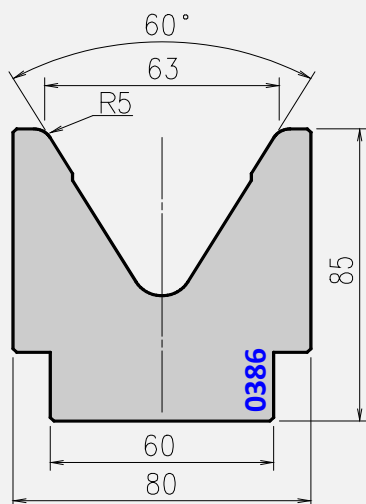

1000
kN/m

Hardness:
52-56 HRC
inductionhard.
Depth: 2mm

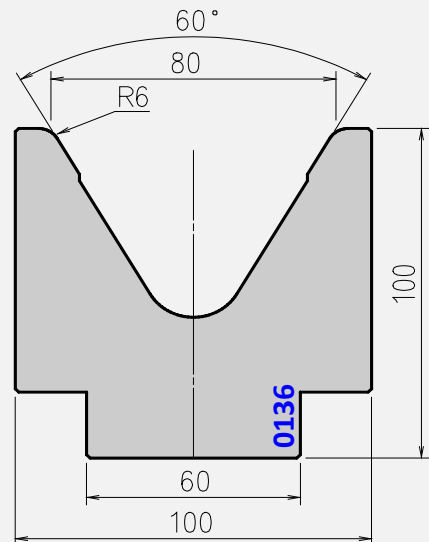

1000
kN/m

Hardness:
52-56 HRC
inductionhard.
Depth: 2mm

Tool angle	Length mm	Item No.	Weight Kg
60°	835	ED0386501	30,2
	415	ED0386502	15,0

Tool angle	Length mm	Item No.	Weight Kg
60°	835	ED0136601	42,0
	415	ED0136602	20,9

V32 and V40 - 85° Large V dies

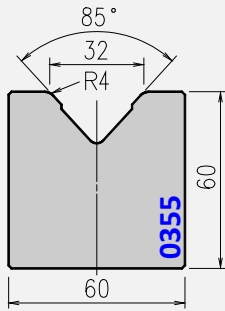

1000 kN/m

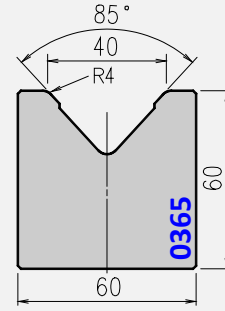

1000 kN/m

Tool angle	Length mm	Item No.	Weight Kg
85°	835	ED0355401	21,4
	415	ED0355402	10,7
	800 sect.	ED0355403	20,5

Tool angle	Length mm	Item No.	Weight Kg
85°	835	ED0365401	20,2
	415	ED0365402	10,1
	800 sect.	ED0365403	19,4

V50 and V63 - 85° Large V dies

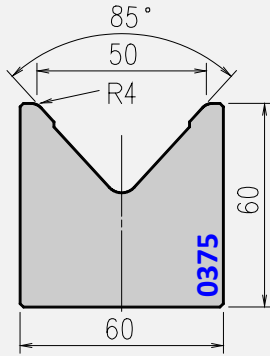

1000 kN/m

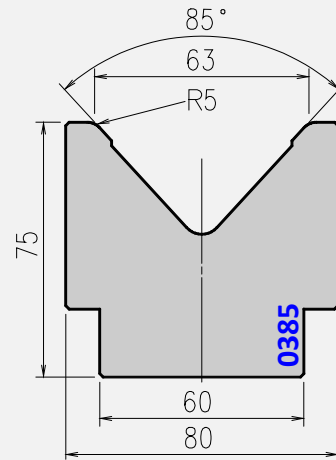

1000 kN/m

 Hardness:
52-56 HRC
inductionhard.
Depth: 2mm

Tool angle	Length mm	Item No.	Weight Kg
85°	835	ED0375401	18,7
	415	ED0375402	9,3
	800 sect.	ED0375403	17,9

Tool angle	Length mm	Item No.	Weight Kg
85°	835	ED0385501	29,1
	415	ED0385502	14,4
	800 sect.	ED0385503	27,8

V80 - 85° and V100 - 80° Large V dies

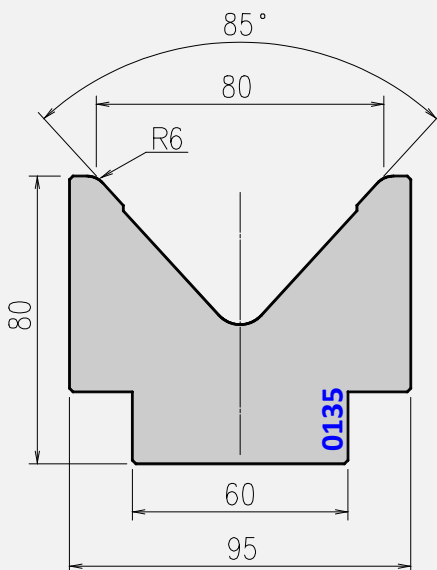

1000 kN/m

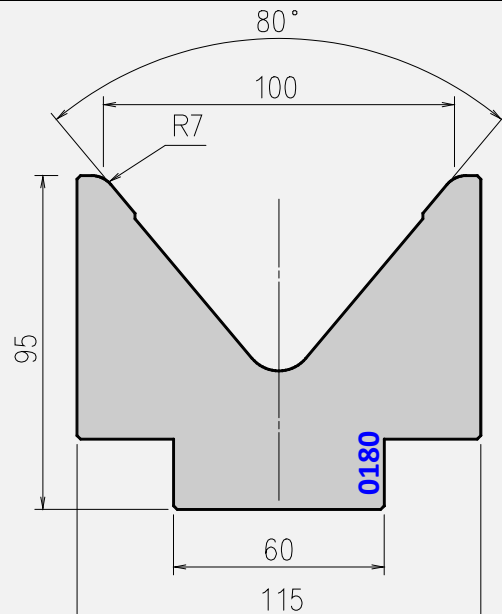
 Hardness:
52-56 HRC
inductionhard.
Depth: 2mm

1000 kN/m

 Hardness:
52-56 HRC
inductionhard.
Depth: 2mm

Tool angle	Length mm	Item No.	Weight Kg
85°	835	ED0135601	33,2
	415	ED0135602	16,5

Tool angle	Length mm	Item No.	Weight Kg
80°	835	ED0180701	44,1
	415	ED0180702	21,9

V125 and V160 - 80° Large V dies

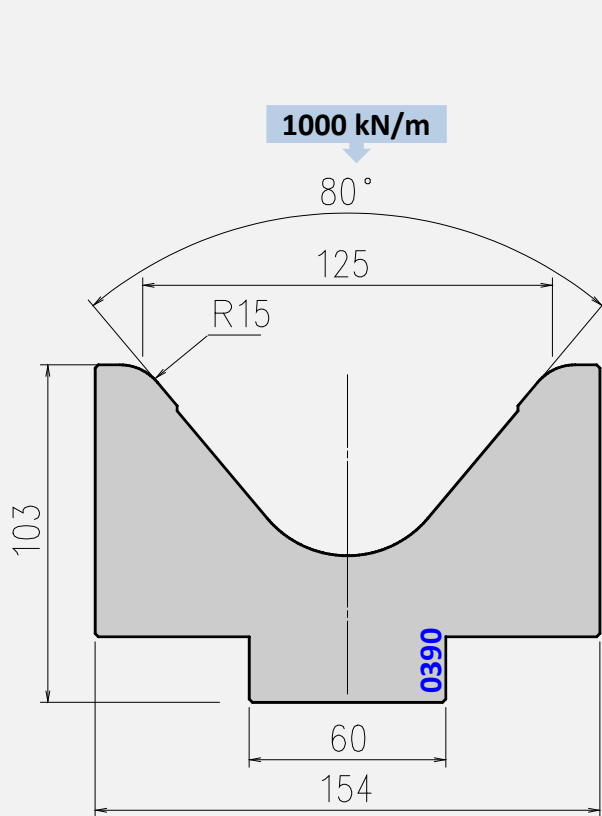
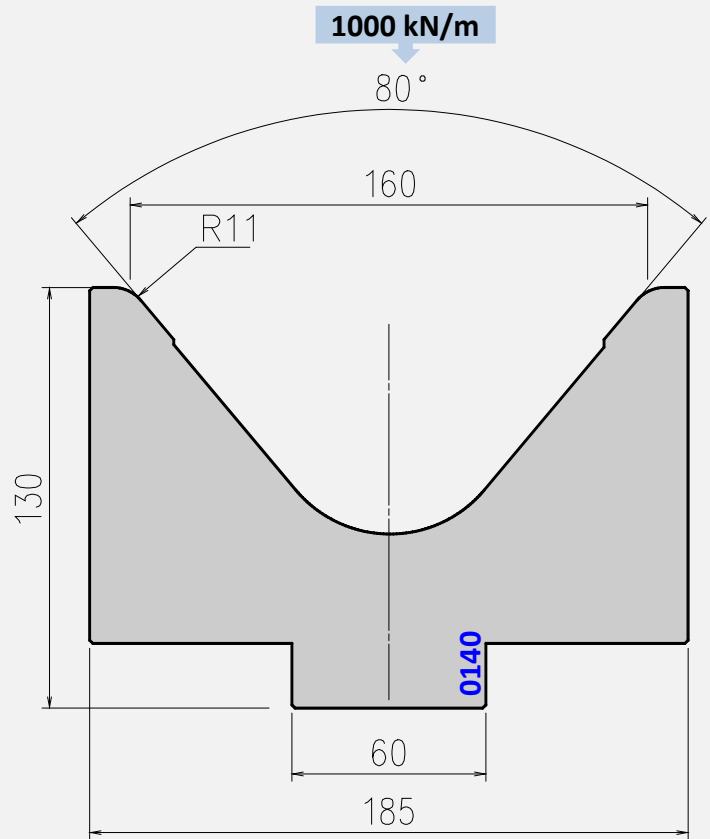
0390

0140

Hardness: 52-56 HRC; inductionhard.; Depth: 2mm

Tool angle	Length mm	Item No.	Weight Kg
80°	835	ED0390151	62,0
	415	ED0390152	30,8

Hardness: 52-56 HRC; inductionhard.; Depth: 2mm

Tool angle	Length mm	Item No.	Weight Kg
80°	835	ED0140111	92,6
	415	ED0140112	46,0

4V - 85° - 88°

4V - 60°

3U - 90°

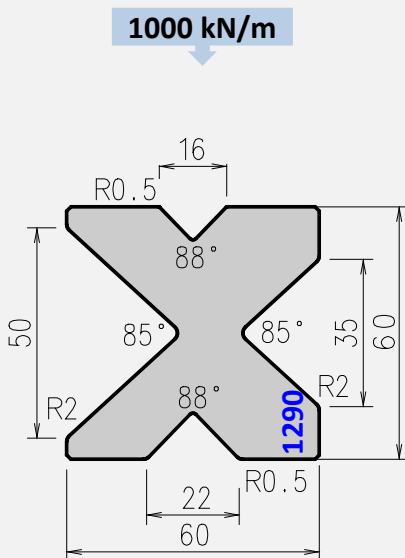
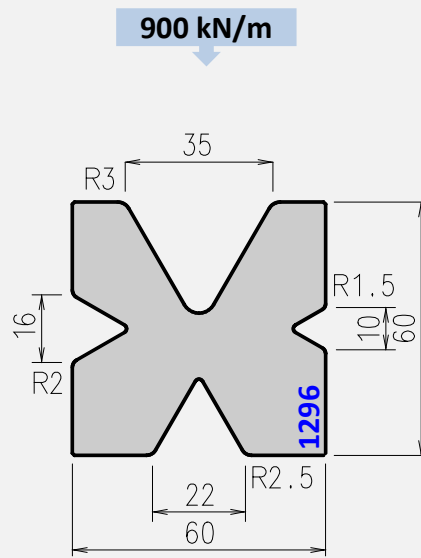
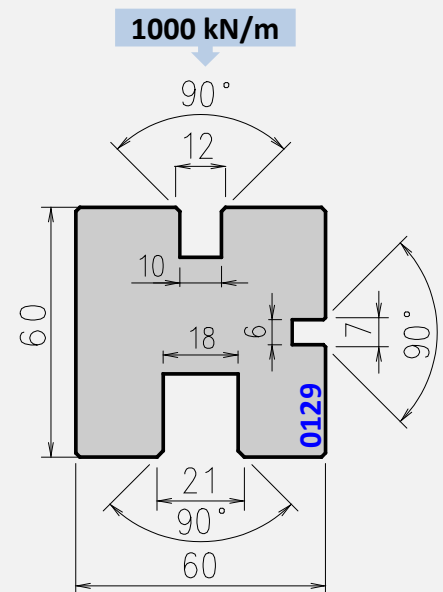
1290

1296

0129

Hardness: 52-56 HRC; inductionhard.; Depth: 2mm

Length mm	Item No.	Weight Kg
835	ED1290001	15,6
415	ED1290002	7,8

Hardness: 52-56 HRC; inductionhard.; Depth: 2mm

Item No.	Weight Kg
ED1296001	17,8
ED1296002	8,8

Hardness: 28-32 HRC; Throughhardened;

Item No.	Weight Kg
ED0129001	20,2
ED0129002	10,1

30° Hemming dies (V6 to V8)

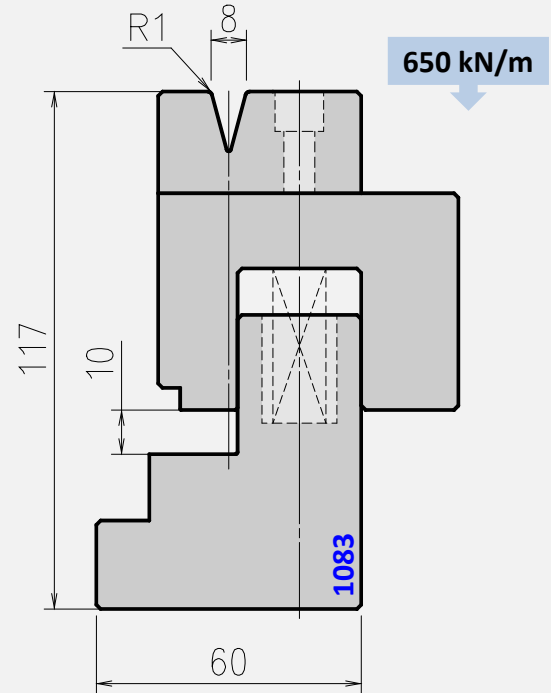
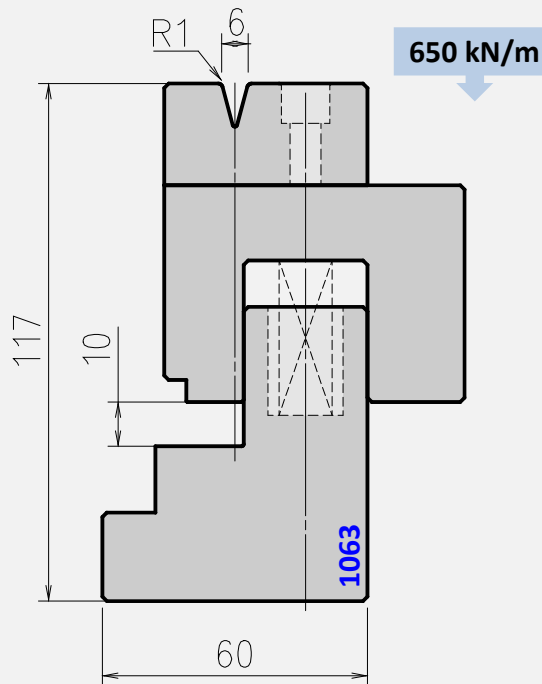

Tool angle	Length mm	Item No.	Weight Kg
30°	835	ED1063101	40,4
	415	ED1063102	20,1

Tool angle	Length mm	Item No.	Weight Kg
30°	835	ED1083101	40,2
	415	ED1083102	20,0

Replacement parts for 30° Hemming dies (V6 to V8)

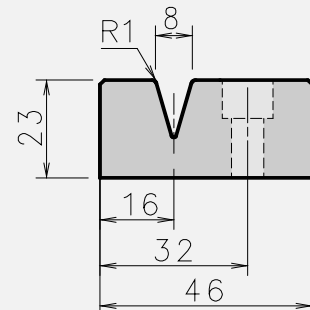
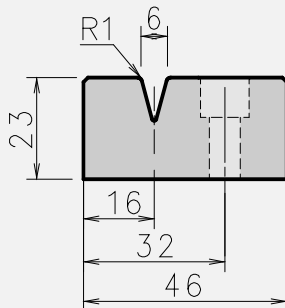

Tool angle	Length mm	Item No.	Weight Kg
30°	835	ED0063101	6,7
	415	ED0063102	3,3

Tool angle	Length mm	Item No.	Weight Kg
30°	835	ED0083101	6,5
	415	ED0083102	3,2

Tonnage required for hemming

Sheet thickness t mm	Mild steel (400 N/mm ²)			Stainless steel (600 N/mm ²)		
			Tonnage kN/m			Tonnage kN/m
	Tonnage kN/m	C mm	Tonnage kN/m	Tonnage kN/m	C mm	Tonnage kN/m
0,60	230	3	90	350	3	150
0,80	320	3	120	500	3	200
1,00	400	3,5	150	600	3,5	250
1,25	500	3,5	170	800	3,5	260
1,50	630	4,6	220	950	4,6	380
2,00	800	5,5	300	1300	5,5	500
2,50	900	6,5	550	1800	6,5	900
3,00	1000	8	700	2100	8	1000

26° Hemming dies (V10 to V12)

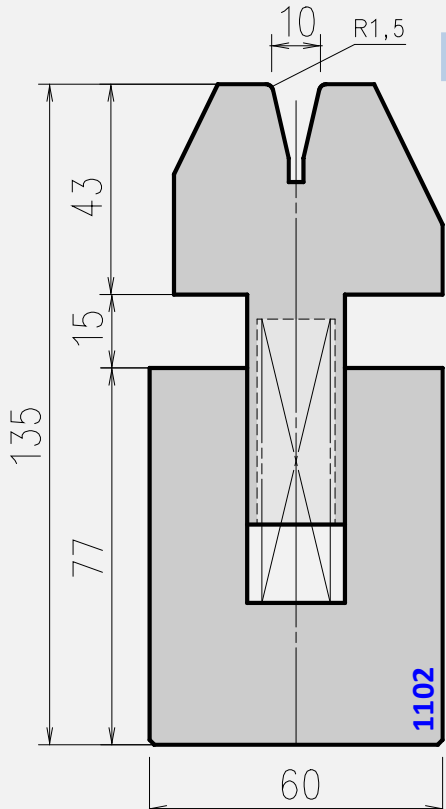

1000 kN/m

Hardness:
52-56 HRC
inductionhard.
Depth: 2mm

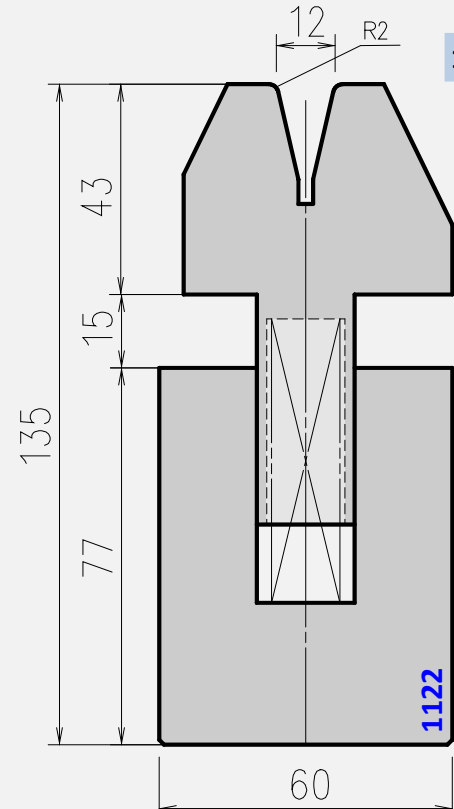

1000 kN/m

Hardness:
52-56 HRC
inductionhard.
Depth: 2mm

Tool angle	Length mm	Item No.	Weight Kg
26°	835	ED1102151	42,5
	415	ED1102152	21,1

Tool angle	Length mm	Item No.	Weight Kg
26°	835	ED1122201	42,1
	415	ED1122202	20,9

30° Hemming insert dies (V6 to V8)

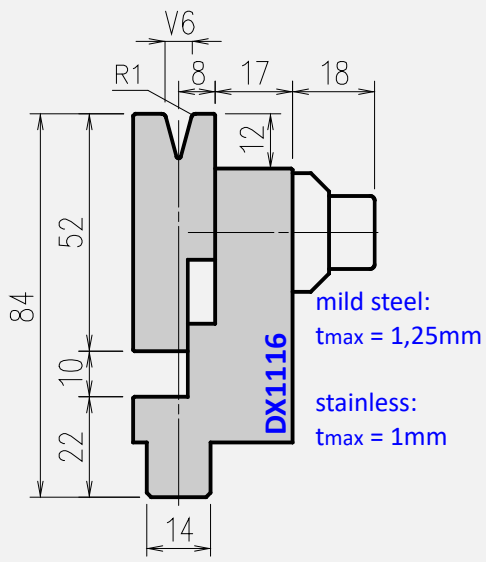

mild steel:
t_{max} = 1,25mm

stainless:
t_{max} = 1mm

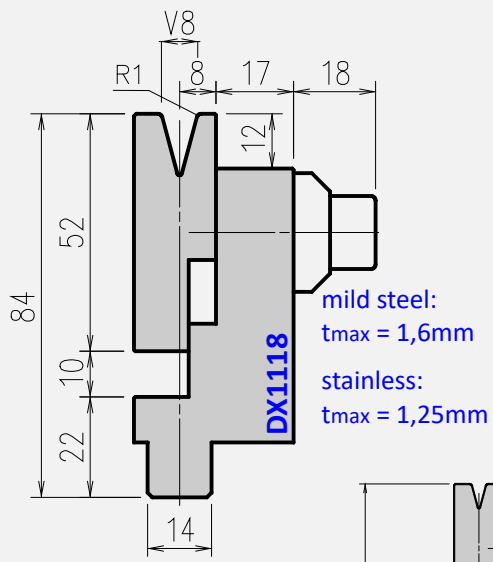

mild steel:
t_{max} = 1,6mm

stainless:
t_{max} = 1,25mm

Note:

- Tonnage for 30° prebending : 500 kN/m
- Tonnage for flattening 800 kN/m
- 470 Sect. = 45 + 2x50 + 55 + 60 + 65 + 70 + 75
- tool hardness HRC 36 to 42

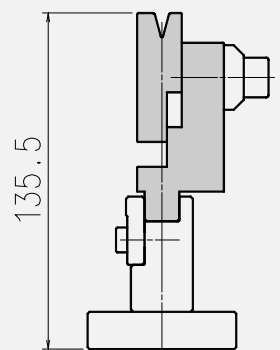

Tool angle	Length mm	Item No.	Weight Kg
30°	835	DX111601	16,0
	415	DX111602	8,0
	470 Sect.	DX111681	9,0

Tool angle	Length mm	Item No.	Weight Kg
30°	835	DX111801	16,0
	415	DX111802	8,0
	470 Sect.	DX111881	9,0

Pneumatic die holder (for standard and hemming bends)

The **pneumatic die holder** is a permanent fixture on the press brake machine and operates as:

- traditional die holder with standard (or special) dies for 90° or acute bends
- double decker hemming system with acute-angle dies. The pneumatic movement is considered as a programmable NC axis in the control system and ensures a rapid opening or closing.

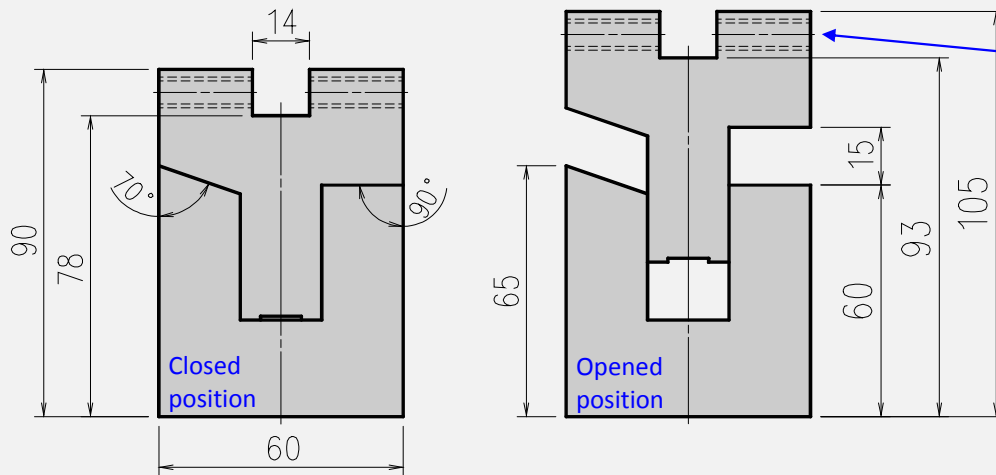

screw holes for mounting the optional clamps (during the use with large V dies)

Length mm	Item No.	Weight Kg
1250	T04066AN	50
2050	T04067AN	82
2550	T04068AN	102
3050	T04069AN	122
4050	T04070AN	162

Note:

- tonnage in closed position: up to 1000 kN/m, depends on die
- tonnage in opened position: up to 600 kN/m, depends on die
- die holder with induction hardened working surfaces (54-58 HRC)
- included accessories:
 - air distribution and regulation assy
 - relays 12V DC and 24V DC (according to your press brake)
 - air pipes and electric cables
 - temporary plates for easy installation
- please read operator's manual before installation

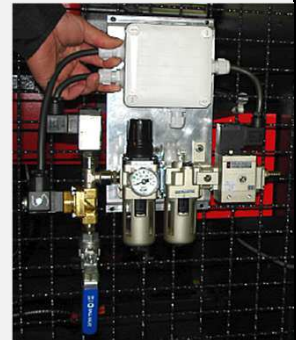

Optional clamps (with mounting hardware) for large V dies:

- for front side : T50001A and for rear side : T50002A
- please choose clamp quantity from the below table

For length	Front side	Rear side
1250 mm	6	6
2050 mm	10	10
2550 mm	13	13
3050 mm	15	15
4050 mm	20	20

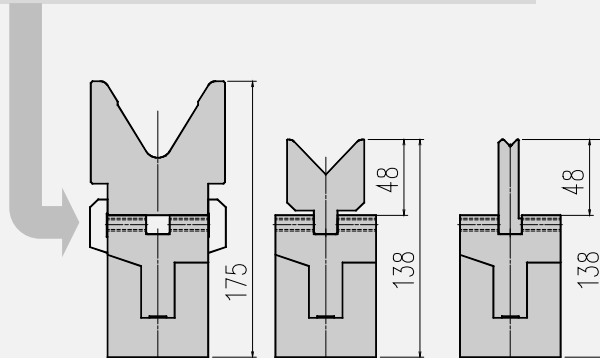

Use for standard bends: closed position

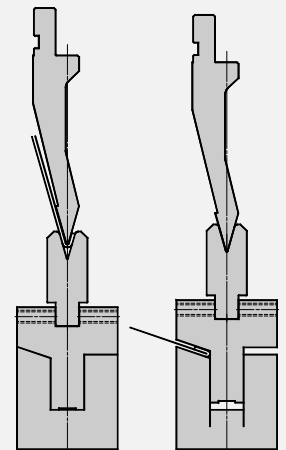

Use for hemming: closed and opened position



ATC tooling Line-up:

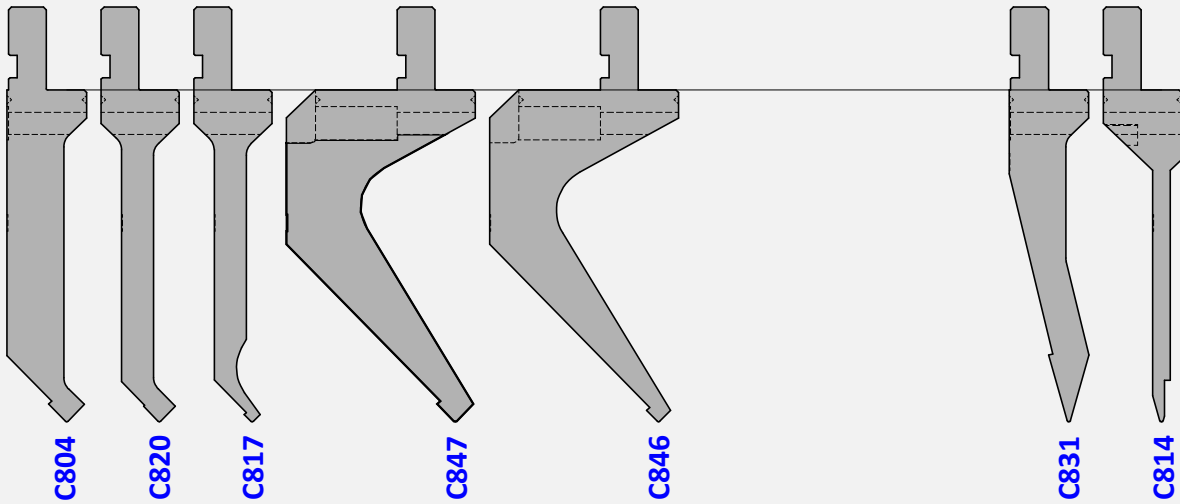

86° - 84° tools (V4 - V40)

30° tools (V6 - V12)

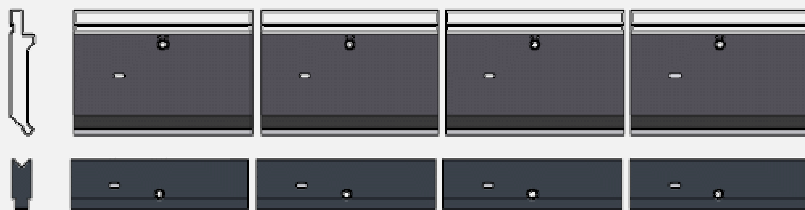
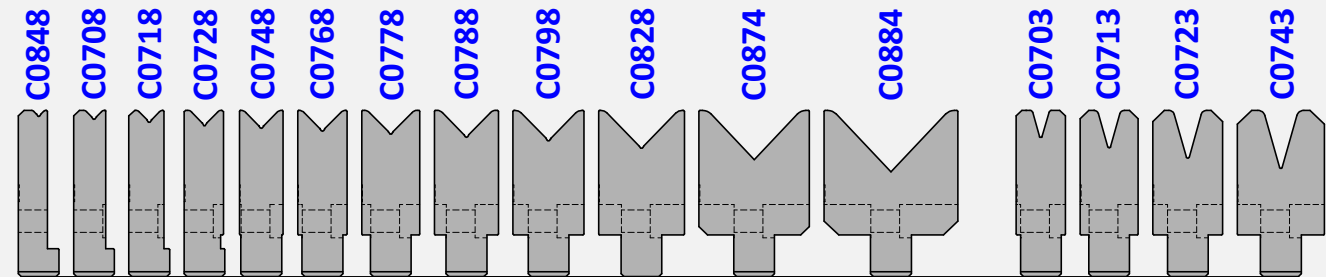

200 Division = 4x200mm = 800mm



Short Division = 2x15; 2x20; 2x25; 2x40; 2x50; 2x100 = 500mm
(V32; V40 dies = 2x20; 2x25; 2x30; 2x40; 2x50; 2x100 = 530mm)

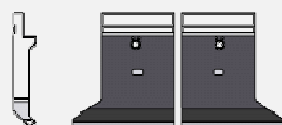

Ears = 125 Left ear; 125 Right ear = 250mm

AFH ATC Standard Punch C804 (9 mm tip)

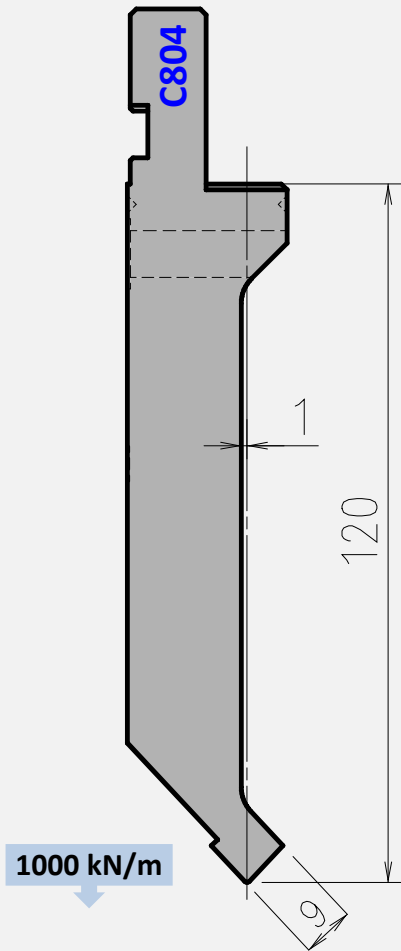

Tool angle	Tip radius	Length mm	Item No.	Weight Kg
86°	R0.6	200 Div.	C8048065	16,3
		Short Div.	C8048066	10,1
		Ears	C8048067	3,8
	R3	200 Div.	C8048305	16,3
		Short Div.	C8048306	10,1
		Ears	C8048307	3,8

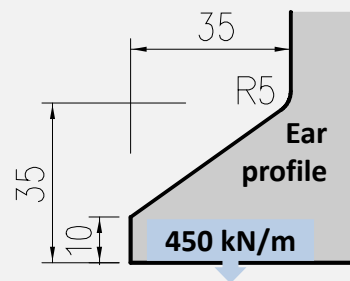

AFH ATC Gooseneck Punch C847 (9 mm tip)

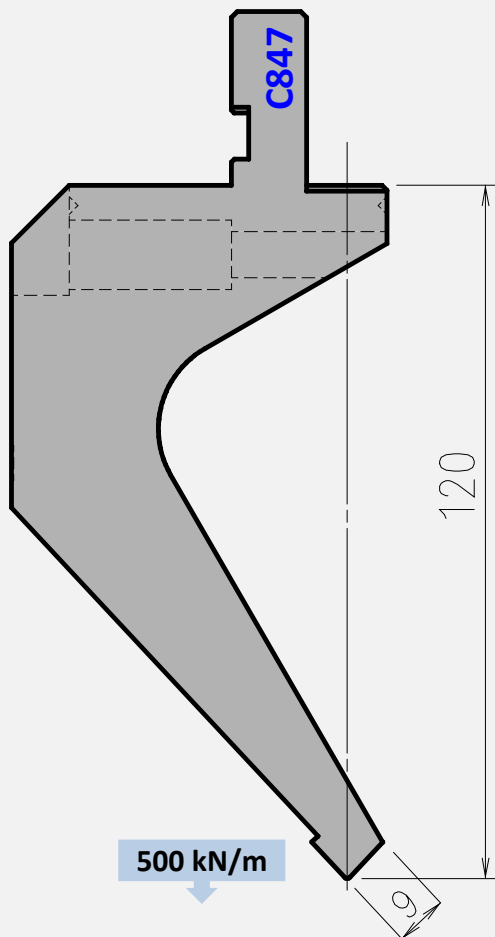

Tool angle	Tip radius	Length mm	Item No.	Weight Kg
86°	R0.6	200 Div.	C8478065	23,9
		Short Div.	C8478066	14,5
		Ears	C8478067	5,5
	R3	200 Div.	C8478305	23,9
		Short Div.	C8478306	14,5
		Ears	C8478307	5,5

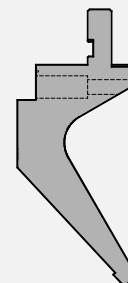

Shape of Gooseneck Punch 15mm Segment

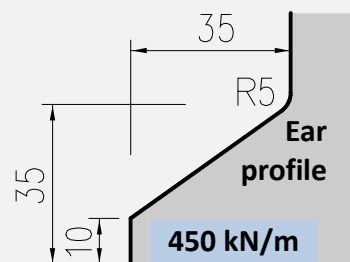

AFH ATC Sash Punch C820 (8 mm tip)

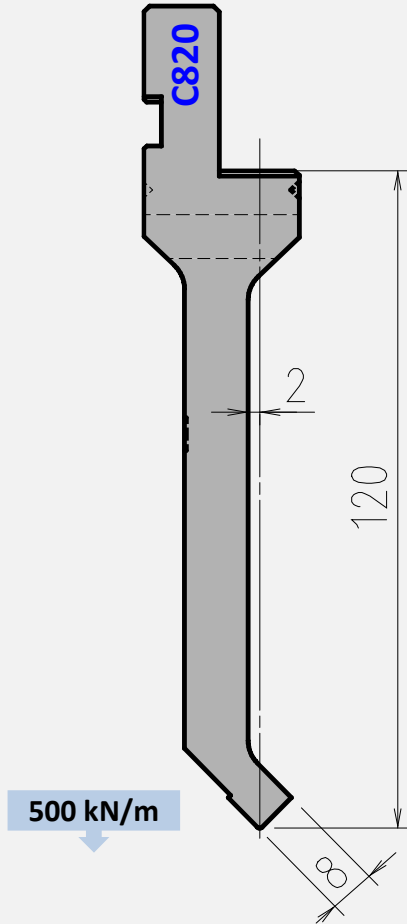

Tool angle	Tip radius	Length mm	Item No.	Weight Kg
86°	R0.6	200 Div.	C8208065	11,9
		Short Div.	C8208066	7,3
		Ears	C8208067	3,0

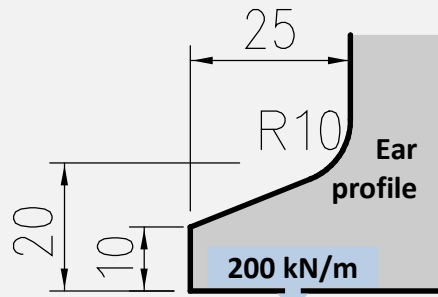

AFH ATC Thin Sash Punch C817 (4 mm tip)

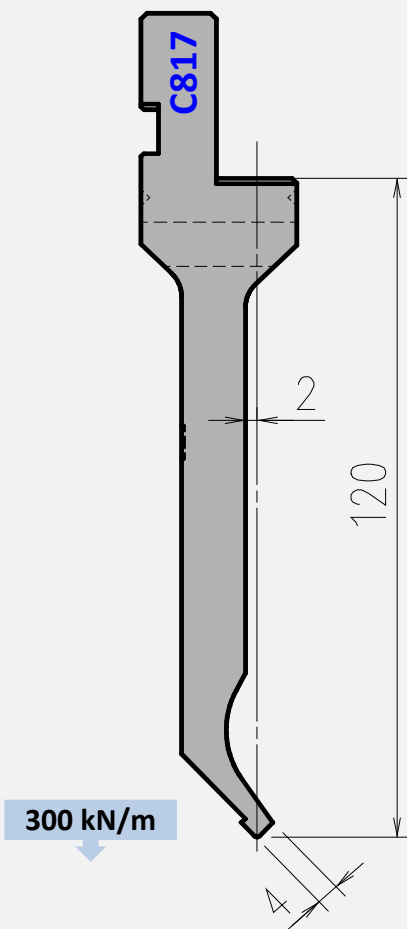

Tool angle	Tip radius	Length mm	Item No.	Weight Kg
86°	R0.6	200 Div.	C8178065	11,4
		Short Div.	C8178066	7,0
		Ears	C8178067	3,3

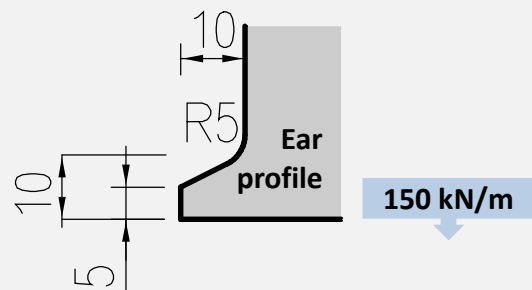

AFH ATC Thin Gooseneck Punch C846 (6 mm tip)

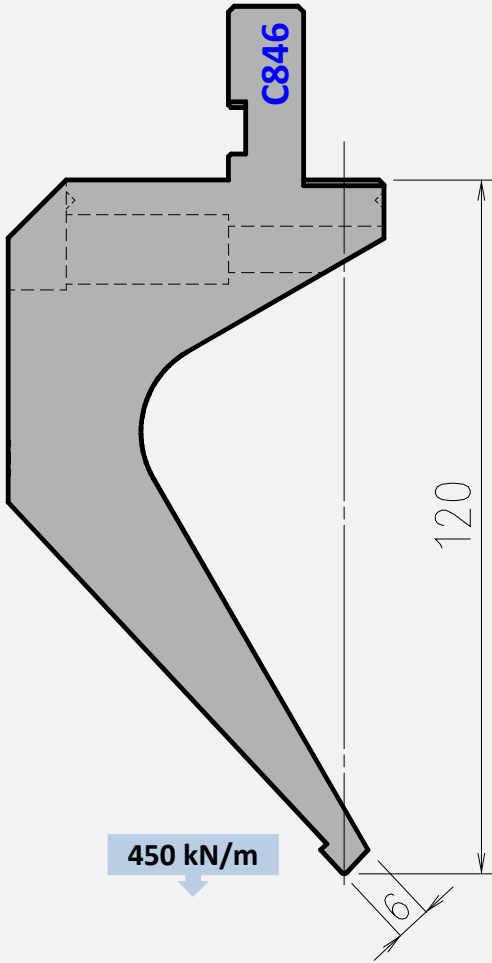

Tool angle	Tip radius	Length mm	Item No.	Weight Kg
86°	R0.6	200 Div.	C8468065	22,2
		Short Div.	C8468066	13,4
		Ears	C8468067	5,1

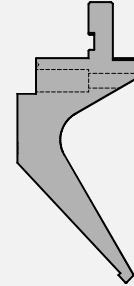

Shape of Gooseneck Punch 15mm Segment

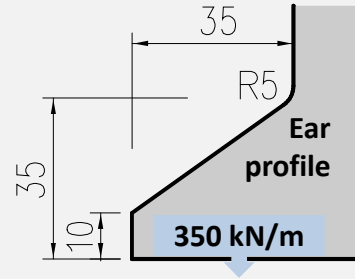

AFH ATC Acute Angle Punch C814

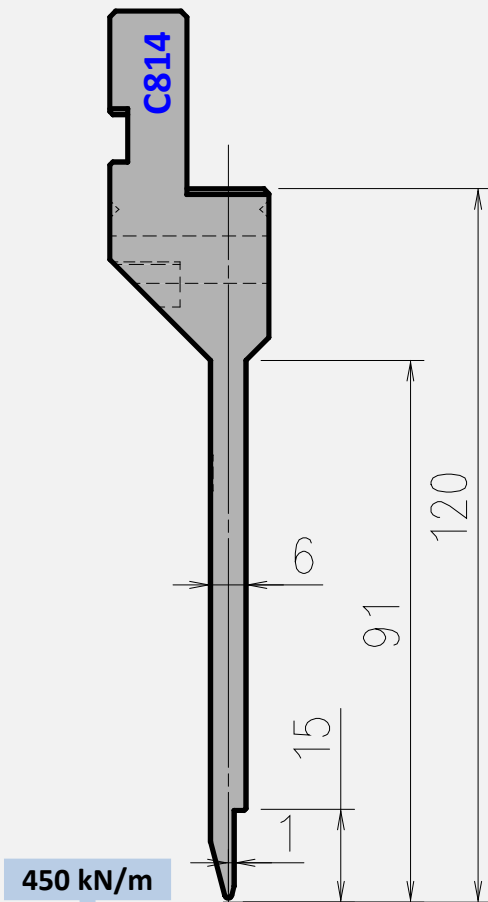

Tool angle	Tip radius	Length mm	Item No.	Weight Kg
30°	R0.6	200 Div.	C8143065	9,3
		Short Div.	C8143066	5,7
		Ears	C8143067	2,3

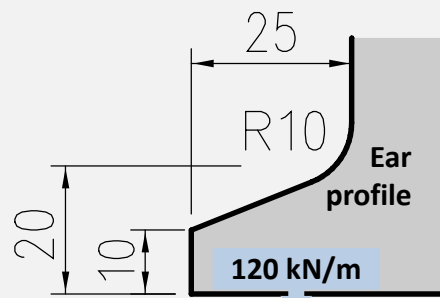

AFH ATC Hemming Punch C831

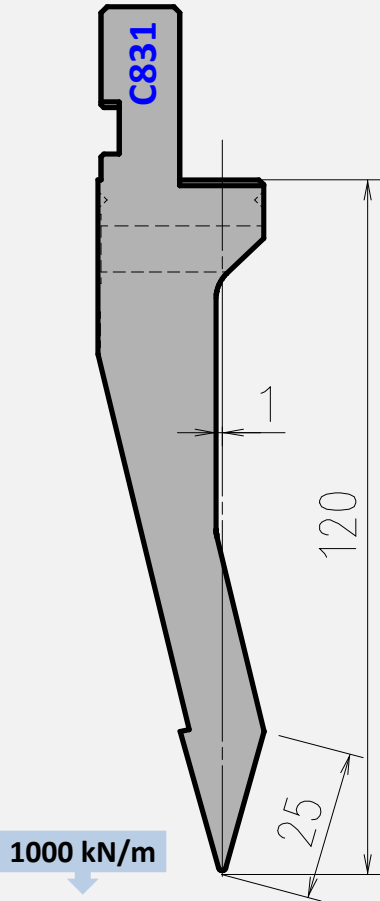

Tool angle	Tip radius	Length mm	Item No.	Weight Kg
30°	R0.6	200 Div.	C8313065	13,5
		Short Div.	C8313066	8,3
		Ears	C8313067	3,6
	R3	200 Div.	C8313305	13,5
		Short Div.	C8313306	8,3
		Ears	C8313307	3,6

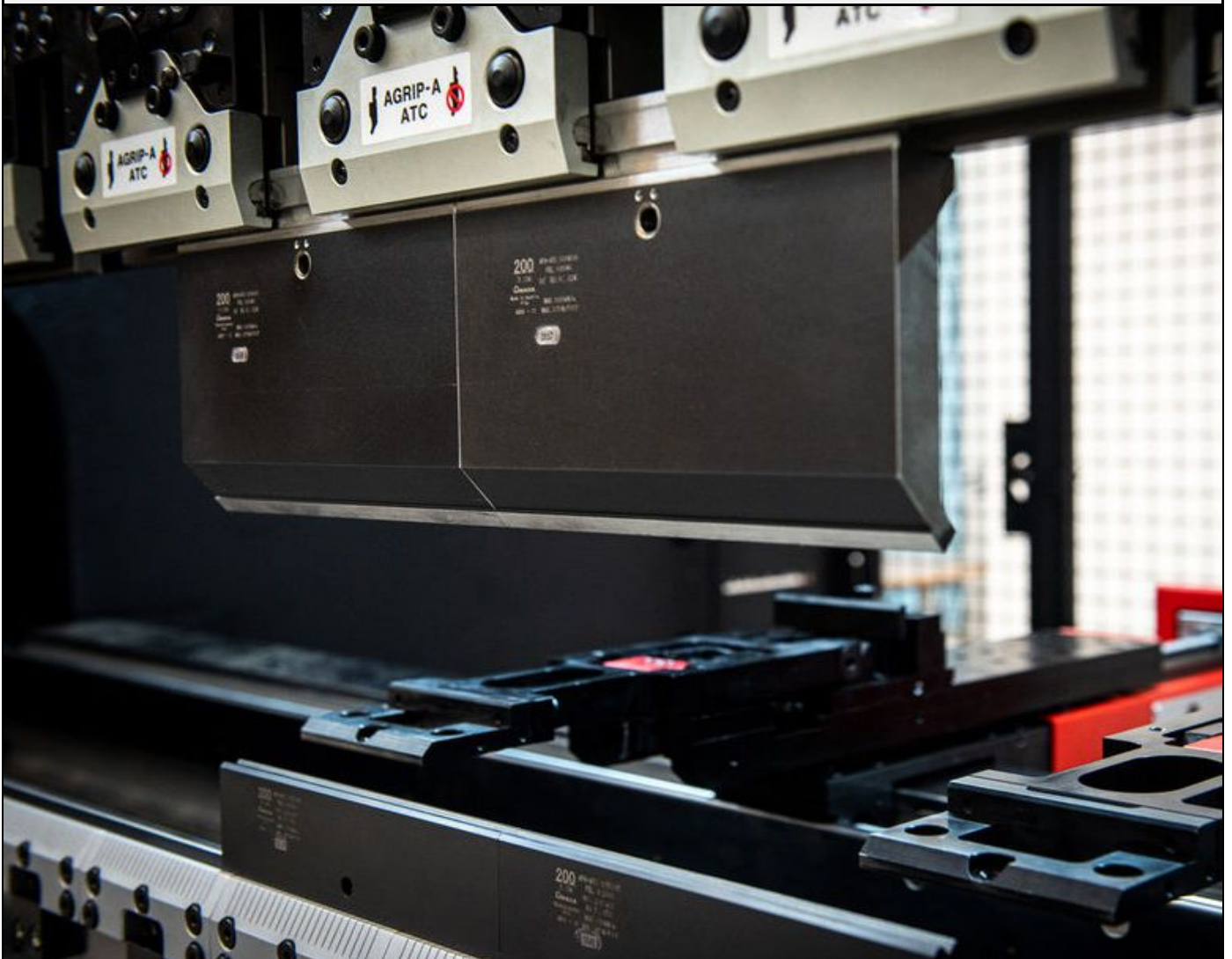
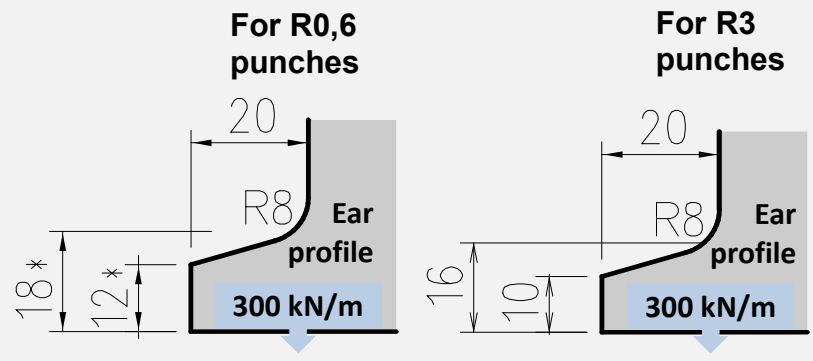

AFH ATC Die C0703 (V 6)

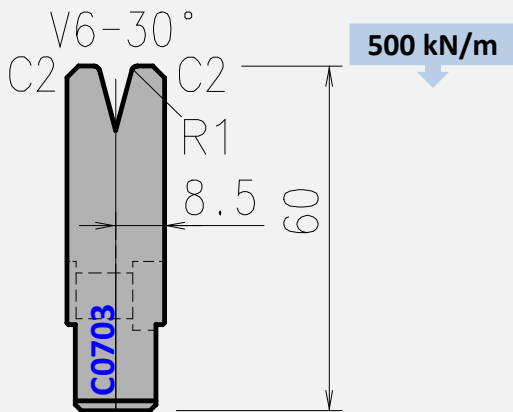

Tool angle	Length mm	Item No.	Weight Kg
30°	200 Div.	C0703105	5,8
	Short Div.	C0703106	3,5

AFH ATC Die C0713 (V 8)

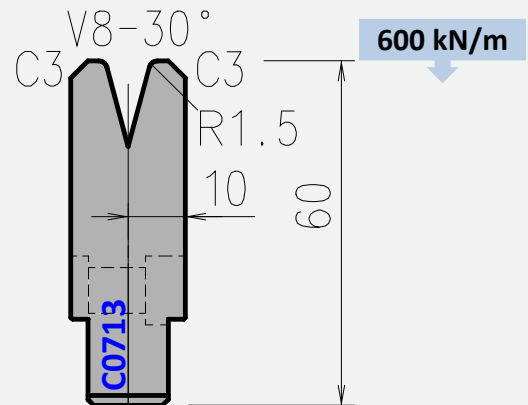

Tool angle	Length mm	Item No.	Weight Kg
30°	200 Div.	C0713155	6,5
	Short Div.	C0713156	3,9

AFH ATC Die C0723 (V 10)

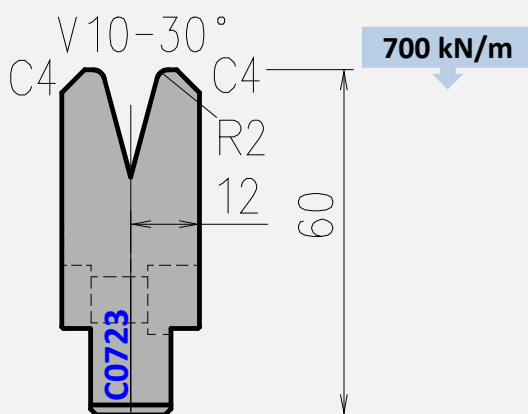

Tool angle	Length mm	Item No.	Weight Kg
30°	200 Div.	C0723205	7,3
	Short Div.	C0723206	4,4

AFH ATC Die C0743 (V 12)

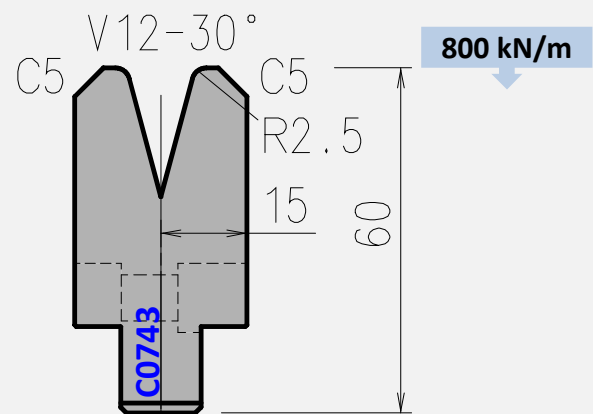

Tool angle	Length mm	Item No.	Weight Kg
30°	200 Div.	C0743255	8,7
	Short Div.	C0743256	5,2

AFH ATC Die C0848 (V 4)

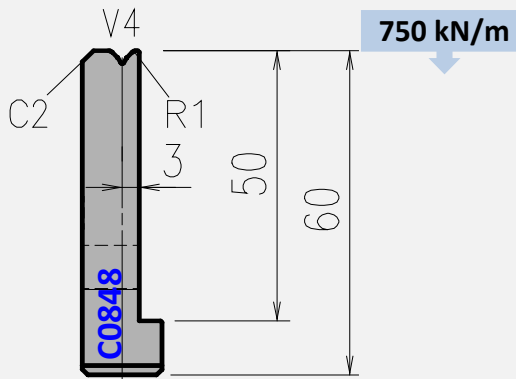

Tool angle	Length mm	Item No.	Weight Kg
86°	200 Div.	C0848105	4,0
	Short Div.	C0848106	2,4

AFH ATC Die C0708 (V 6)

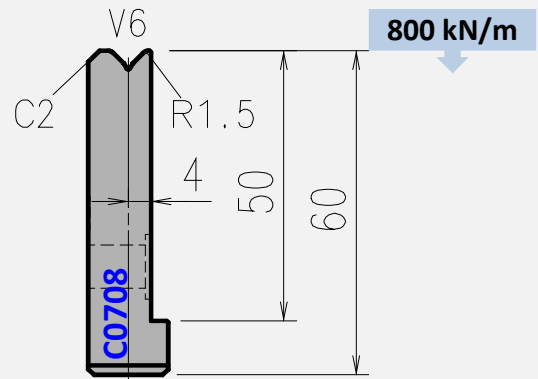

Tool angle	Length mm	Item No.	Weight Kg
86°	200 Div.	C0708155	4,2
	Short Div.	C0708156	2,6

AFH ATC Die C0718 (V 8)

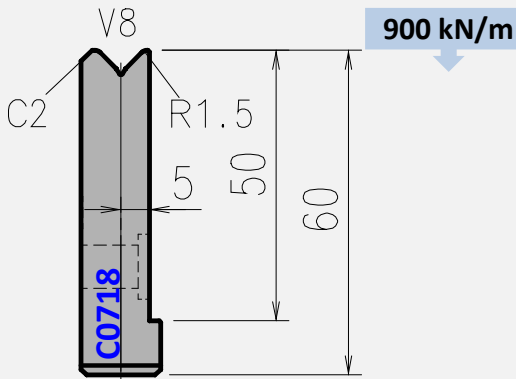

Tool angle	Length mm	Item No.	Weight Kg
86°	200 Div.	C0718155	4,5
	Short Div.	C0718156	2,8

AFH ATC Die C0728 (V 10)

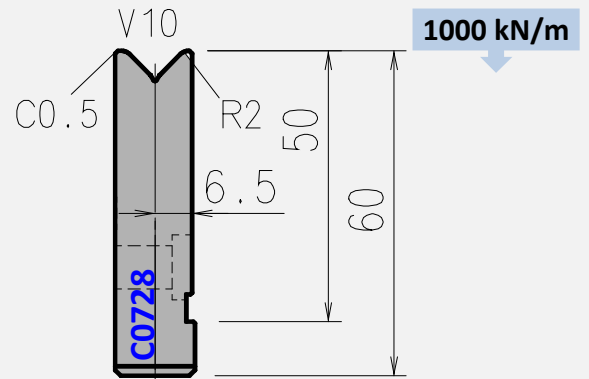

Tool angle	Length mm	Item No.	Weight Kg
86°	200 Div.	C0728205	4,9
	Short Div.	C0728206	3,0

AFH ATC Die C0748 (V 12)

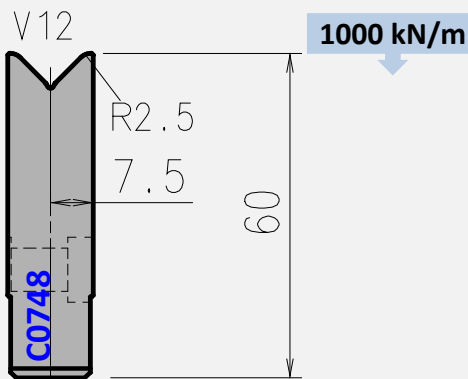

Tool angle	Length mm	Item No.	Weight Kg
86°	200 Div.	C0748255	5,2
	Short Div.	C0748256	3,2

AFH ATC Die C0768 (V 14)

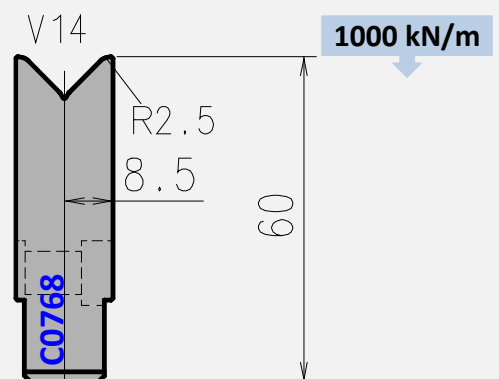

Tool angle	Length mm	Item No.	Weight Kg
86°	200 Div.	C0768255	5,7
	Short Div.	C0768256	3,5

AFH ATC Die C0778 (V 16)

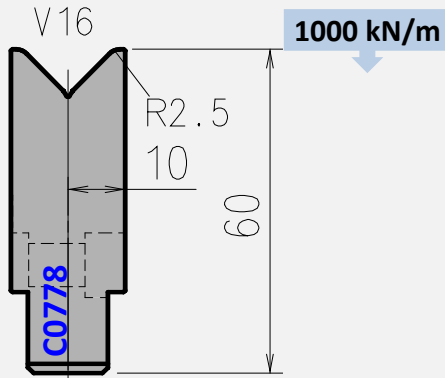

Tool angle	Length mm	Item No.	Weight Kg
86°	200 Div.	C0778255	6,4
	Short Div.	C0778256	3,9

AFH ATC Die C0788 (V 18)

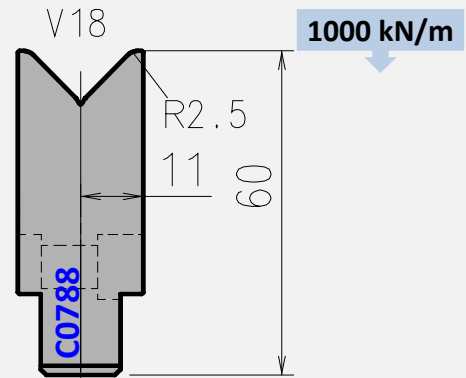

Tool angle	Length mm	Item No.	Weight Kg
86°	200 Div.	C0788255	6,9
	Short Div.	C0788256	4,2

AFH ATC Die C0798 (V 20)

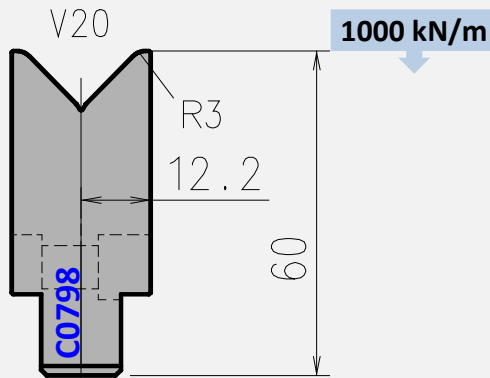

Tool angle	Length mm	Item No.	Weight Kg
86°	200 Div.	C0798305	7,4
	Short Div.	C0798306	4,5

AFH ATC Die C0828 (V 25)

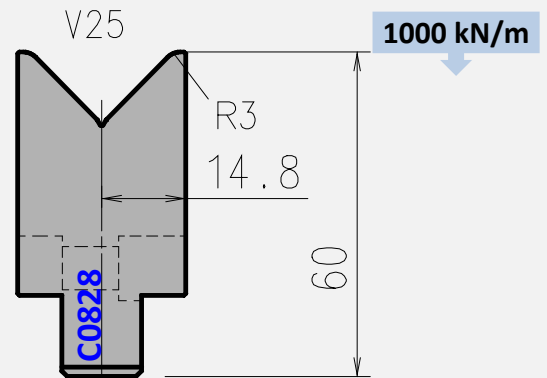

Tool angle	Length mm	Item No.	Weight Kg
86°	200 Div.	C0828305	8,5
	Short Div.	C0828306	5,1

AFH ATC Die C0874 (V 32)

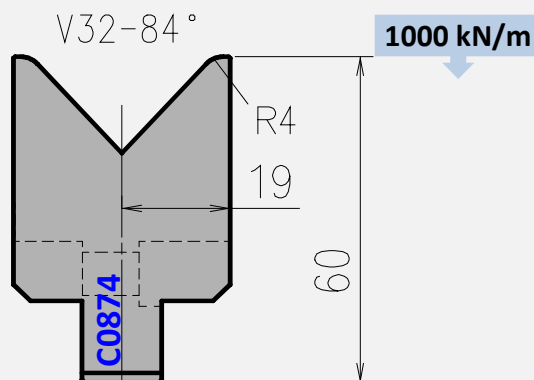

Tool angle	Length mm	Item No.	Weight Kg
84°	200 Div.	C0874405	10,1
	Short Div.	C0874406	6,4

AFH ATC Die C0884 (V 40)

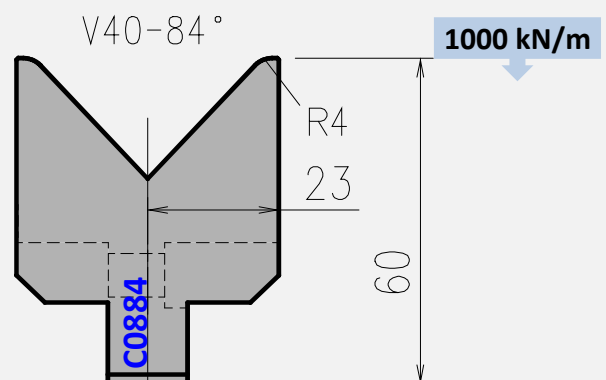

Tool angle	Length mm	Item No.	Weight Kg
84°	200 Div.	C0884405	11,2
	Short Div.	C0884406	7,1

(Short division for V32; V40 dies = 2x20; 2x25; 2x30; 2x40; 2x50; 2x100 = 530mm)

V4	V6	V8
----	----	----

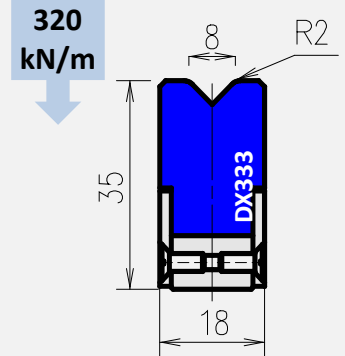
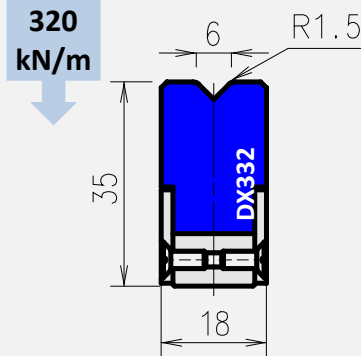
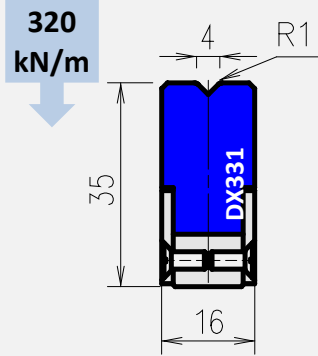

Tool angle	L mm	Item No.	Weight Kg	Tool angle	L mm	Item No.	Weight Kg	Tool angle	L mm	Item No.	Weight Kg
90°	835	DX331001	1,2	90°	835	DX332001	1,4	88°	835	DX333001	1,4
	415	DX331002	0,6		415	DX332002	0,7		415	DX333002	0,7

V10	V12
-----	-----

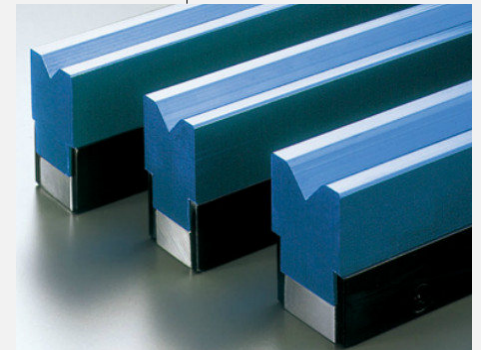
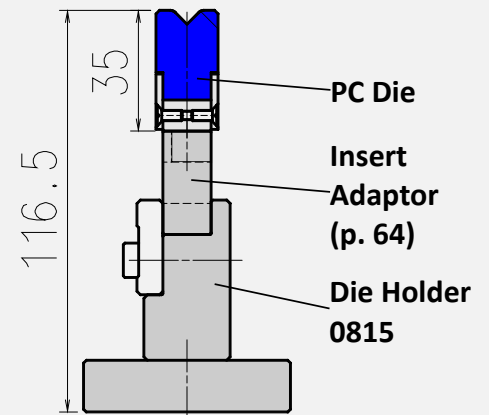
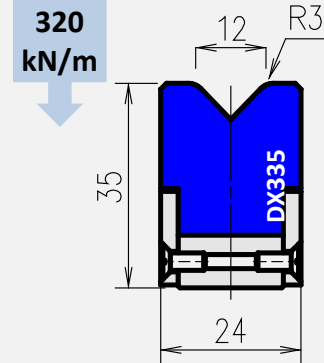
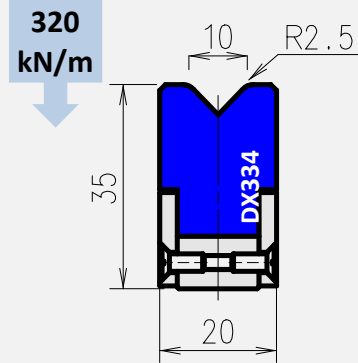

Tool angle	L mm	Item No.	Weight Kg	Tool angle	L mm	Item No.	Weight Kg
88°	835	DX334001	1,6	88°	835	DX335001	2,0
	415	DX334002	0,8		415	DX335002	1,0

V32	V40	V50
-----	-----	-----

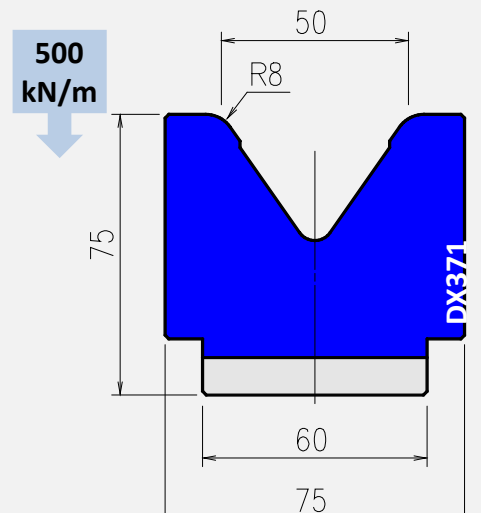
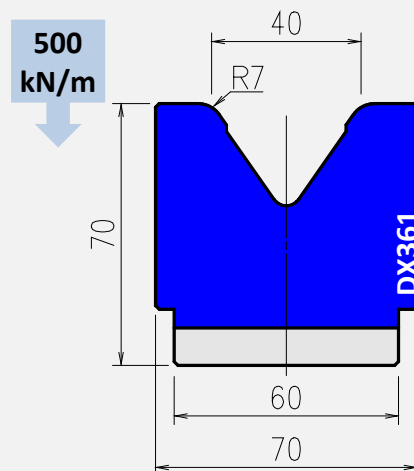
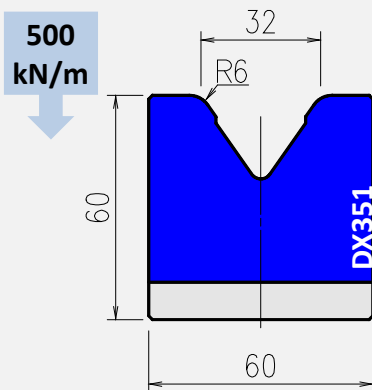

Tool angle	L mm	Item No.	Weight Kg	Tool angle	L mm	Item No.	Weight Kg	Tool angle	L mm	Item No.	Weight Kg
70°	835	DX351001	8,4	70°	835	DX361001	9,2	70°	835	DX371001	9,5
	415	DX351002	4,2		415	DX361002	4,6		415	DX371002	4,7

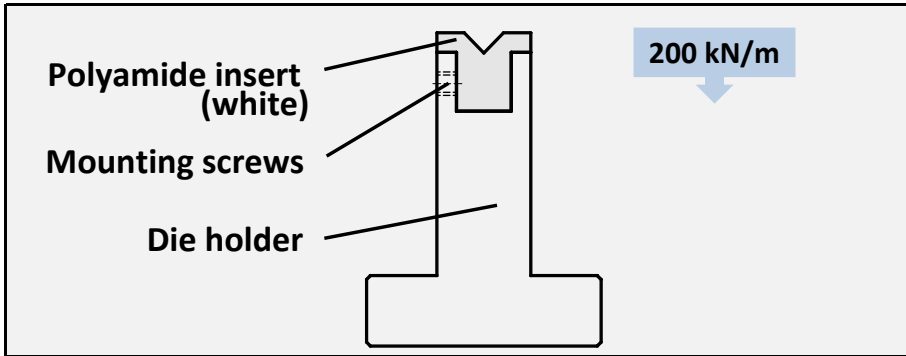

Holder for inserts W38

	L mm	Item No.	Weight Kg
W38	834	PT300001	20,5
	414	PT300002	10,2

Holder for inserts W24

	L mm	Item No.	Weight Kg
W24	834	PT100001	14,6
	414	PT100002	7,3

Holder for inserts W35

	L mm	Item No.	Weight Kg
W35	834	PT200001	17,6
	414	PT200002	8,7

Polyamide inserts W38

Polyamide inserts W24

Polyamide inserts W35

A°	V	L mm	Item No.	Weight Kg	
88°	6	835	PT306881	1,0	
		415	PT306882	0,5	
	8	835	PT308881	1,0	
		415	PT308882	0,5	
	10	835	PT310881	1,0	
		415	PT310882	0,5	
12	835	PT312881	0,9		
	415	PT312882	0,5		
60°	16	835	PT316881	1,0	
		415	PT316882	0,5	
	20	835	PT320881	0,9	
		415	PT320882	0,5	
	25	835	PT325881	0,9	
		415	PT325882	0,5	
30°	6	835	PT306601	1,0	
		415	PT306602	0,5	
	8	835	PT308601	1,0	
		415	PT308602	0,5	
	10	835	PT310601	1,0	
		415	PT310602	0,5	
12	835	PT312601	1,0		
	415	PT312602	0,5		
88°	16	835	PT316601	0,9	
		415	PT316602	0,5	
	20	835	PT320601	0,9	
		415	PT320602	0,5	
	60°	6	835	PT306301	1,0
			415	PT306302	0,5
8		835	PT308301	1,0	
		415	PT308302	0,5	
10		835	PT310301	0,9	
		415	PT310302	0,5	
12	835	PT312301	0,9		
	415	PT312302	0,5		
30°	16	835	PT316301	0,8	
		415	PT316302	0,4	

A°	V	L mm	Item No.	Weight Kg
88°	6	835	PT106881	0,3
		415	PT106882	0,2
	8	835	PT108881	0,3
		415	PT108882	0,2
	10	835	PT110881	0,3
		415	PT110882	0,2
60°	6	835	PT106601	0,3
		415	PT106602	0,2
	8	835	PT108601	0,3
		415	PT108602	0,2
	10	835	PT110601	0,3
		415	PT110602	0,2
30°	6	835	PT106301	0,3
		415	PT106302	0,2
	8	835	PT108301	0,3
		415	PT108302	0,2

Pad Holder 25

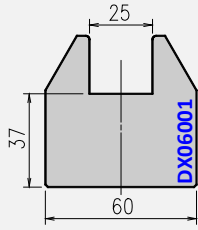

Tonnage depends on application

L mm	Item No.	Weight Kg
835	DX060011	21
415	DX060012	10,5

Urethane Pad 25

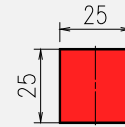

	L mm	Item No.	Weight Kg
Red Shore A 80°	835	DX061111	1
	415	DX061112	0,5
Blue Shore A 90°	835	DX061121	1
	415	DX061122	0,5

Pad Holder 30

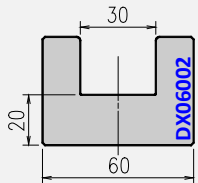

Tonnage depends on application

L mm	Item No.	Weight Kg
835	DX060021	15
415	DX060022	7,5

Urethane Pad 30

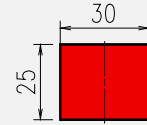

	L mm	Item No.	Weight Kg
Red Shore A 80°	835	DX061211	1
	415	DX061212	0,5
Blue Shore A 90°	835	DX061221	1
	415	DX061222	0,5

Pad Holder 50

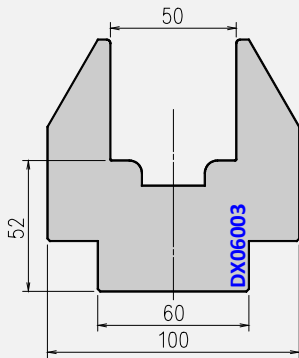

Tonnage depends on application

L mm	Item No.	Weight Kg
835	DX060031	45
415	DX060032	22,5

Urethane Pad 50

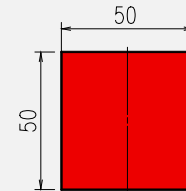

	L mm	Item No.	Weight Kg
Red Shore A 80°	835	DX061311	3
	415	DX061312	1,5
Blue Shore A 90°	835	DX061321	3
	415	DX061322	1,5

Pad Holder 80

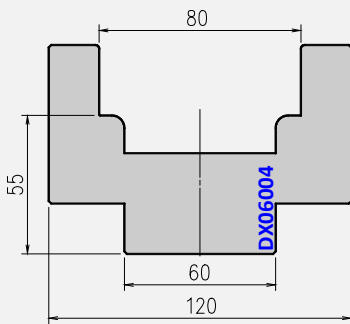

Tonnage depends on application

L mm	Item No.	Weight Kg
835	DX060041	55
415	DX060042	27,5

Urethane Pad 80

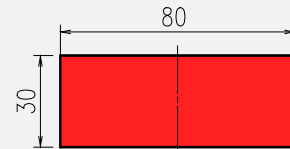

	L mm	Item No.	Weight Kg
Red Shore A 80°	835	DX061411	3
	415	DX061412	1,5
Blue Shore A 90°	835	DX061421	3
	415	DX061422	1,5

Pad Holder 110

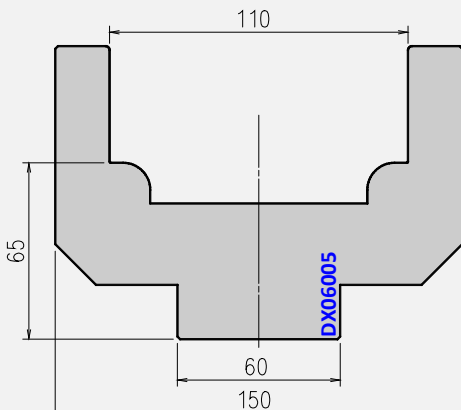

Tonnage depends on application

L mm	Item No.	Weight Kg
835	DX060051	62
415	DX060052	31

Urethane Pad 110

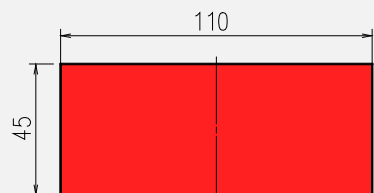

	L mm	Item No.	Weight Kg
Red Shore A 80°	835	DX061511	5
	415	DX061512	2,5
Blue Shore A 90°	835	DX061521	5
	415	DX061522	2,5

Urethane Sheet (RED)

0,3mm x 150mm

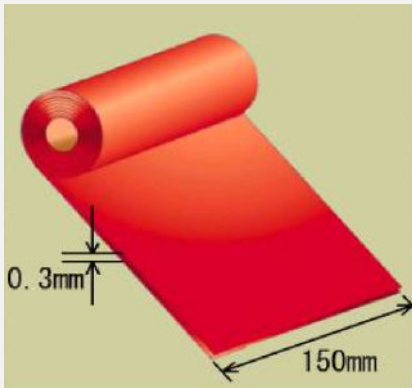

Item No.	L m
AC426201	-

0,5mm x 150mm

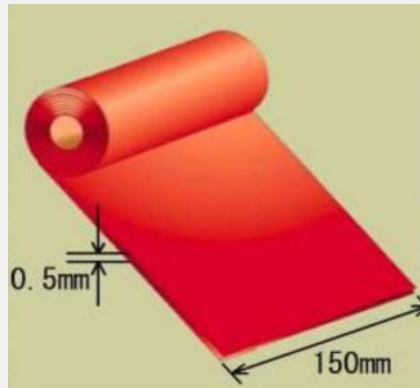

Item No.	L m
AC426191	-

1 mm x 150mm

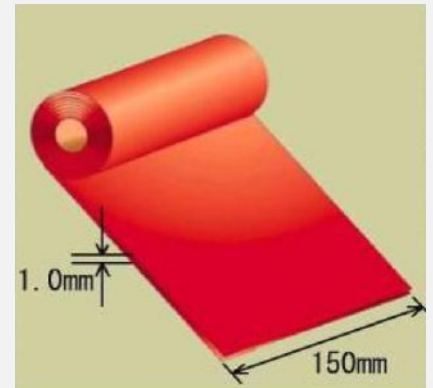

Item No.	L m
AC426181	-

Note: Please provide required length when ordering

Adhesive Strip (WHITE 0,3 mm)

Item No.	L m
AC909910	10

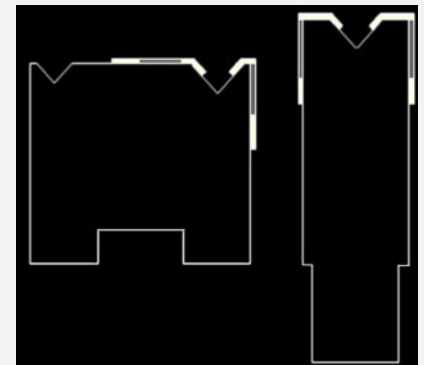
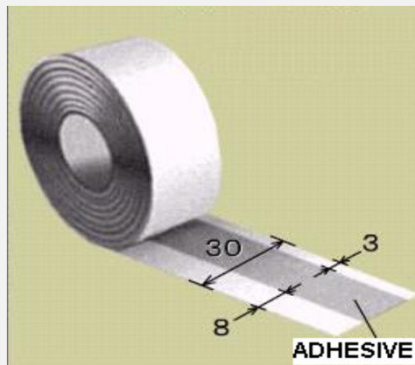
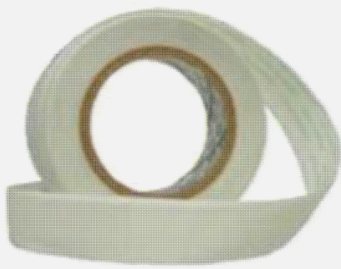

Urethane Cap (YELLOW 0,5 mm)

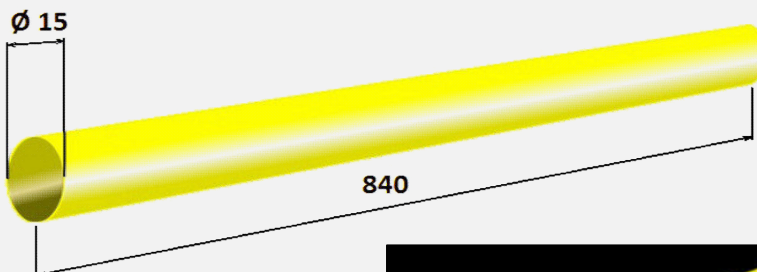

Item No.	Length
AC909930	840mm x 5 off as set

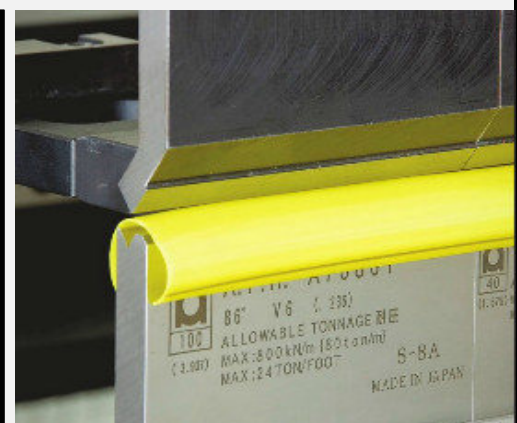
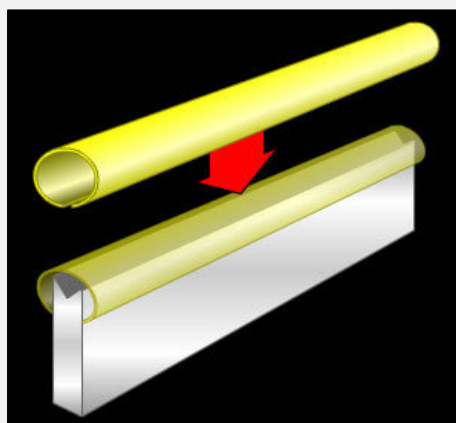

Die Holder 0815

Length mm	Item No.	Weight Kg
L=840mm	EH0815001	12,4
S=420mm	EH0815002	6,2

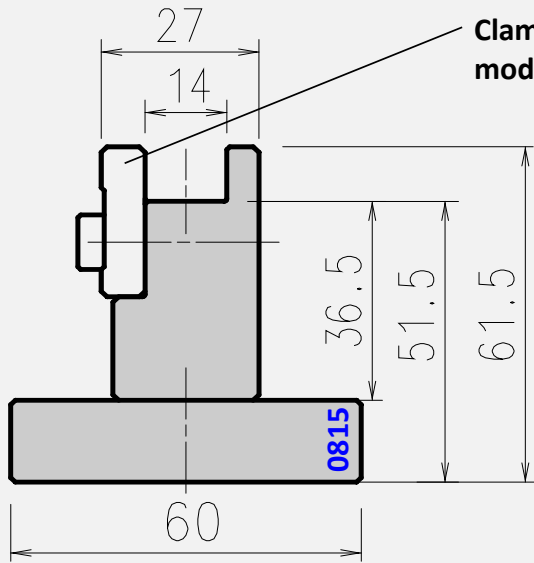

Clamp piece usable for insert mode and for clamp mode

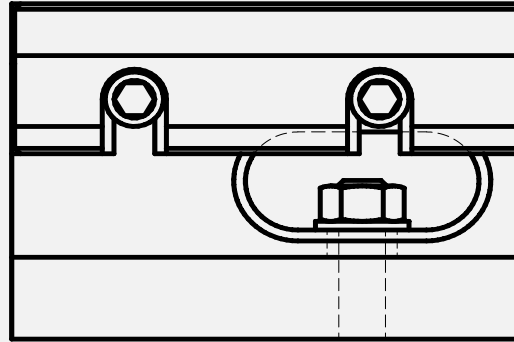

1000 kN/m

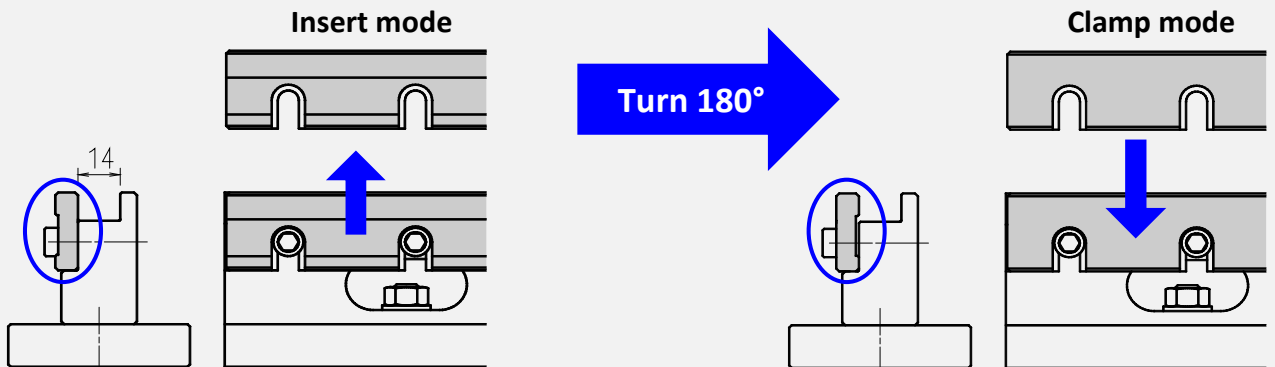

ED 0743251

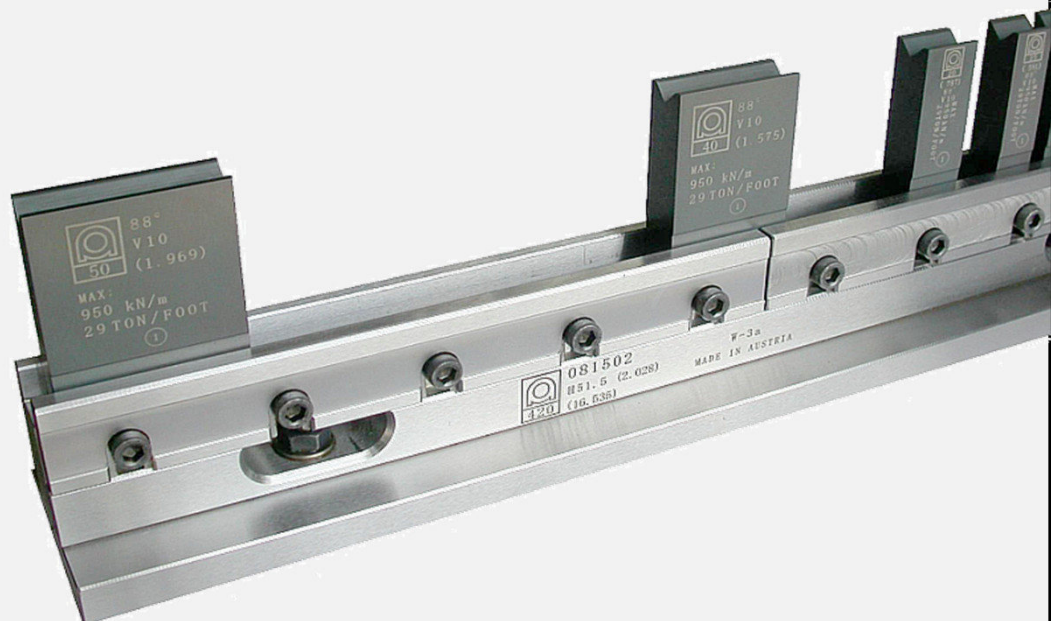
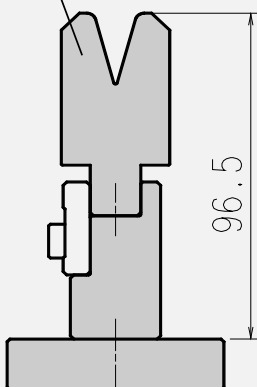

Die Holder FEAT

Length mm	Item No.	Weight Kg
L=850mm	DX082501	13,5
S=510mm	DX082502	8,0

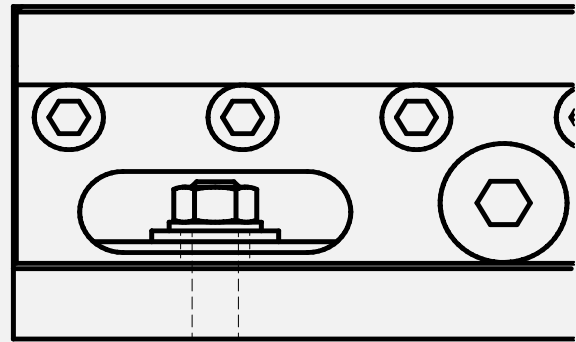
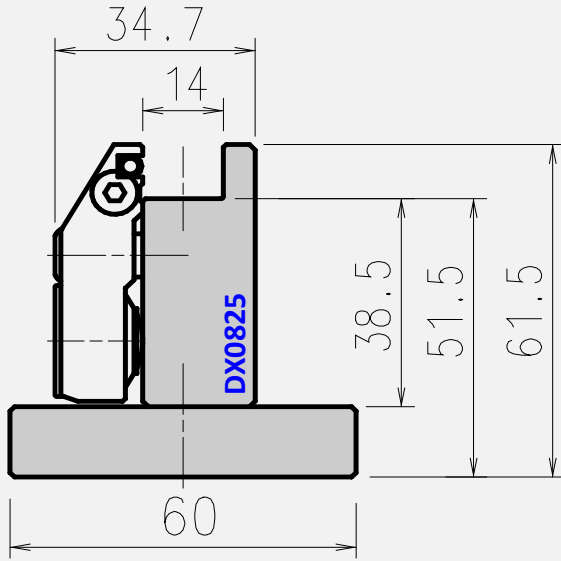

Die are clamped by rotating 5 bolts by 180°.



Clamping check for security: An indicator (red circle) appears in unclamping state. (2 indicators per clamp plate)

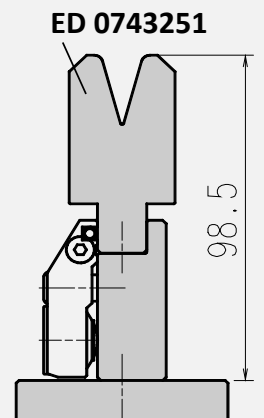
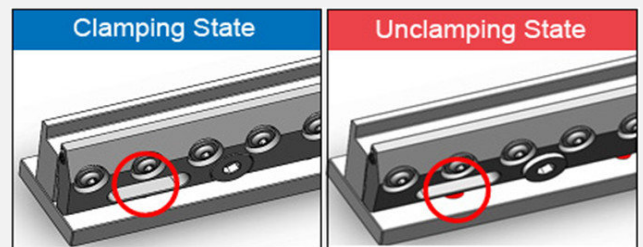

Die Holder 5340

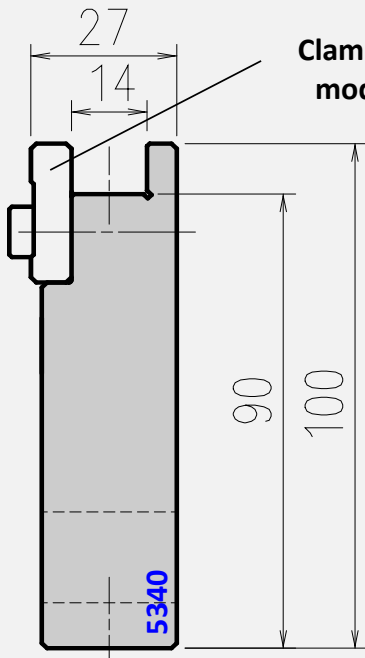

Clamp piece usable for insert mode and for clamp mode

Length mm	Item No.	Weight Kg
L=1050mm	EH5340001	18,8
S=450mm	EH5340002	8,0

All mounting hardware is included.

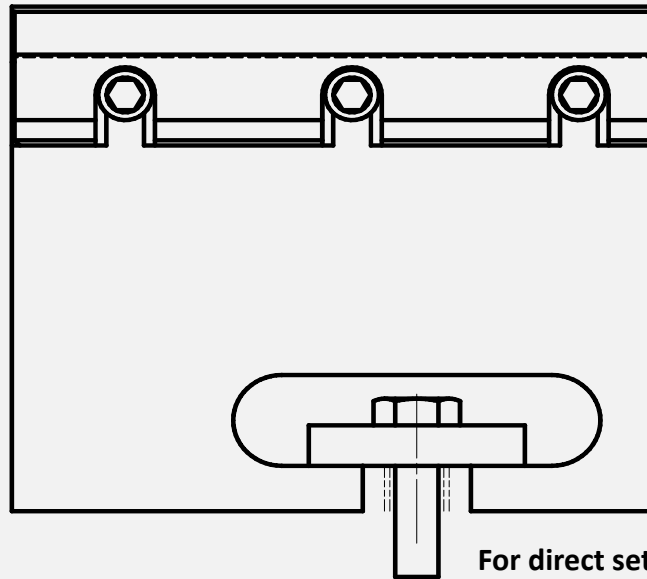

1000 kN/m

For direct setup on lower beam



Support for Die Holder 5340

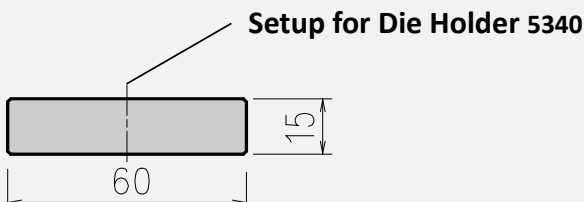

Length mm	Item No.	Weight Kg
L=1050mm	EH5340011	7,4
S=450mm	EH5340012	3,2

Die Holder 5330

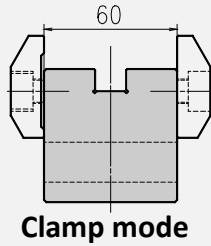
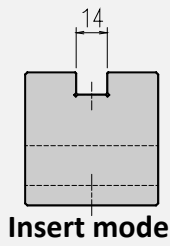
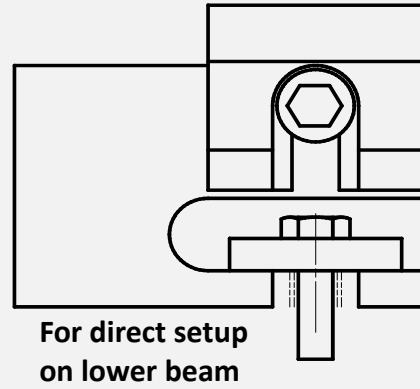
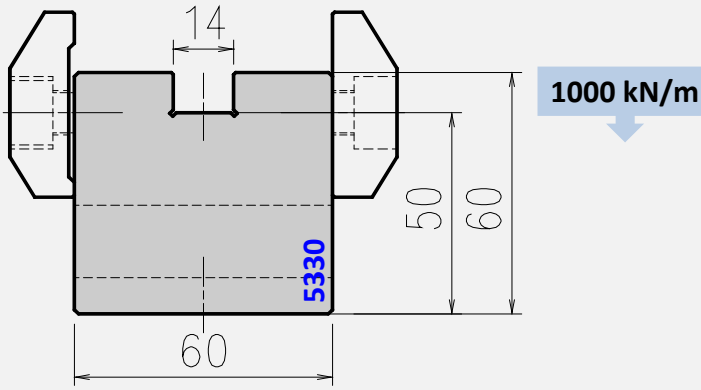

Length mm	Item No.	Weight Kg
L=1050mm	EH5330001	32,3
S=450mm	EH5330002	13,5

All mounting hardware is included.



Insert adaptor for polycarbonate dies (V4 to V12)

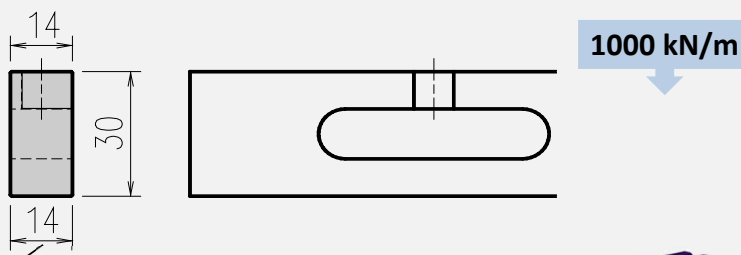

Length mm	Item No.	Weight Kg
L=834mm	EH3300011	2,5
S=414mm	EH3300012	1,2

All mounting hardware for polycarbonate dies is included.

Dimension for insert mode

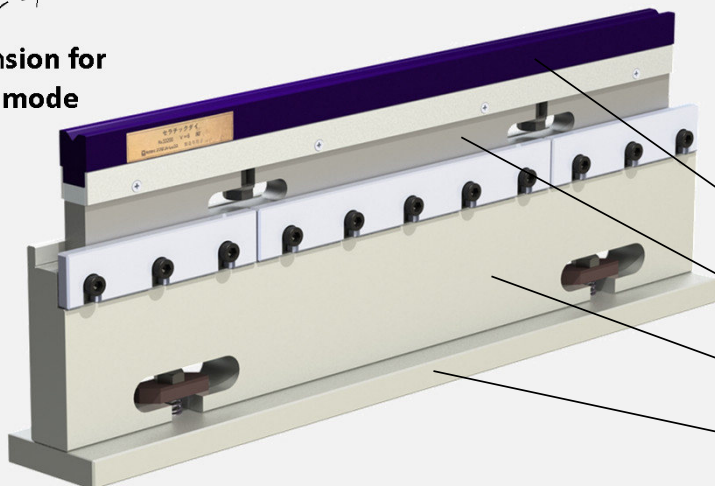

Polycarbonate Die DX 334002

Insert adaptor EH 3300012

Die Holder EH 5340002

Support for Die Holder EH 5340012

Die Holder 0550

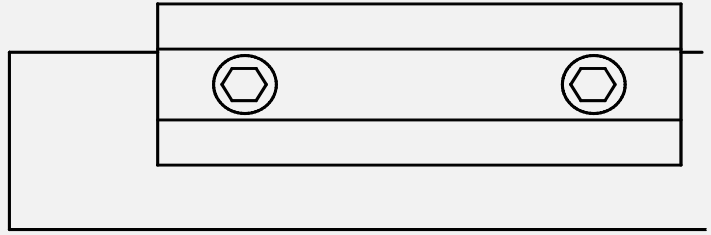
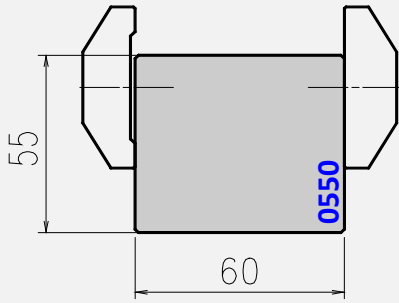

Length mm	Item No.	Weight Kg
L=835mm	EH0550001	25,8
S=415mm	EH0550002	13,5

Die Holder 0500

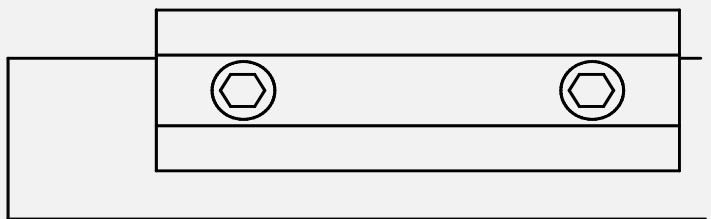
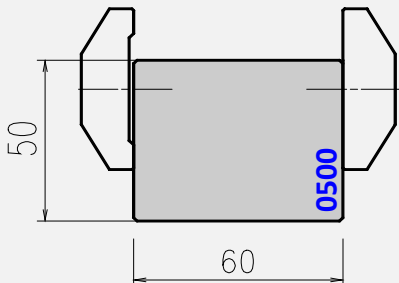

Length mm	Item No.	Weight Kg
L=835mm	EH0500001	23,8
S=415mm	EH0500002	12,5

Die Holder for 2V reversible dies

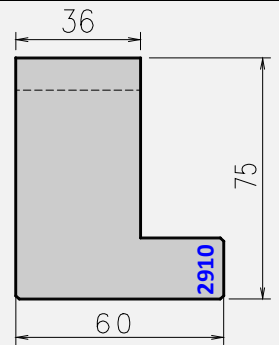
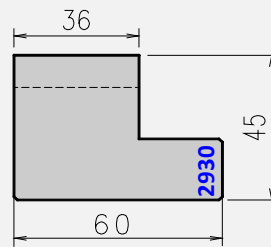
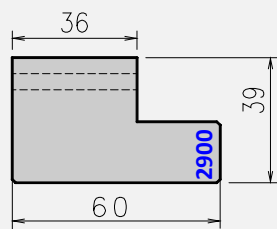

Length mm	H39	Weight Kg
	Item No.	
L=830mm	EH2900001	10,8
S=412mm	EH2900002	5,4

Item No.	Weight Kg
EH2930001	12,3
EH2930002	6,1

Item No.	Weight Kg
EH2910001	17,6
EH2910002	8,8

Die Holder for 2V reversible dies

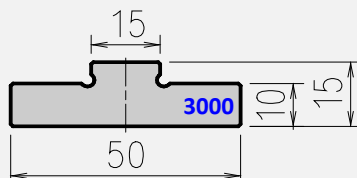

Length mm	Item No.	Weight Kg
L=835mm	EH3000001	3,8
S=415mm	EH3000002	1,9

Punch Holder SGRIP DUAL or SINGLE

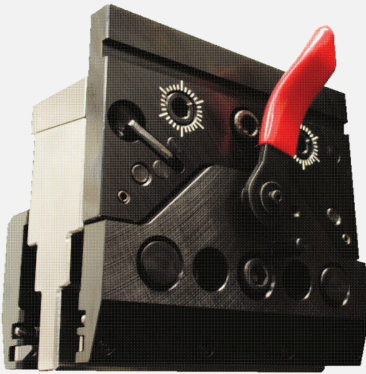
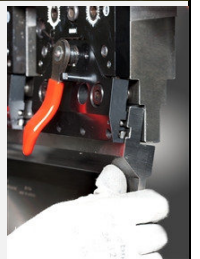
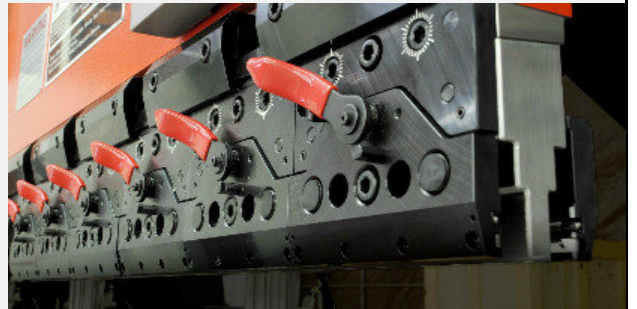
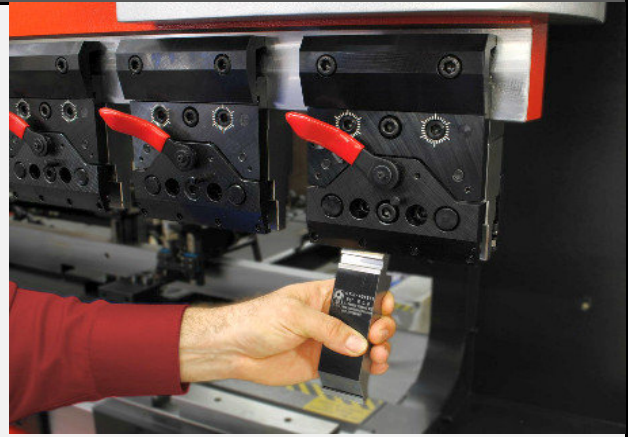
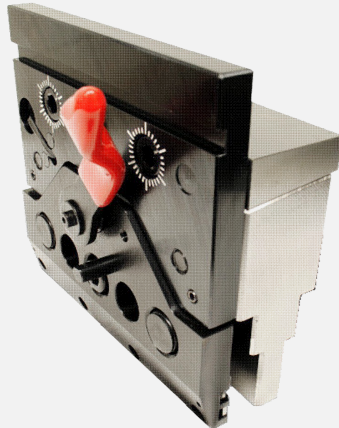
DUAL

SINGLE

Note:

- Tonnage: 1000 kN/m
- Effective Height: 120mm
- Front loading, unloading possible
- Adjustment wedge allows next to each other location

	Length mm	Item No.	Weight Kg
DUAL	150	DX903200	7,5
SINGLE	150	DX903100	6,3

Punch Holder AGRIP-M DUAL

Note:

- Tonnage: 1000 kN/m
- Effective Height: 120mm
- Front loading, unloading possible
- Adjustment wedge allows next to each other location
- Accurate clamping, positioning and alignment

Length mm	Item No.	Weight Kg
150	DX905200	7,5

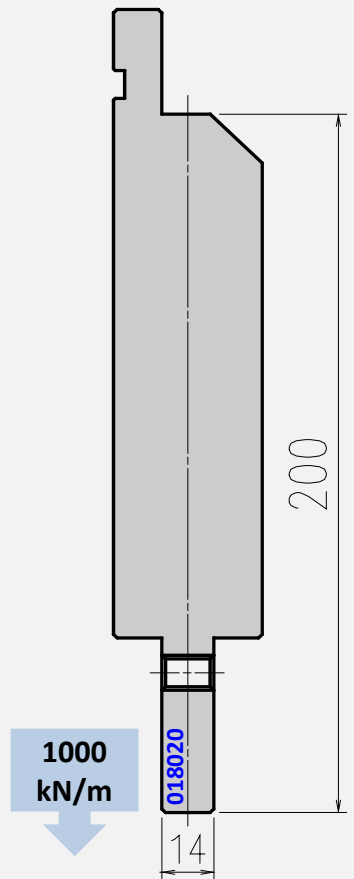
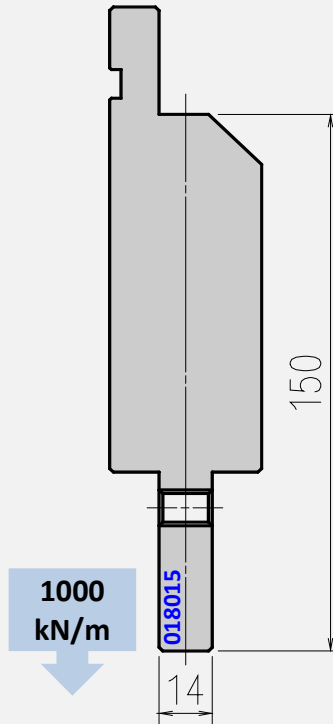
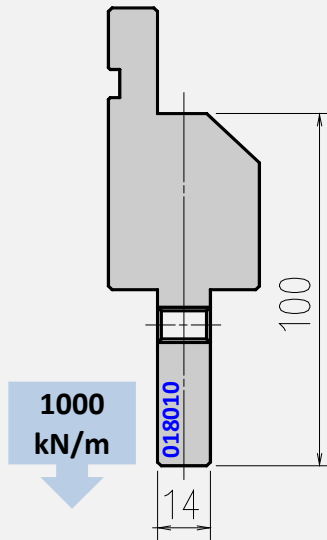
Distance piece 100
Distance piece 150
Distance piece 200

Note: Clamps are not included.

Length mm	Item No.	Weight Kg
150	EH0180100	3,5

Item No.	Weight Kg
EH0180150	5,9

Item No.	Weight Kg
EH0180200	8,5

Narrow Punch Holder 913

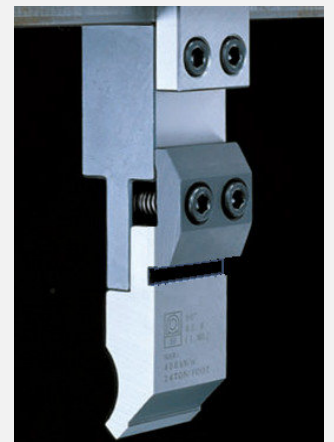
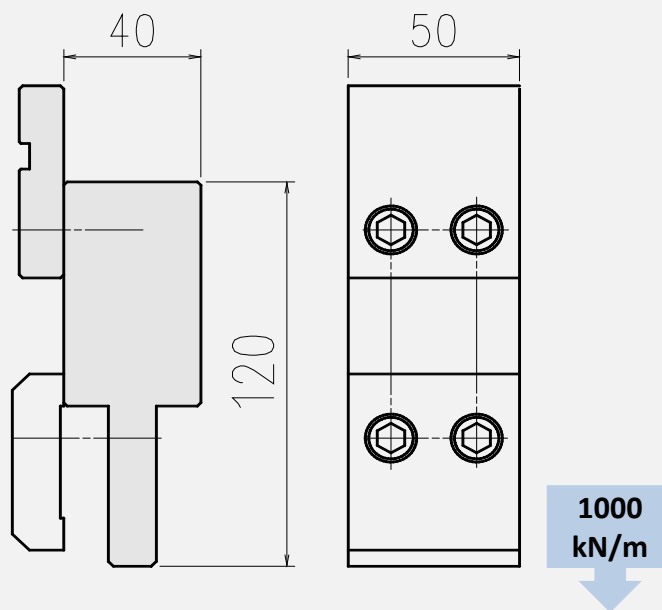

Length mm	Item No.	Weight Kg
50	AC913000	3,0

Punch Holder 0150

Punch Holder 0160

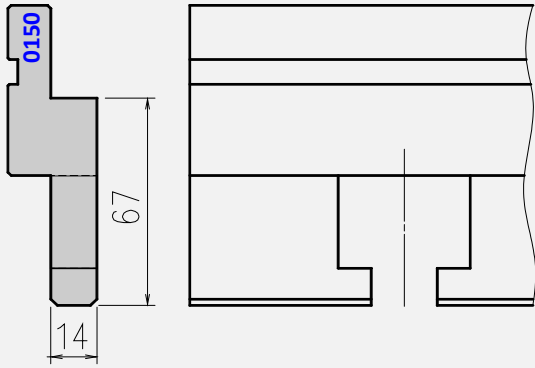

1000
kN/m

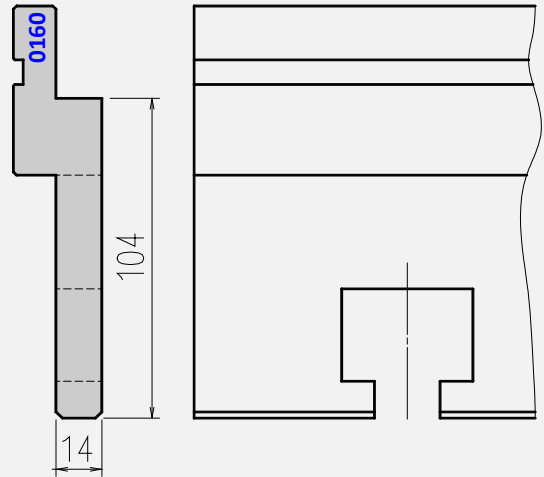

1000
kN/m



Holder 0150 replaces old holder 15

Length mm	Item No.	Weight Kg
830	EH0150001	9,8
412	EH0150002	4,9

Length mm	Item No.	Weight Kg
830	EH0160001	13,3
412	EH0160002	6,6

Deep bend Punch Holder

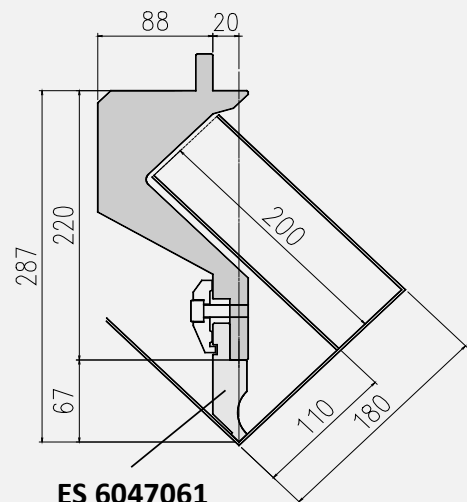
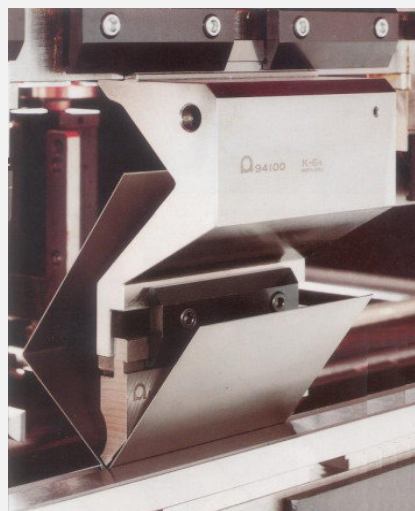
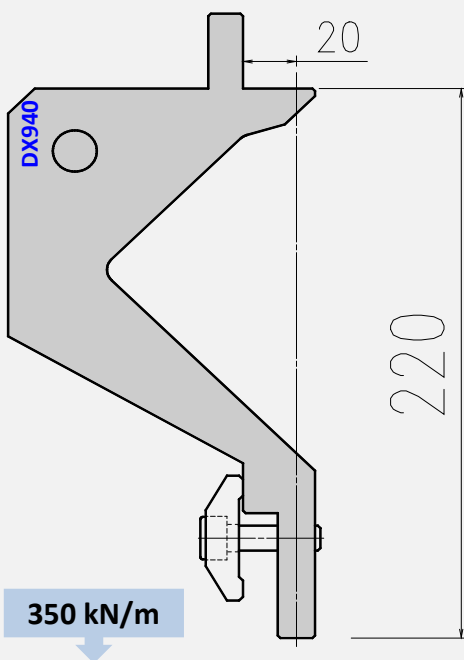

ES 6047061

Length mm	Item No.	Weight Kg
200	DX940000	18,0

Safety groove clamps
available from stock :
Item No. 961000



Super Multi II

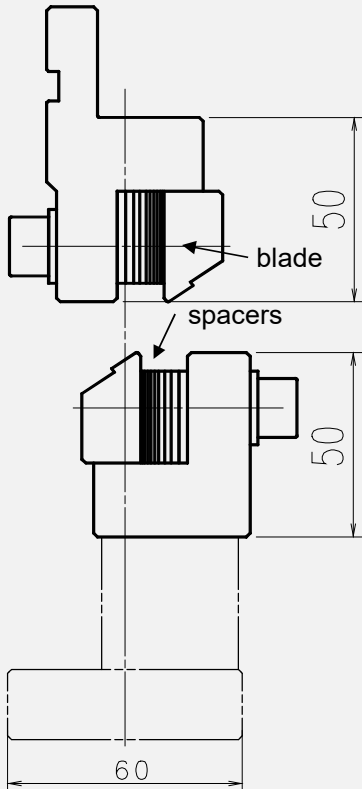

1000 kN/m

A variety of offset sizes in one tool !

Super multi tool-set is a versatile bending tool that achieves a variety of offset bendings by changing tooling offset in accordance with the spacer thickness.

- Sectionalized blade available
- Max. material thickness :
 - 2,3 mm (mild steel)
 - 1,5 mm (stainless)
 - 3,0 mm (Al)
- Tool Offset range $H_{\text{tool}} = 1,79 - 7,81$ mm
- Due to the air bending method, product offset value is differing from tool offset, so please ask for charts.

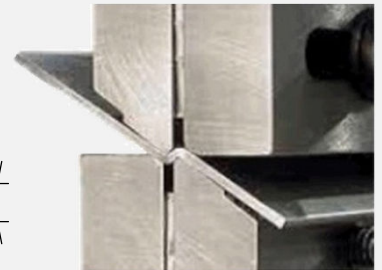
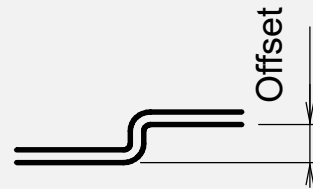

L-Set = 835 mm including all 835 mm spacers



S-Set = 415 mm including all 415 mm spacers

Length mm	Item No.	Wt. Kg
835	S20021	35,4
415	S20022	17,6

Replacement blades for Super Multi II

Blade 835 mm : S2B021



Blade 415 mm : S2B022



Sectional Blade 415 mm (10, 15, 20, 40, 50, 100, 180) : S2B802



Length mm	Item No.	Wt. Kg
835	S2B021	2,6
415	S2B022	1,3
415 sec.	S2B802	1,3

Alignement jig for Super Multi II

guarantee perfect alignment and finest adjustments in all planes (Set includes 2 pcs.)

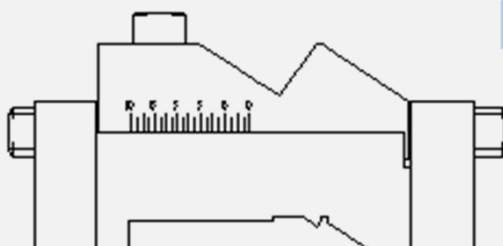

20 kN/m

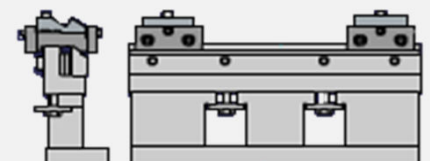

Item No.	Wt. Kg
S20030	3,0

90° Side gauge 930



Note:

- Max. 60 mm die width
- Min. 13 mm die width
- Left-gauging or right-gauging
- Fixation on die

Item No.	Weight [Kg]
AC930000	2,0

90° Side gauge for 1V dies 939

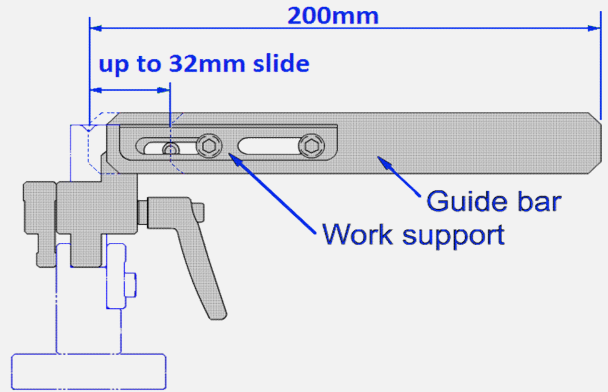

Note:

- Left-gauging or right-gauging
- Fixation on die holder

Item No.	Weight [Kg]
AC939000	1,0

Angle adjustable side gauge 932

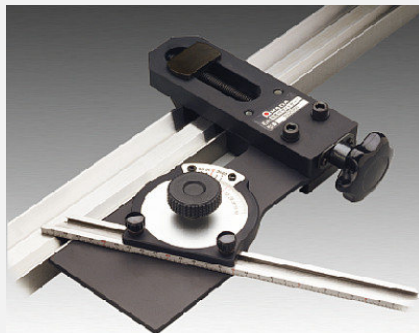
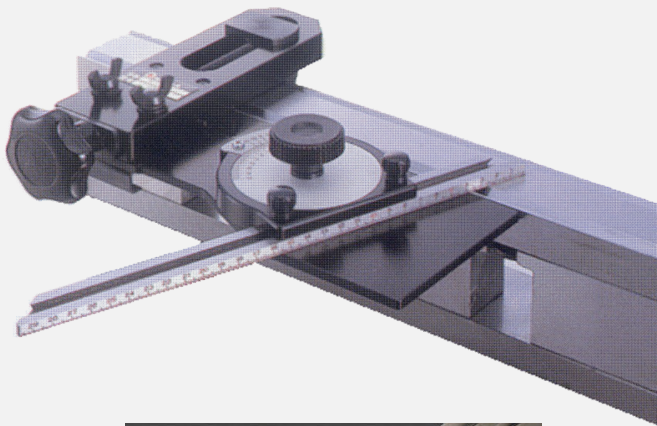

Note:

- Fixation on die (1V or 2V dies)
- Left-gauging or right-gauging
- Indexable within 100° (at 5' increments)

Item No.	Weight [Kg]
AC932000	2,6

Digital angle gauge 9351

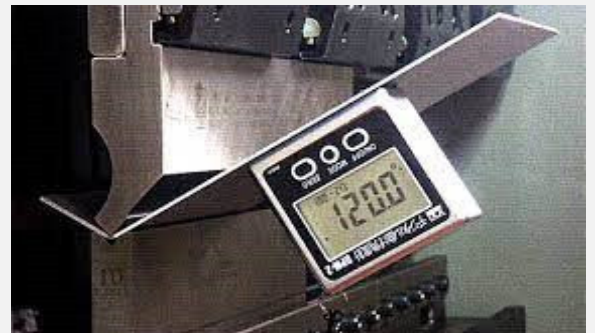

Note:

- Shows bending angle in real time
- Resolution of 0,1°
- Use only with magnetisable sheet metal

Item No.	Weight [Kg]
AC935100	0,2

Closing tool

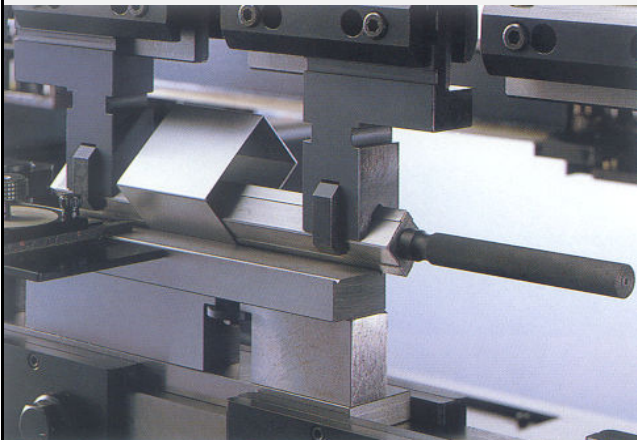
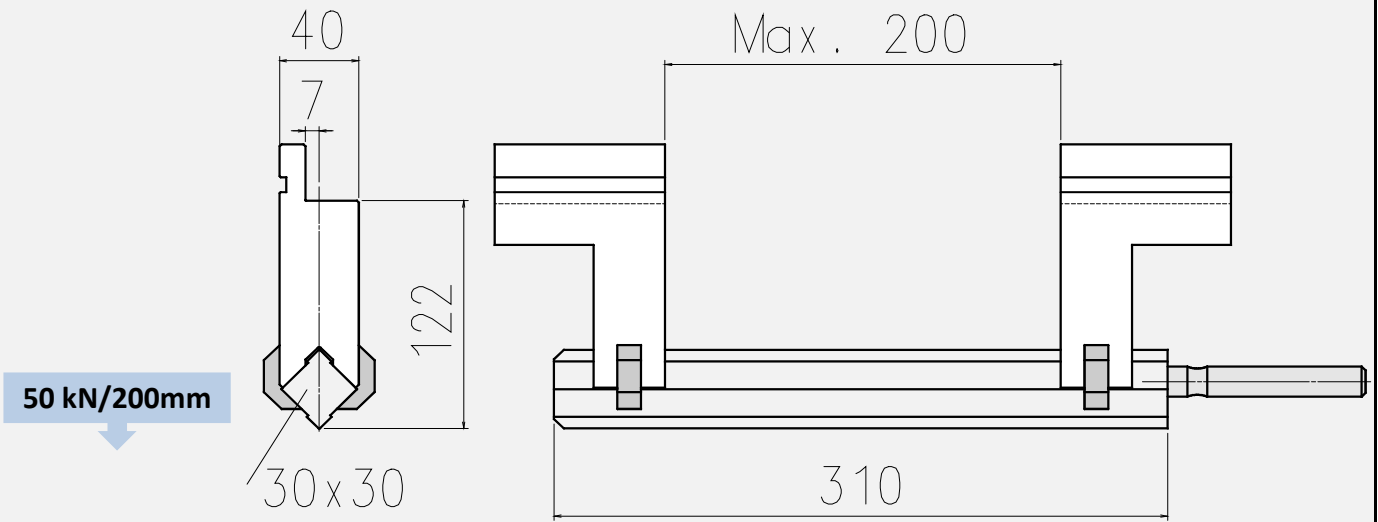

Guidance for thickness and V opening by tool gap:

Tool gap	Mild steel	Stainless steel	Aluminum
100mm	t ≤ 4,5 ≥ V40	t ≤ 2,5 ≥ V25	t ≤ 5,0 ≥ V32
150mm	t ≤ 2,3 > V16	t ≤ 1,5 ≥ V12	t ≤ 3,0 ≥ V18
200mm	t ≤ 1,6 > V10	t ≤ 0,8 ≥ V6	t ≤ 2,0 ≥ V10

Tool angle	Radius mm	Item No.	Weight Kg
88°	R0,6	C00010	6,0

Note:

- Please minimize tool gap, according to sheet part

"BendingTool"

The bending app by Amada

Using BendingTool you can quickly calculate on the spot:

- Press force
- Press force table
- Bend deduction
- Sheet gauge conversion
- Weight of sheet
- Box bending parameters
- Return bend graphs

The BendingTool is available free for iOS in the app store.

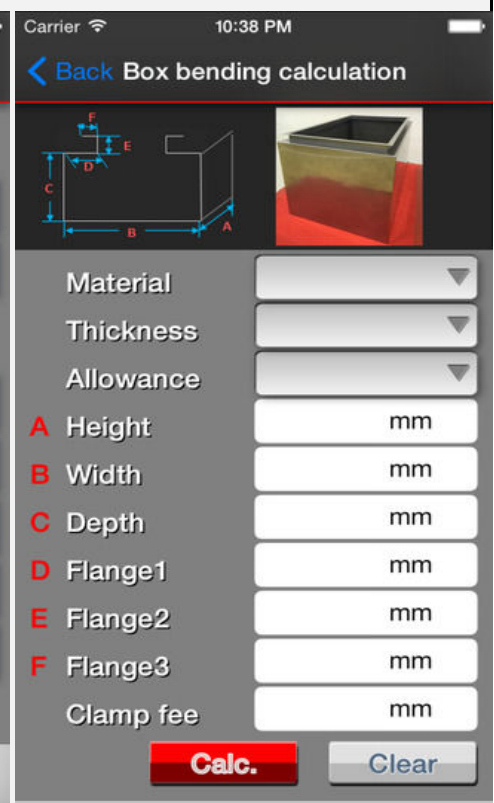

Type VLMBN

Minimum die angle	30°
V-Opening	adjust. each 10mm ca. V25 - V125
Sheet thickness	3 - 15 mm
Shoulder Radius	R8 mm
Die length	500 mm
Max. allowable tonnage	1250 kN/m
Hardness Radius inserts	HRC 60
Spacers:	5; 10; 15; 20

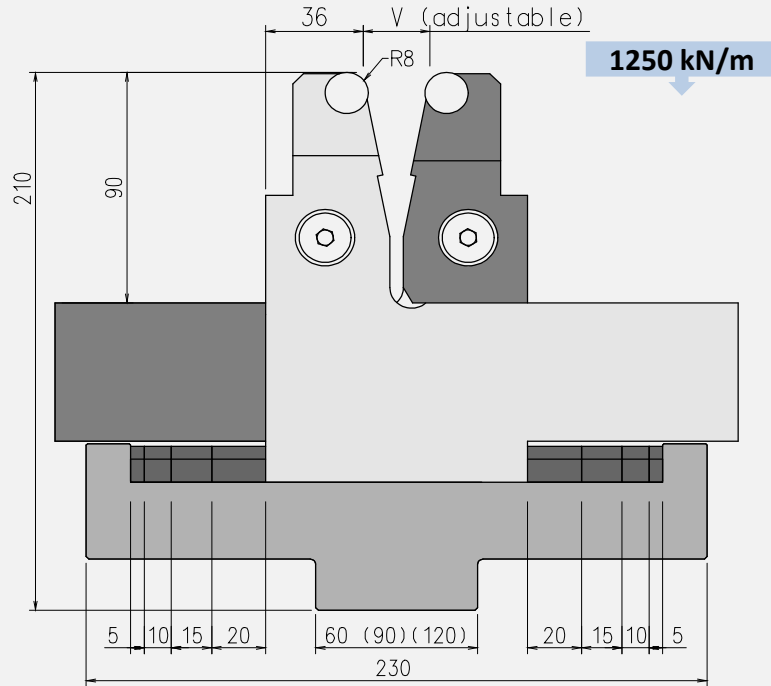

	for 60mm beam	for 90mm beam	for 120mm beam			
	Item No.	Weight Kg	Item No.	Weight Kg	Item No.	Weight Kg
Set	BN1-500S	96	BN2-500S	99	BN3-500S	99
only Holder	BN1-500H	33	BN2-500H	36	BN3-500H	36

	Item No.	Weight Kg
only Die	BN 500D	58
only spacers	BN-500I	5,3
only strip	ACBN150	0,1

Type VLMDN

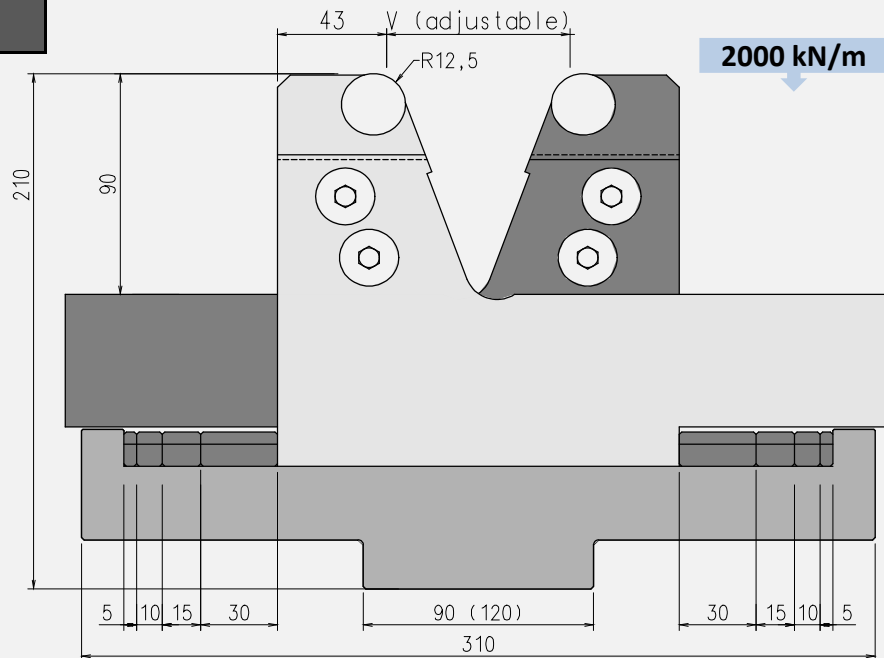
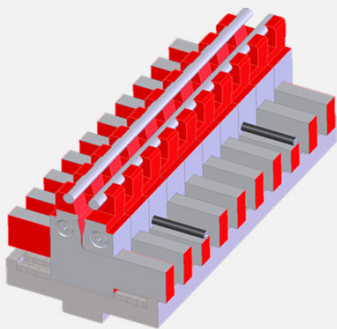
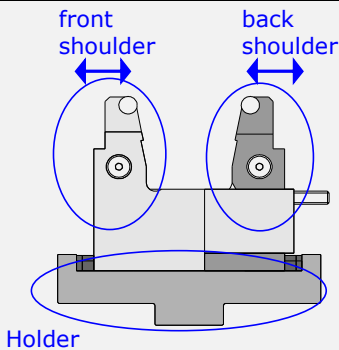

	for 90mm beam	for 120mm beam		
	Item No.	Weight Kg	Item No.	Weight Kg
Set	DN2-500S	137,1	DN3-500S	44,6
only Holder	DN2-500H	44,6	DN3-500H	44,6

	Item No.	Weight Kg
only Die	DN 500D	86
only spacers	DN-500I	6,4
only strip	ACDN150	0,1

Minimum die angle	60°
V-Opening	adjust. each 10mm ca. V70 - V190
Sheet thickness	3 - 20 mm
Shoulder Radius	R12,5 mm
Die length	500 mm
Max. allowable tonnage	2000 kN/m
Hardness Radius inserts	HRC 60
Spacers:	5; 10; 15; 30

WingBend bending features

- very small flanges
- wide range of materials using the same die
- small bend radii
- bends closer to holes
- forming oblique flanges
- less scratches
- scratch-free bending for film protected sheet metal

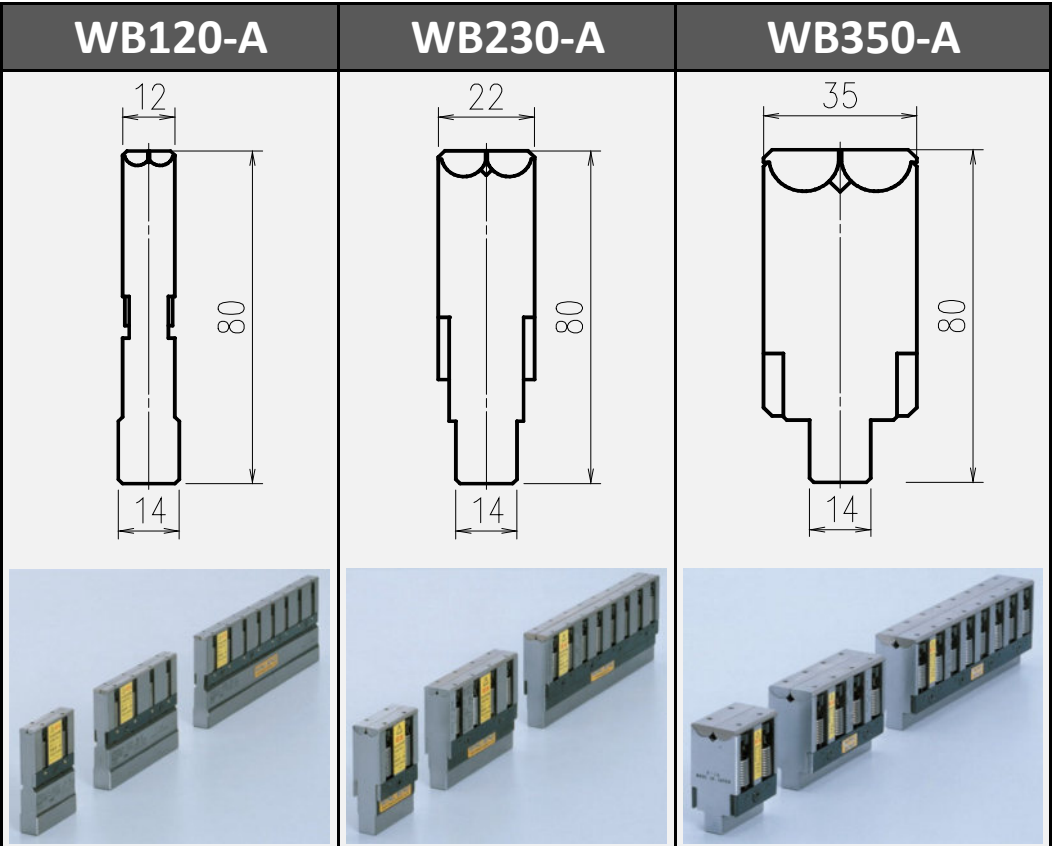

Equivalent die opening		up to V6	up to V10	up to V15
Mat. thickness	Mild steel	0,5 ~ 1,2	0,5 ~ 2,3	1,0 ~ 3,2
	Stainless steel	0,5 ~ 1,0	0,5 ~ 2,0	1,0 ~ 3,0
	Aluminium	0,5 ~ 1,0	0,5 ~ 2,0	1,0 ~ 3,0
Min. angle		80°	80°	80°
Tonnage		1000 kN/m	1000 kN/m	1000 kN/m
Code and weight per tool length	50mm	70120A (0,4Kg)	70230A (0,6Kg)	70350A (0,9Kg)
	100mm	70120B (0,7Kg)	70230B (1,2Kg)	70350B (1,5Kg)
	200mm	70120C (1,4Kg)	70230C (2,3Kg)	70350C (3Kg)

Tonnage and process data:

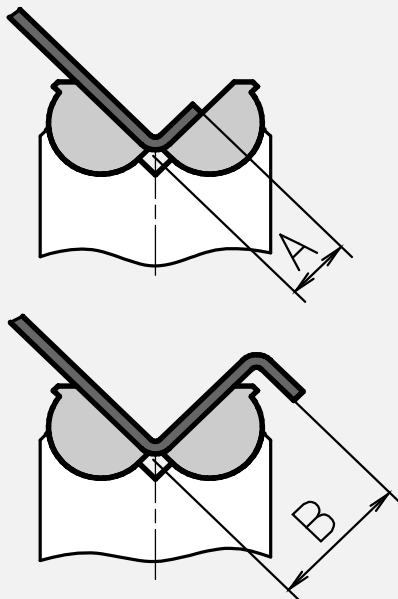

How to read table data:

Tonnage (kN/m)			
A	Min. flange length (mm)		B
		Min. offset value (mm)	

t (mm)	WB120-A		WB230-A		WB350-A	
0,5	50		50		40	
	3,6	7,3	5,7	12,2	8,1	19,3
0,8	100		70		50	
	3,8	7,4	5,9	12,4	8,4	19,5
1	150		80		60	
	4,0	7,4	6,1	12,6	8,6	19,7
1,2	240		110		70	
	4,1	7,5	6,2	12,7	8,8	19,9
1,6			200		140	
			6,4	12,9	9,0	20,2
2			300		200	
			6,6	13,0	9,4	20,4
2,3			400		260	
			6,8	13,2	9,6	20,6
2,6					340	
					9,8	20,8
3,2					510	
					10,2	21,0

Note:

- this chart is showing bending data for mild steel
- bending operation in the dark range is not recommended
- Min. flange length and min. offset value are reference values

Punch Type 831 H200 30°-R0,6		Punch Type 846 H200_W110 86°-R0,6		Punch Type 841 H200_W55 60°-R0,6		Punch Type 841 H200_W95 60°-R0,6	
Item No. SE8310012		Item No. SE8460012		Item No. SE8410012		Item No. SE8410022	
Tool length	415	Tool length	415	Tool length	415	Tool length	415
Weight (Kg)	12,2	Weight (Kg)	27,2	Weight (Kg)	16,8	Weight (Kg)	22,4

Punch Type 804 H220 86°-R0,6		Punch Type 846 H220_W55 86°-R0,6		Punch Type 846 H220_W95 86°-R0,6		Semistandard dies	
Item No. SE8040012		Item No. SE8460022		Item No. SE8460032		Item No. ---	
Tool length	415	Tool length	415	Tool length	415	Tool length	835
Weight (Kg)	14,9	Weight (Kg)	19,4	Weight (Kg)	25,9	Weight (Kg)	---

- All punches with 1000 N/mm² body strength and 54-58 HRC tip hardness
- According to your requirements please ask for special tip radius, special sectionalized lengths, special ear shapes (considering the reduced tonnage capacity)
- Without non corrosive coating on punch body
- See chapter "Tables and Graphs" for return bend area details

Large-radius bending

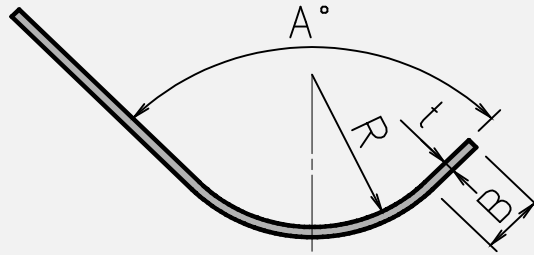
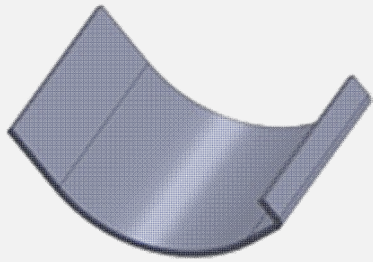

Note:

- please check the option to use step-bending process
- for mild steel ($3t < R < 30t$), R value will vary around $\pm 5\%$
- for $R \geq 30t$ less accuracy should be considered
- for $B < 10t$ air bending is not recommended

Using air-bending tools

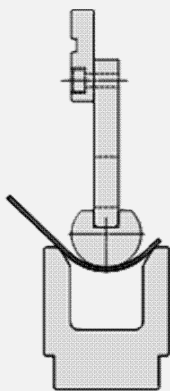

Using counterpressure

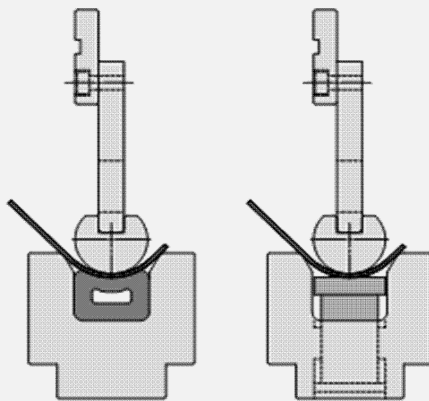

Using coining tools

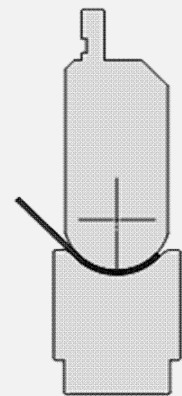

Offset bending

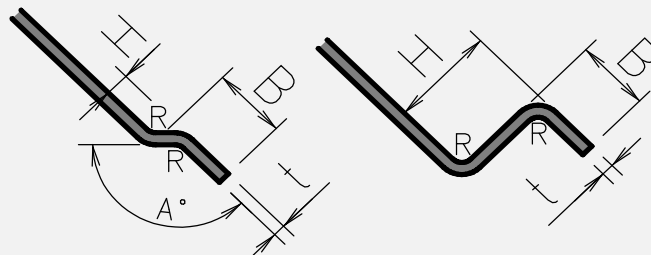
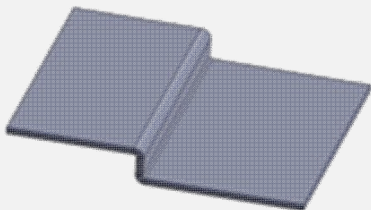

Note:

- please check the option to use standard offset tools
- best results for $R \approx 0,3H$; $B = 1,4H + 5\text{mm}$; $H < 12\text{mm}$ (mild steel)
- H results will vary around $\pm 0,2\text{mm}$
- for $H < 2,8t$ less accuracy

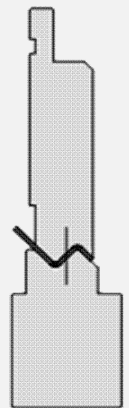

Hat bending

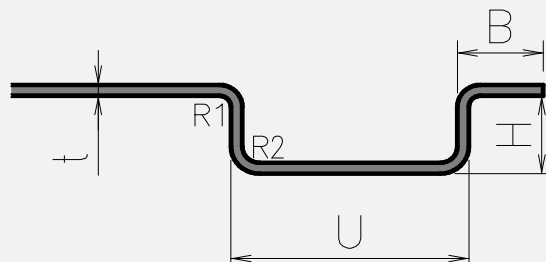
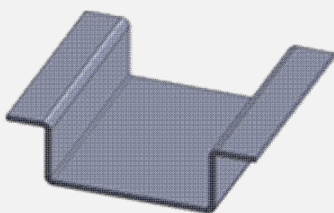

Note:

- best results for $R1 \approx t$; $R2 \approx 2t$; $H \approx (5t \text{ bis } 15\text{mm})$ $U \approx (4t \text{ bis } 30\text{mm})$
- H and U results will vary around $\pm 0,2\text{mm}$
- for $B < 10t$ less accuracy

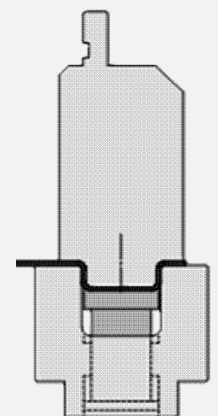

U bending

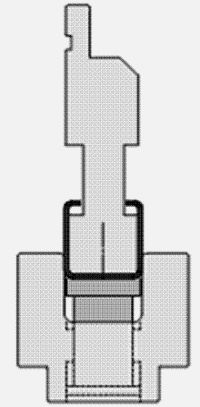
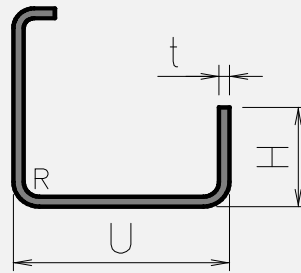
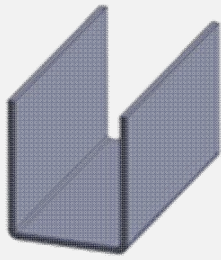

Notes:

- best results for $R \approx t$; $U \approx (4t \text{ bis } 30\text{mm})$
- U results will vary around $\pm 0,2\text{mm}$
- top side of the U shape could slightly open

Beading (longitudinal to the bending line)

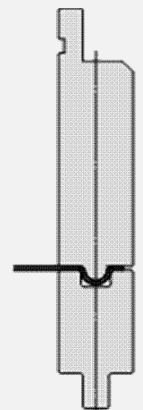
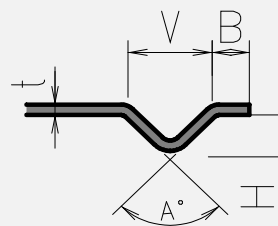
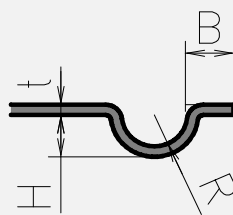
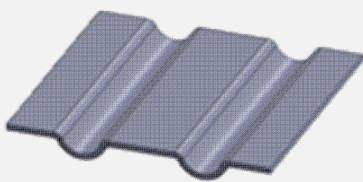

Note:

- best results for $R \approx (3t \text{ bis } 10\text{mm})$;
 $V \approx (4t \text{ bis } 30\text{mm})$ and $A > 60^\circ$ (mild steel)
- H results will vary around $\pm 0,2\text{mm}$
- for $B < 10t$ less accuracy

Beading (transversal to the bending line)

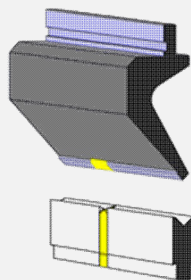

Needed data:

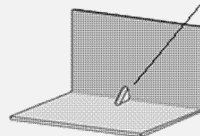
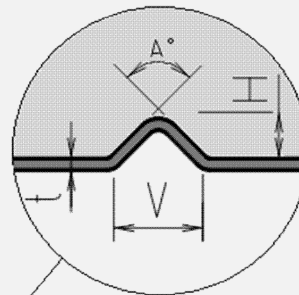

Flattening

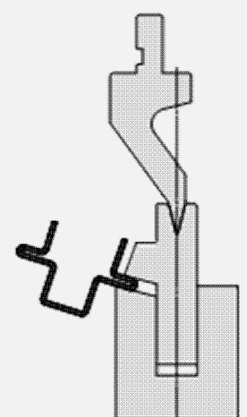
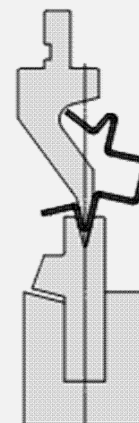
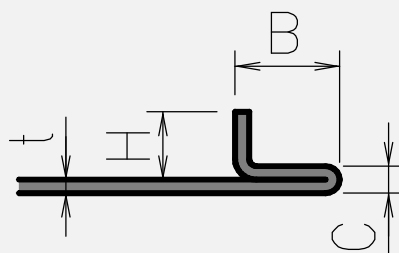
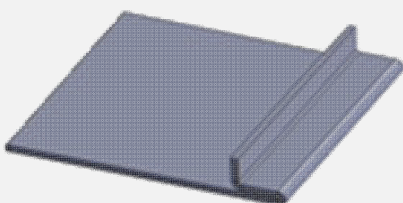

Note:

- for $C = 2t$ high bending force is required
- for more complex parts double-deck type tools are not possible
- higher flange of $H > B$ could cause tonnage problems

Determination of customized bending sequences

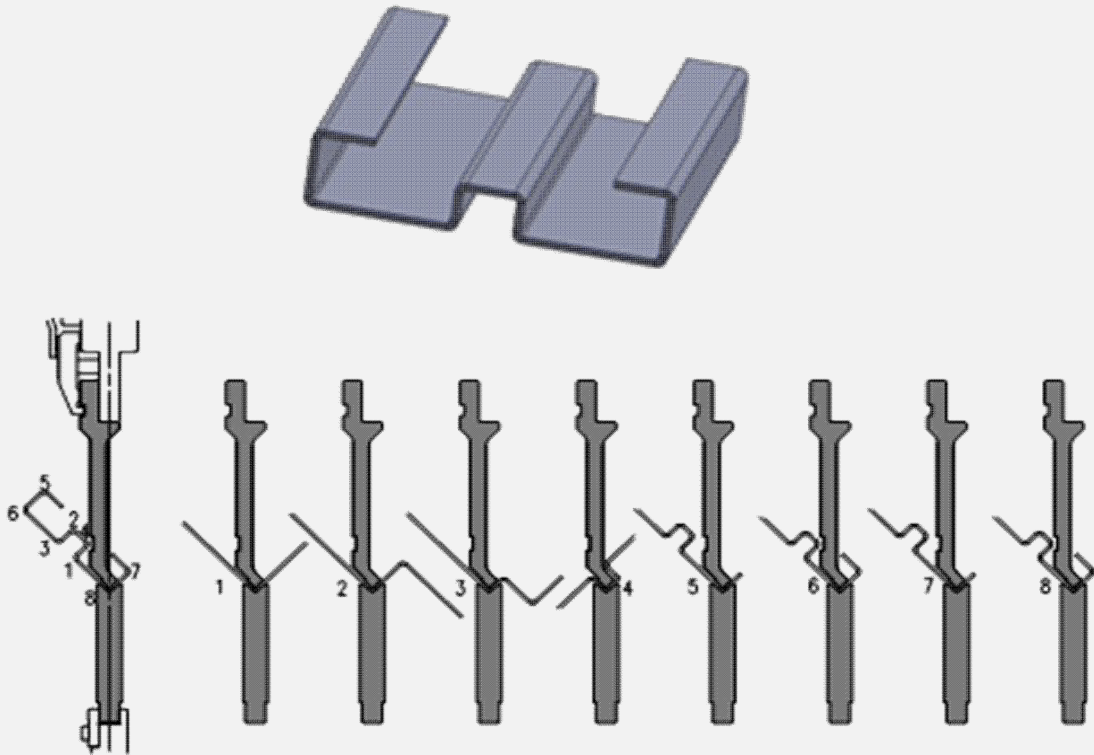

Conversion Adaptors

Amada offers adapting solutions for press brakes with Non-Amada style tooling. The advantage of these adaptors is the short and adjustable height in order to optimize open height of the press brake. For an offer, all Non-Amada dimensions are needed.

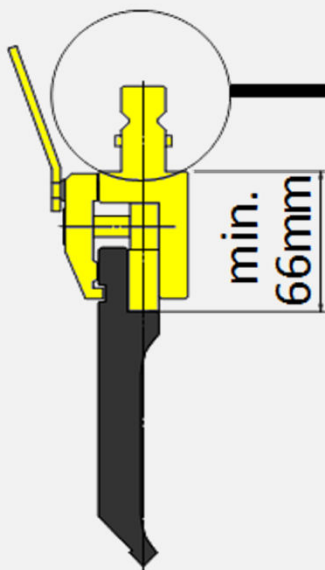

Height-adjustable adaptor for punches:

From **NON-AMADA** system
(Beyeler, LVD, Wila, ...)
to **AMADA**

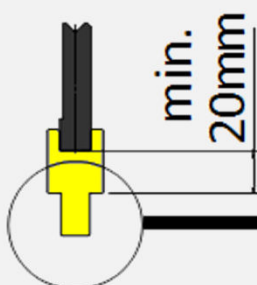

Adaptor for Dies:

From **NON-AMADA** system
(Beyeler, LVD, Wila, ...)
to **AMADA** (Insert, Reversible, Direct)



Tooling profile change for punches

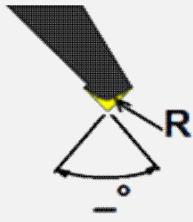

Modifications of the tool parameters

due to "throughhardened" quality, Amada tools have same hardness after modification (heat treatment is not necessary)

- Angle modifications (for sprinback compensations)
- Tip radius modifications
- Regrinding and repairing
- Modifications of the length or special section widths
- Special coatings against galling and special marking on request

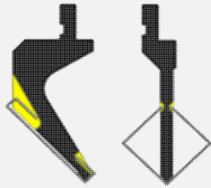

Modifications according to the shape of the sheet metal part

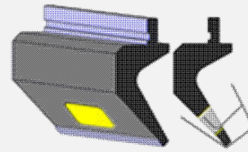

Modifications of the punch body for closed bending

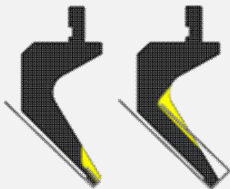

Due to highest strenght of the body, Amada tools can be modified much thinner than conventional tools

- Modifications for very thin U-shaped sheet metal parts
- Modifications for very close C-shaped sheet metal parts

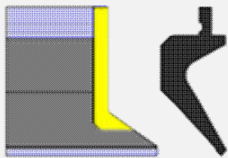

Modifications of the ear tool (length and profile)



Rulers with special radii

Tooling profile change for dies

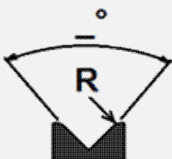

Modifications of the tool parameters

- Angle modifications (for sprinback compensations)
- Shoulder radius modifications (for less marks)
- Regrinding and repairing
- Modifications of the length or special section widths
- Special coatings against galling and special marking on request

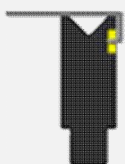

Modifications according to the shape of the sheet metal part

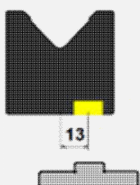

Adaptions for the reversible system



Adaptions for the insert system

RETURN BEND LIMIT GRAPH
PUNCH 804 (C804)

[← Back to index](#)

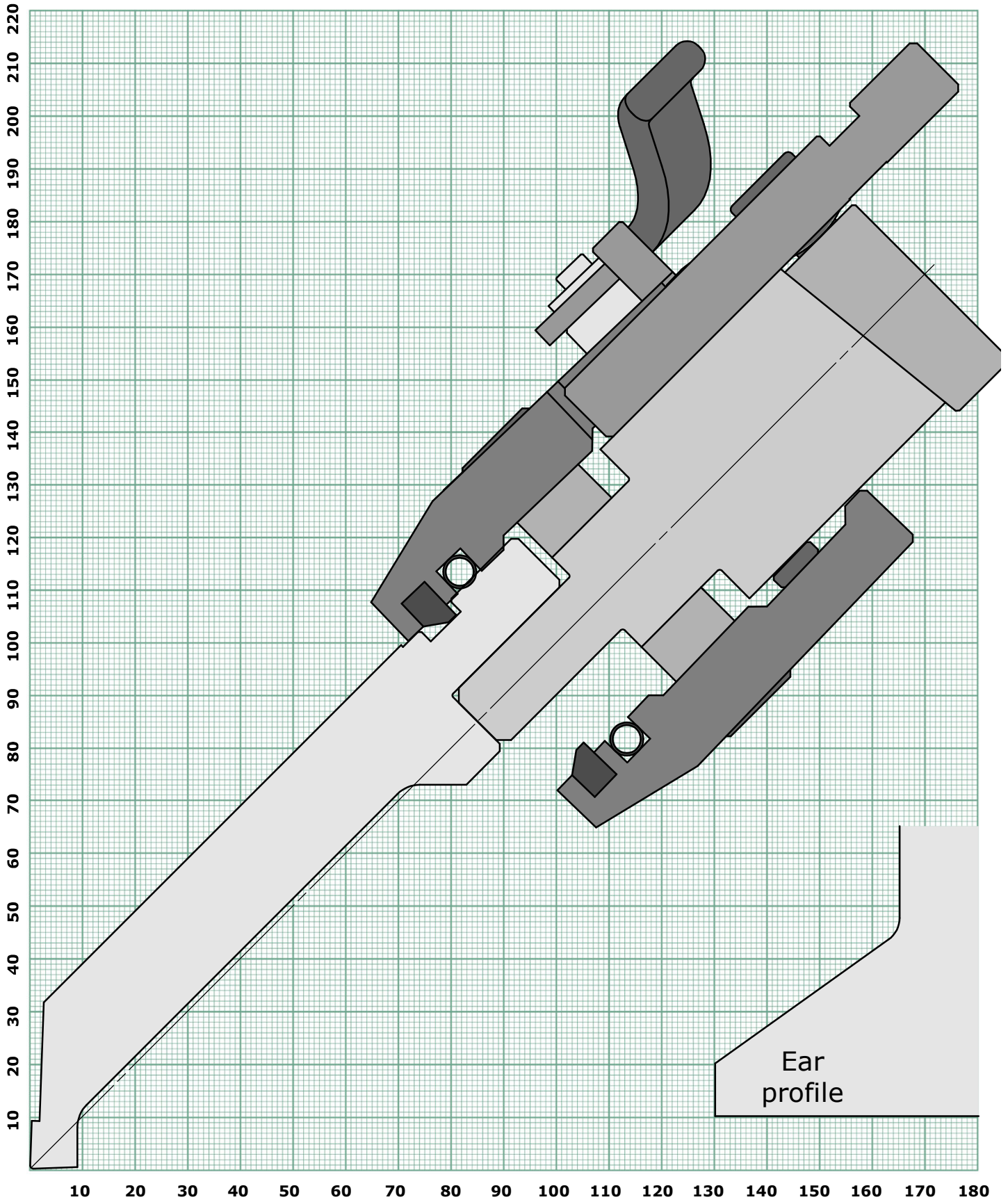

RETURN BEND LIMIT GRAPH
PUNCH 817 (C817)

[← Back to index](#)

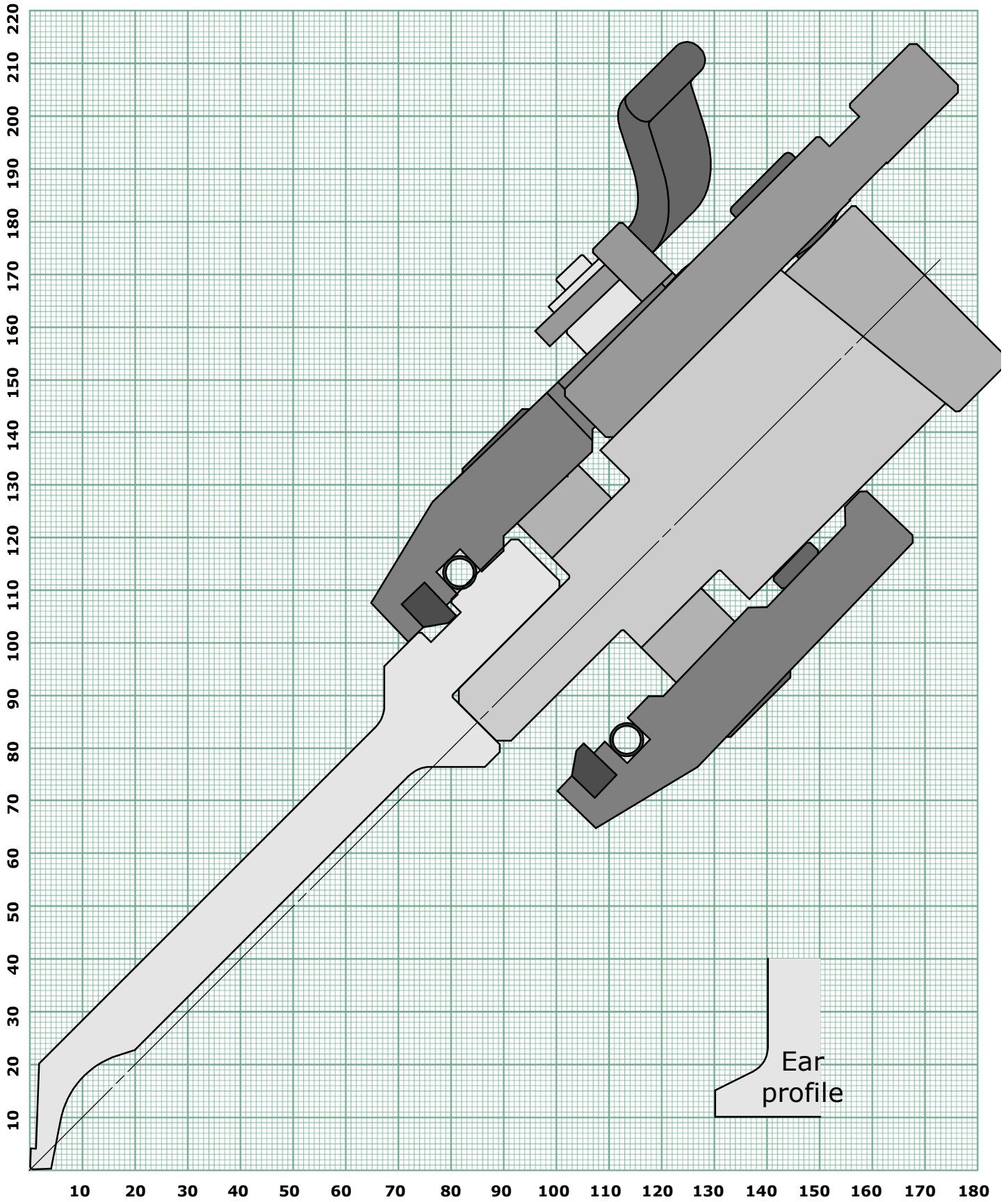

RETURN BEND LIMIT GRAPH
PUNCH 814 (C814)

[← Back to index](#)

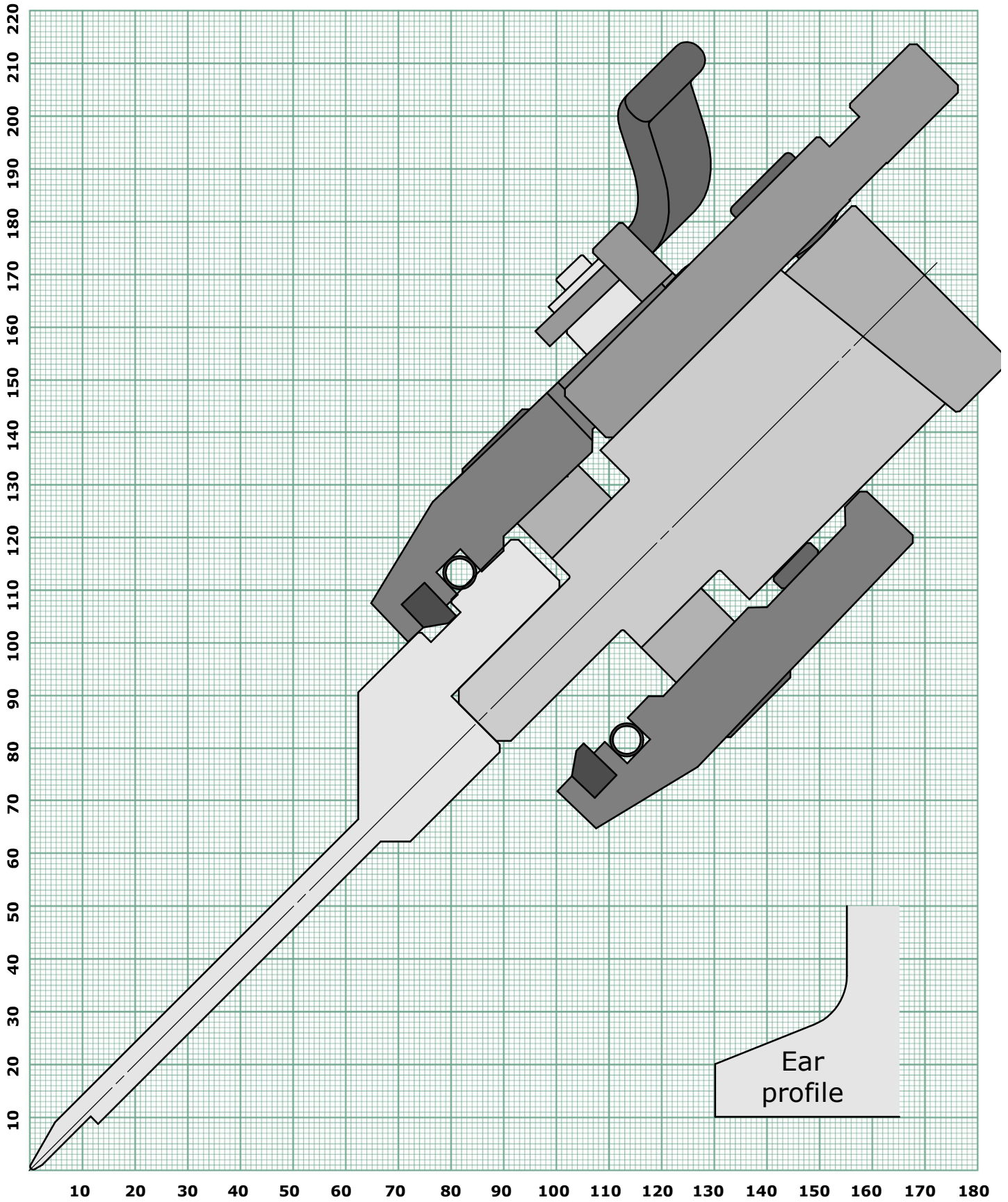

RETURN BEND LIMIT GRAPH
PUNCH 820 (C820)

[← Back to index](#)

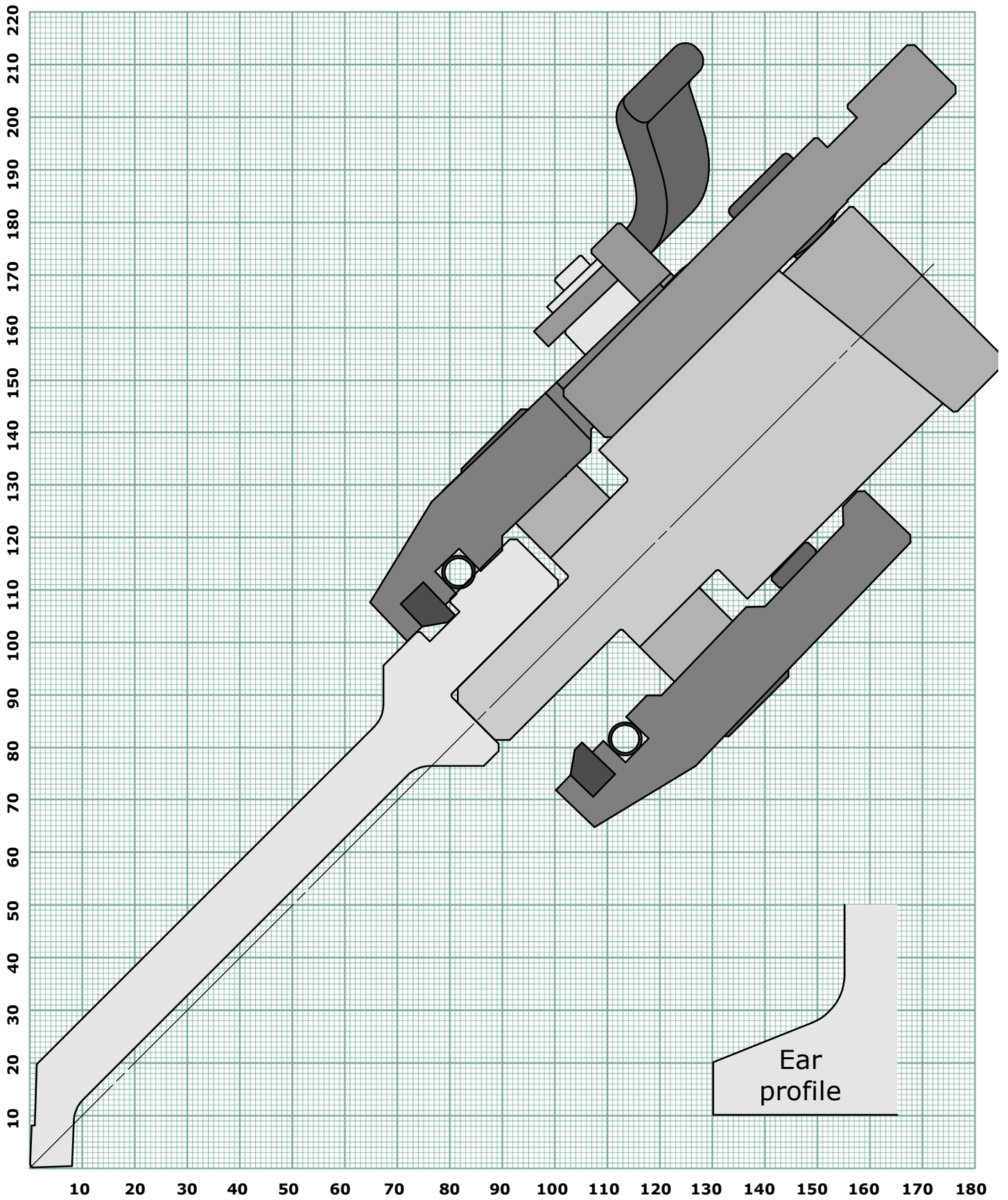

RETURN BEND LIMIT GRAPH
PUNCH 831-R0,6 (C831-R0,6)

[← Back to index](#)

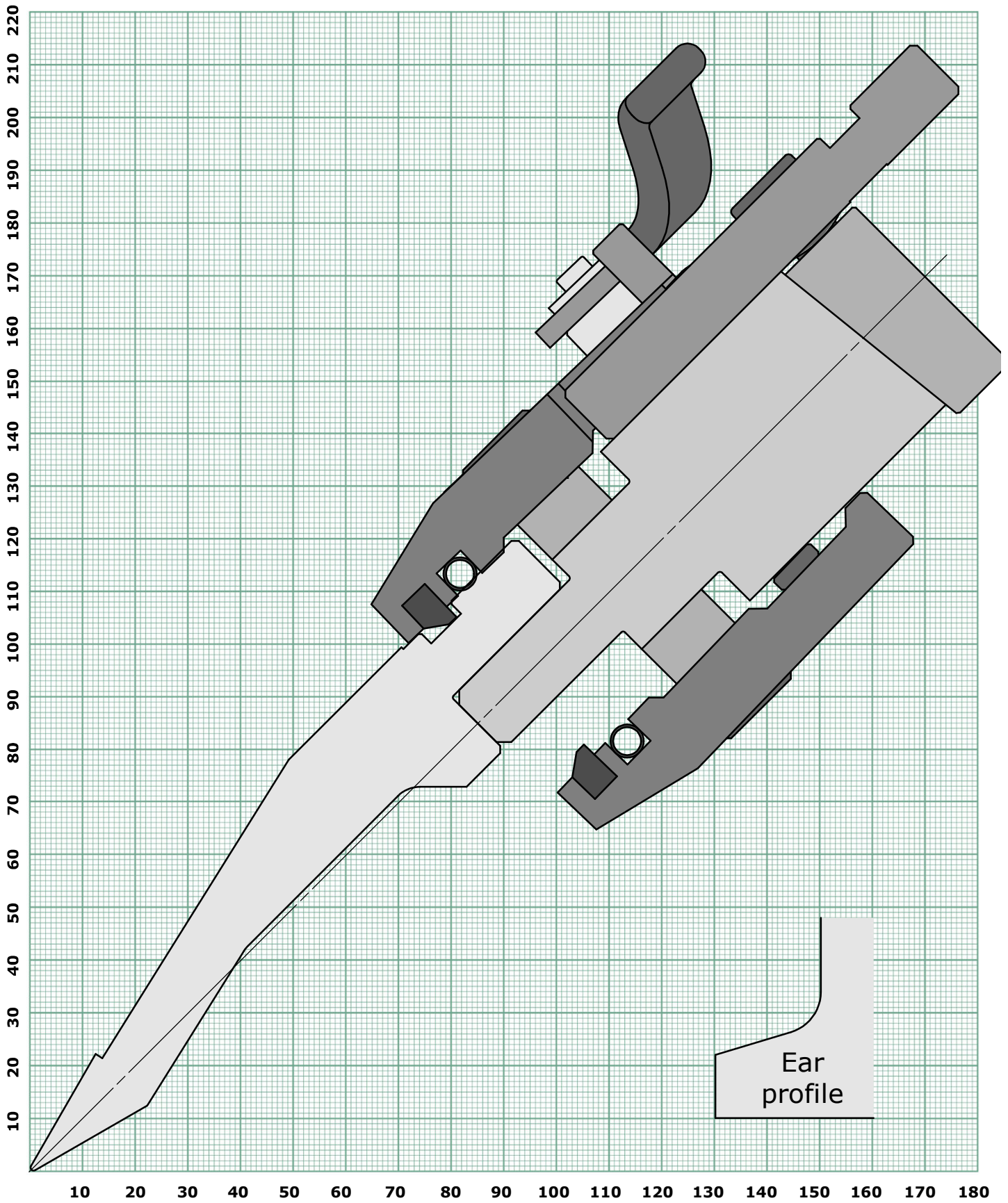

RETURN BEND LIMIT GRAPH
PUNCH 831-R3 (C831-R3)

[← Back to index](#)

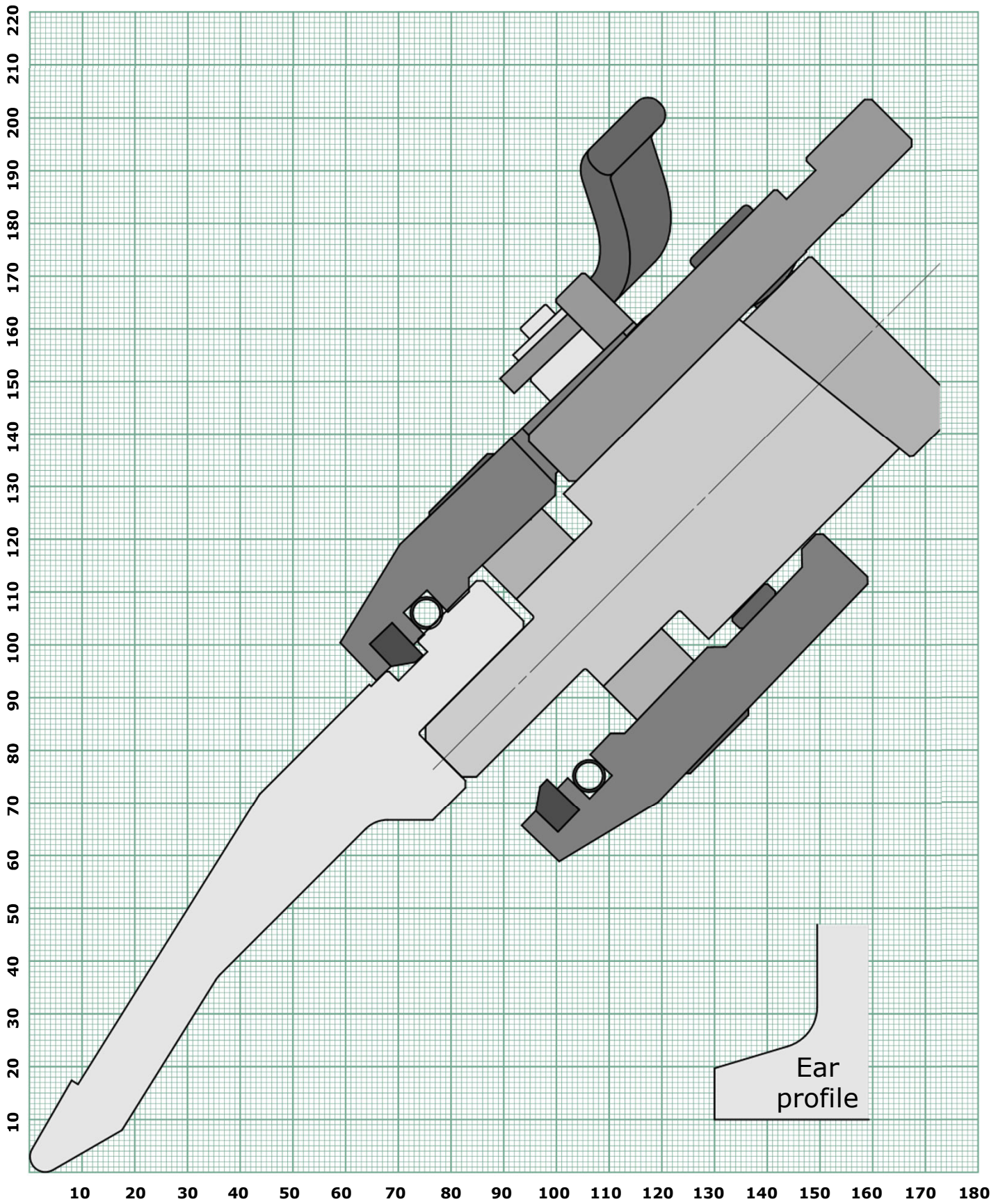

RETURN BEND LIMIT GRAPH
PUNCH 831-R4

[← Back to index](#)

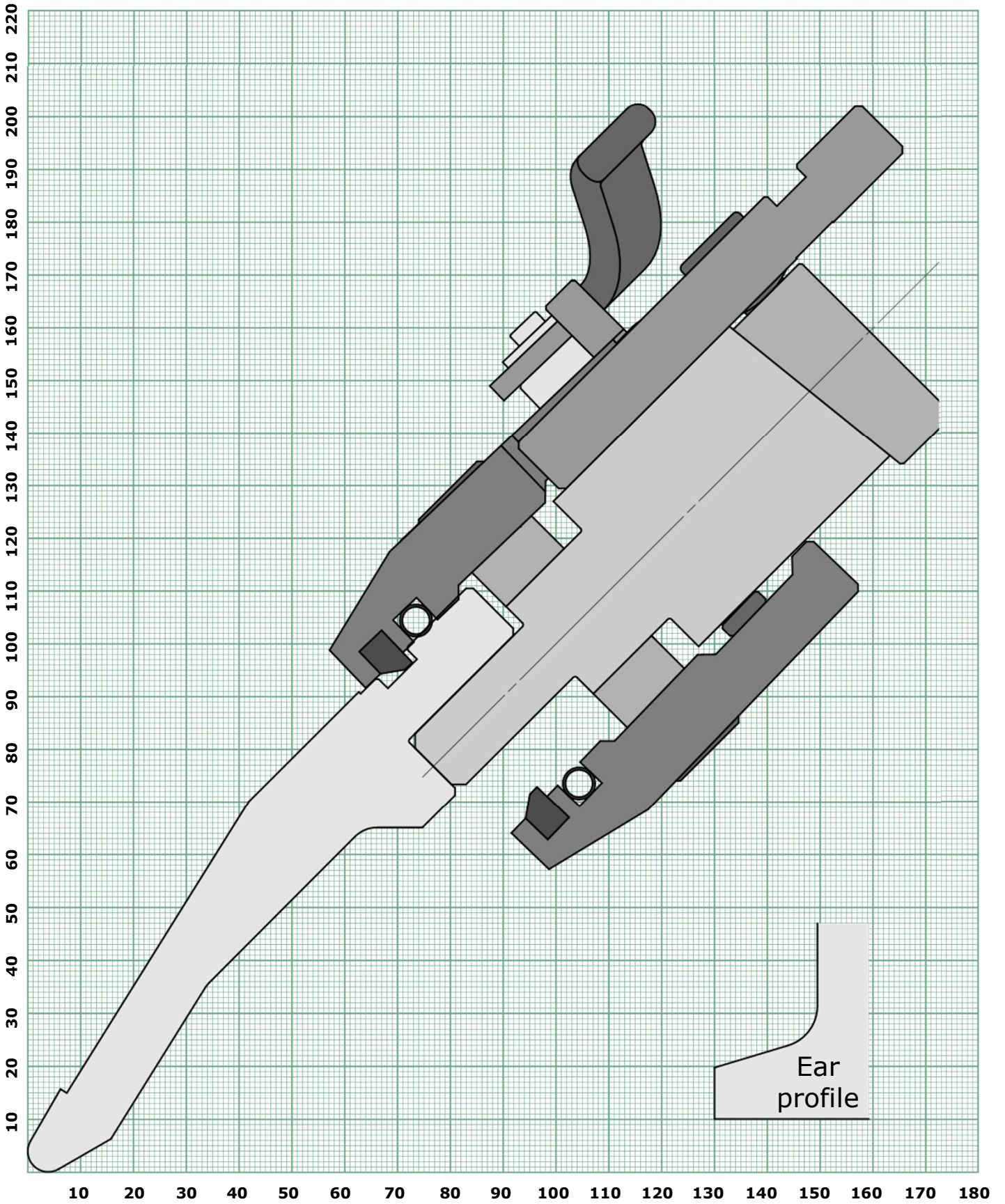

RETURN BEND LIMIT GRAPH
PUNCH 840

[← Back to index](#)

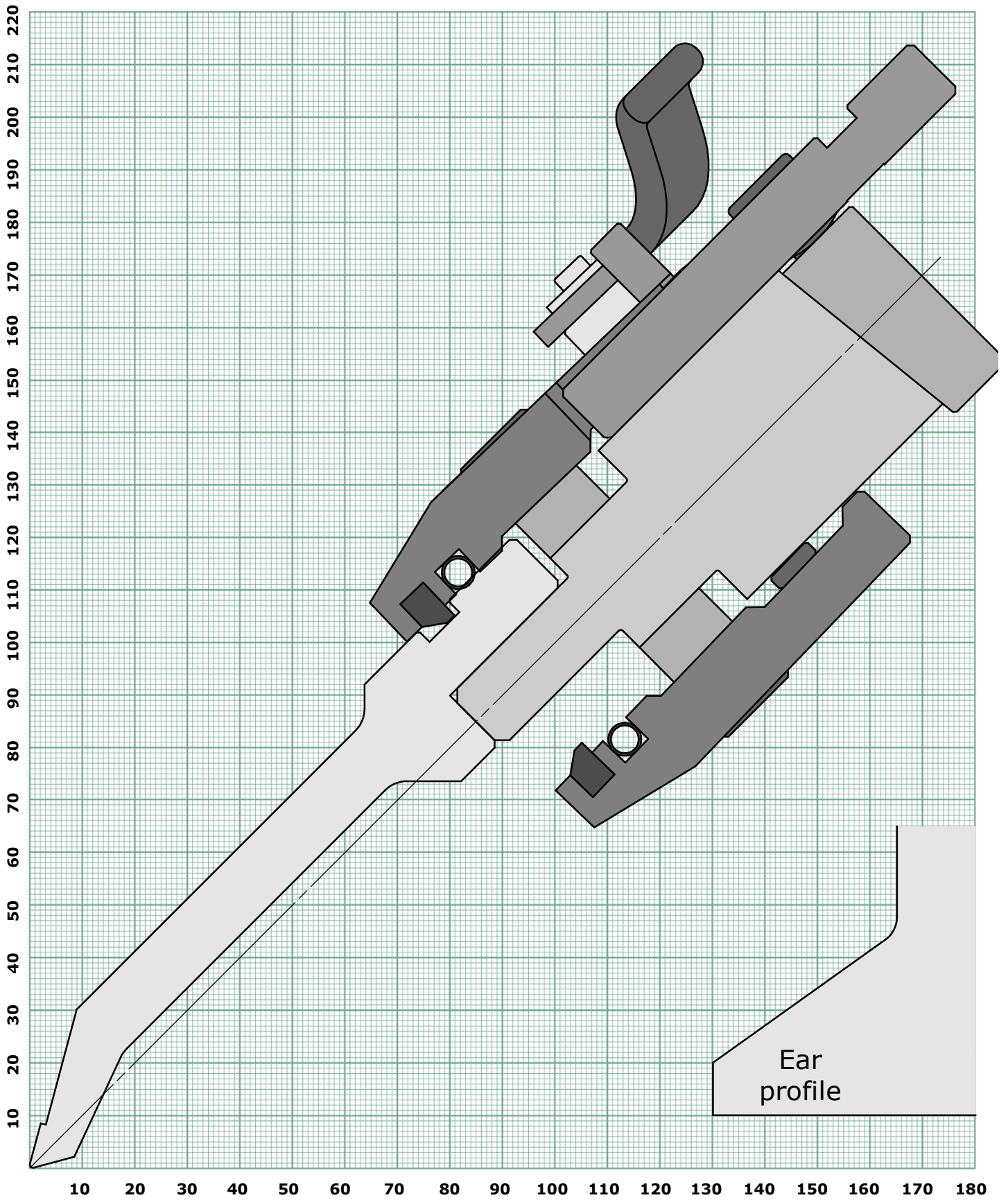

RETURN BEND LIMIT GRAPH
PUNCH 841

[← Back to index](#)

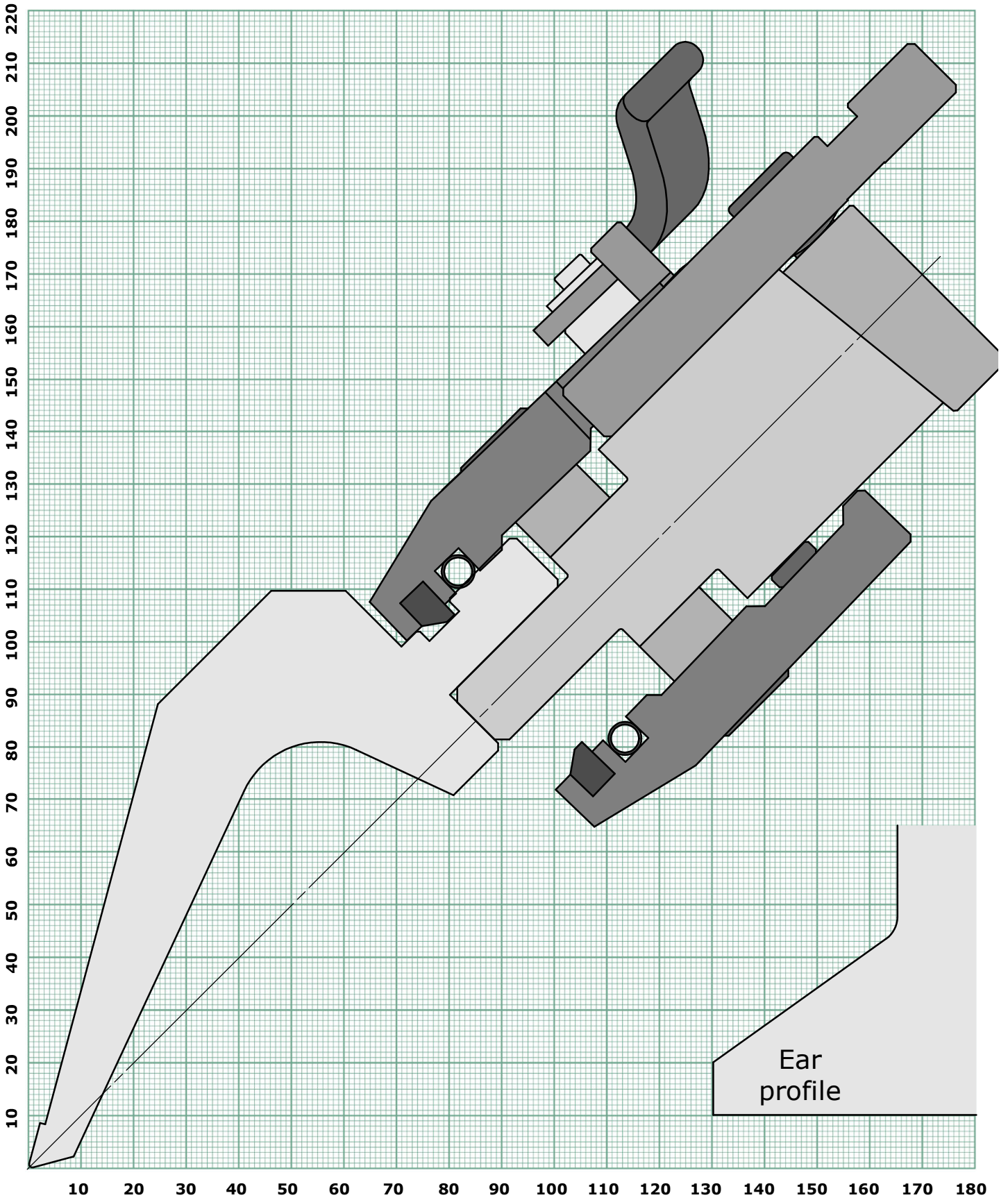

Ear profile

RETURN BEND LIMIT GRAPH
PUNCH 803

[← Back to index](#)

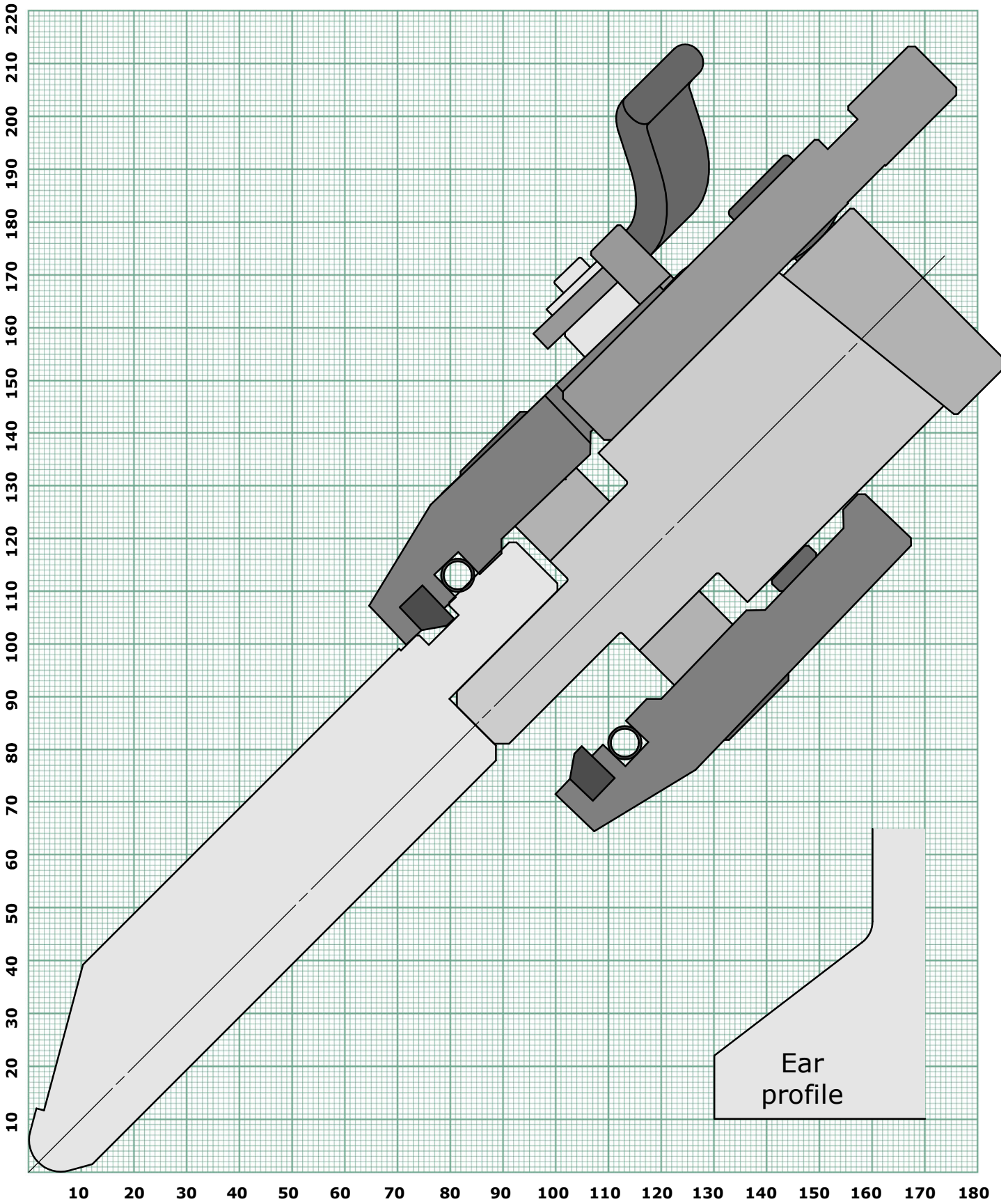

RETURN BEND LIMIT GRAPH
PUNCH 847 (C847)

[← Back to index](#)

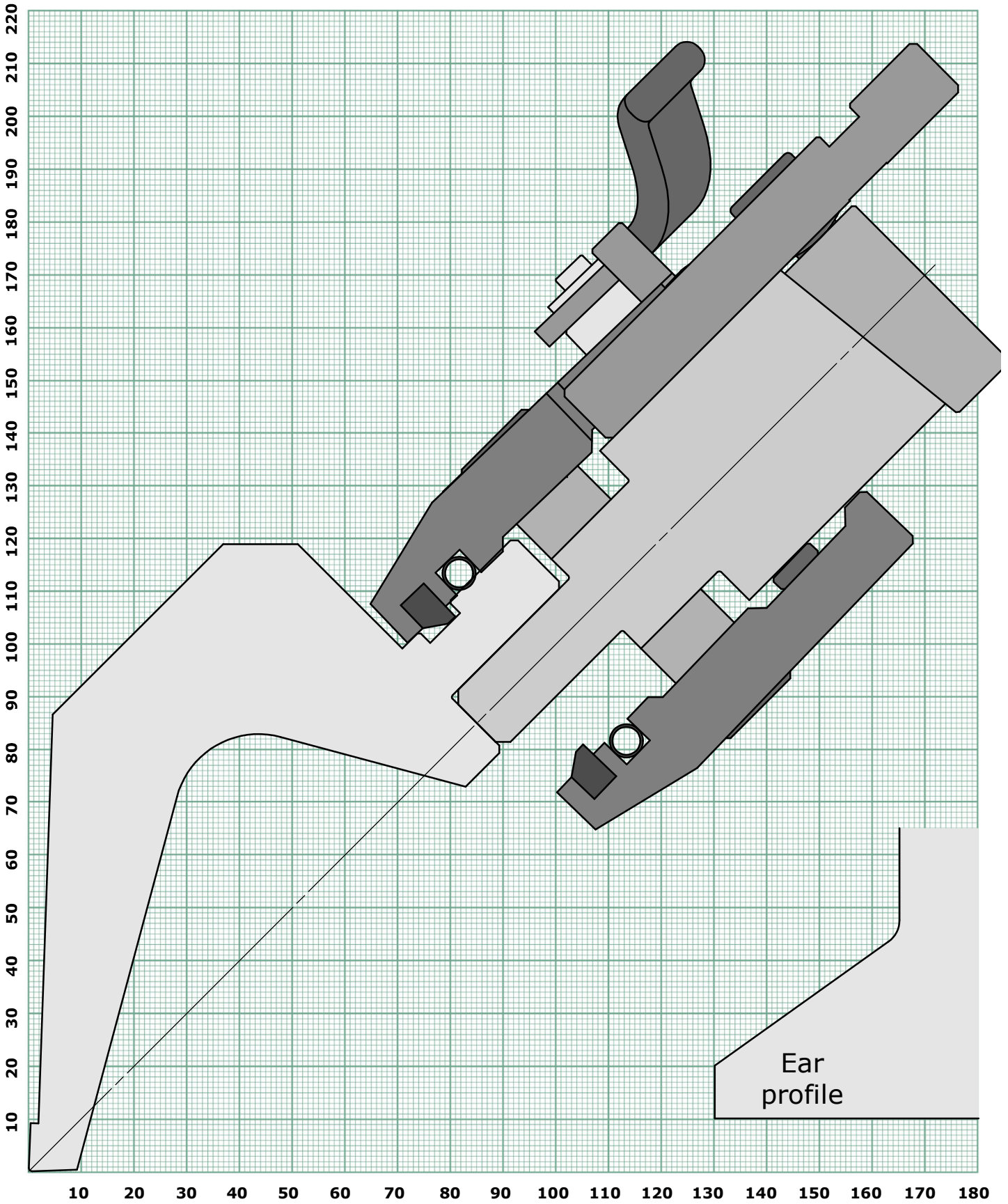

RETURN BEND LIMIT GRAPH
PUNCH 846 (C846)

[← Back to index](#)

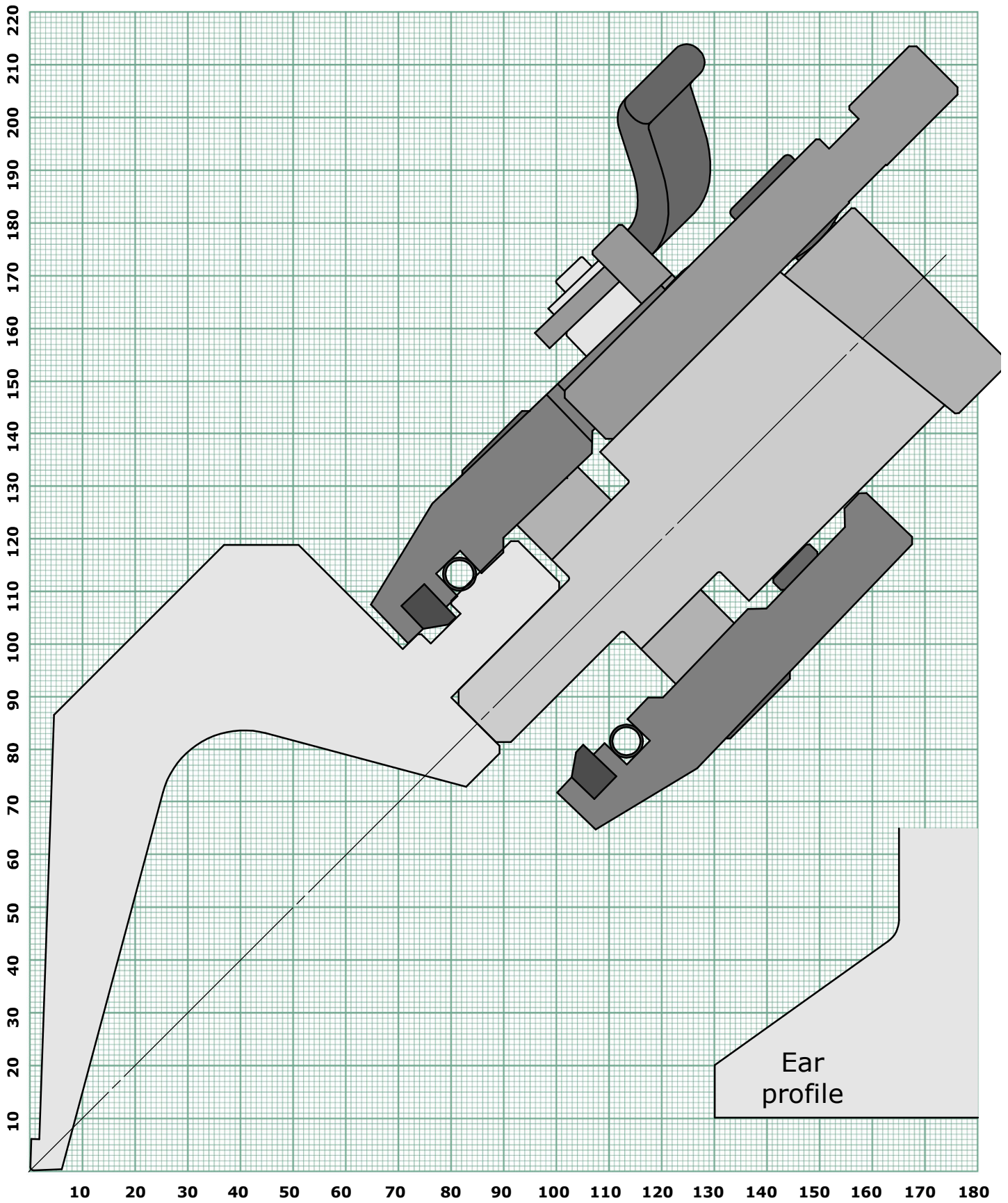

RETURN BEND LIMIT GRAPH
PUNCH 704

[← Back to index](#)

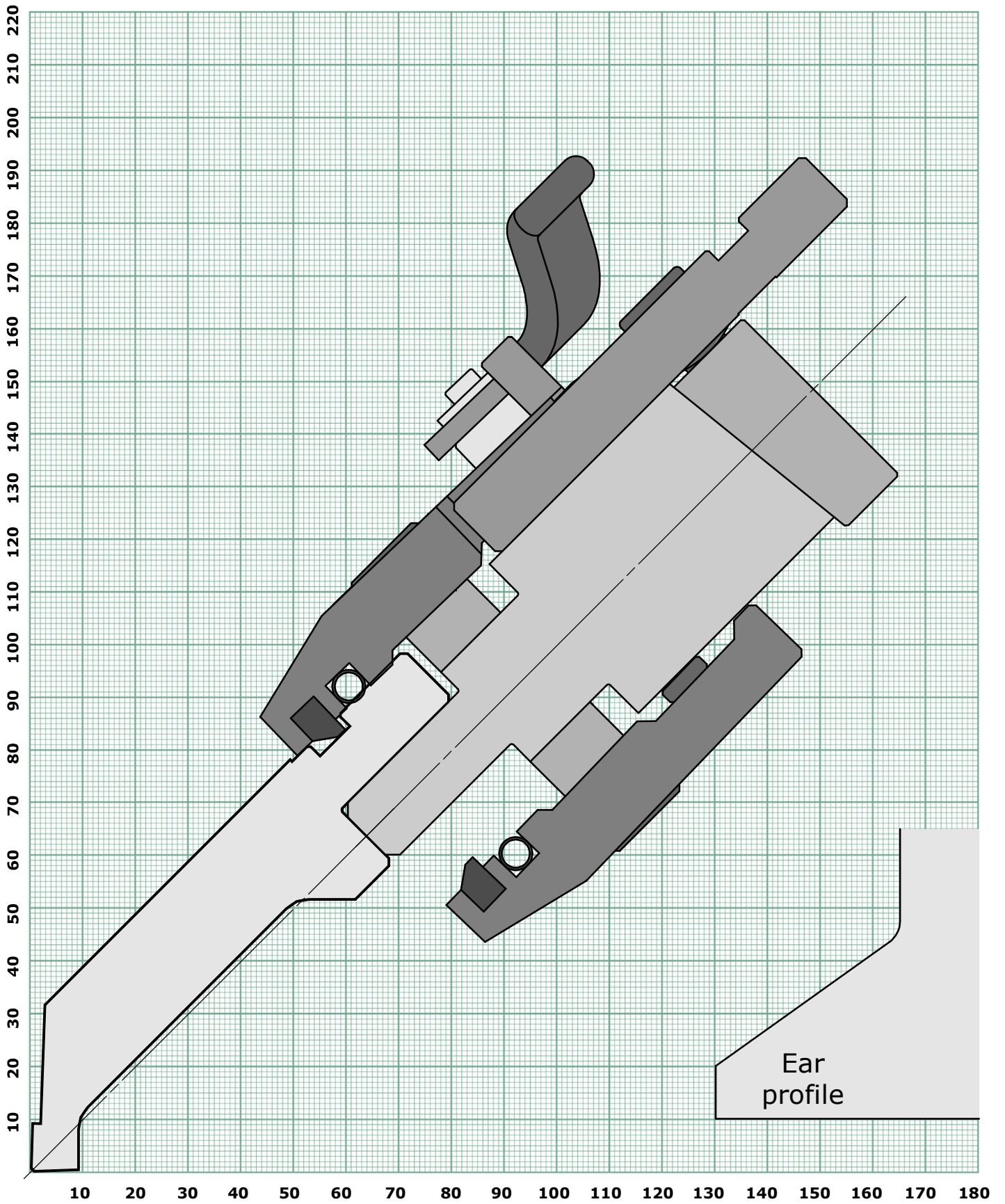

RETURN BEND LIMIT GRAPH
PUNCH 717

[← Back to index](#)

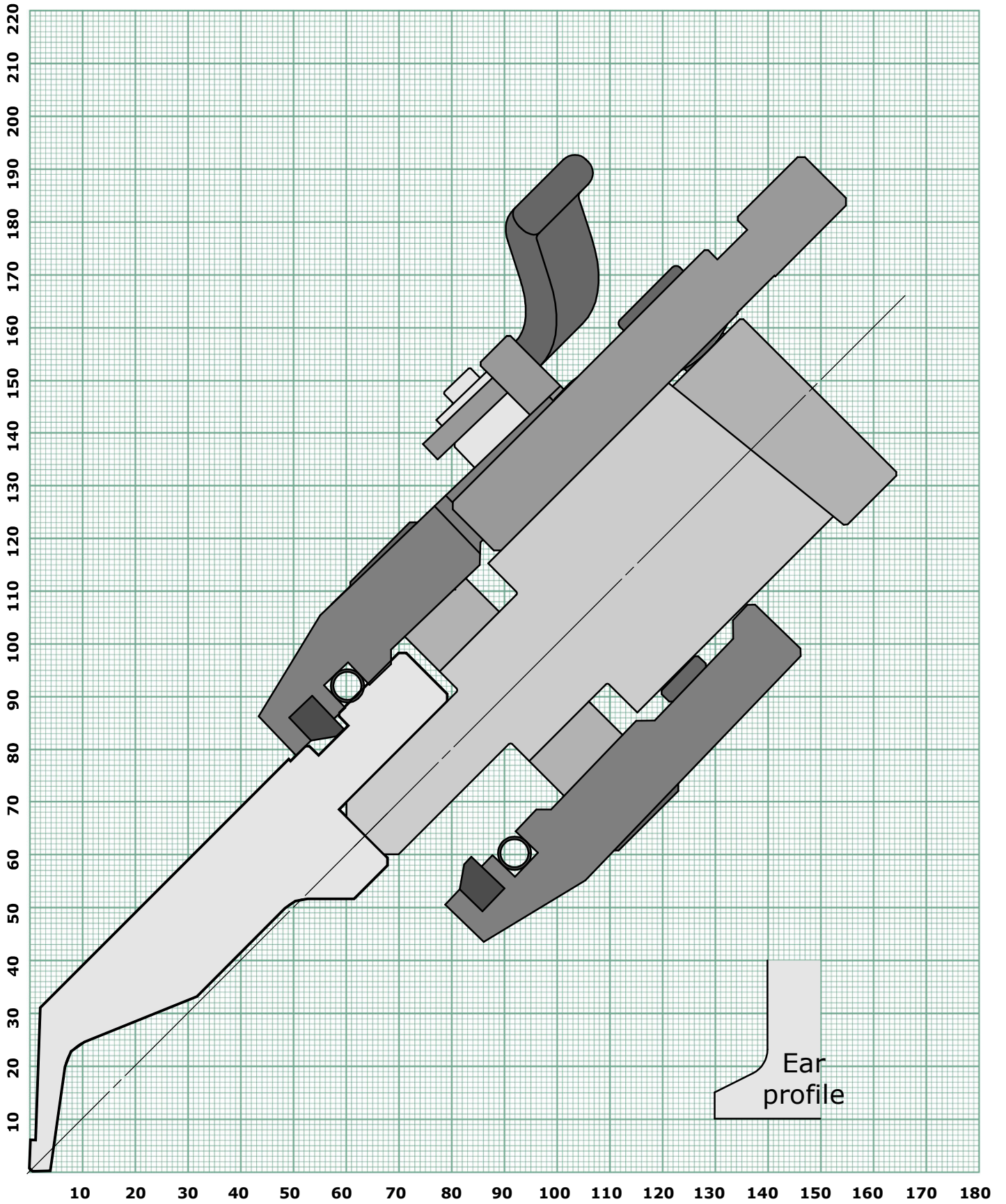

RETURN BEND LIMIT GRAPH
PUNCH 747

[← Back to index](#)

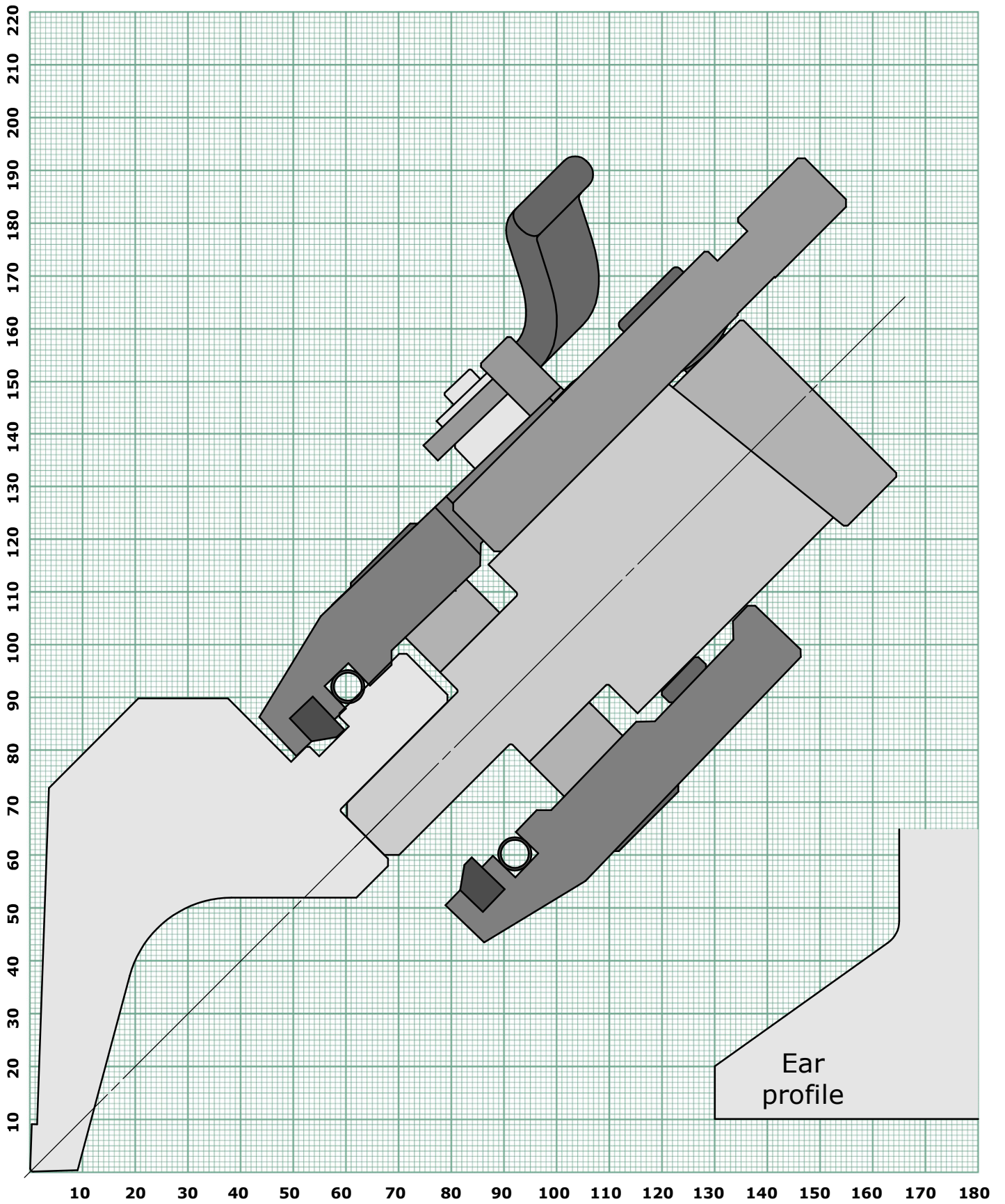

RETURN BEND LIMIT GRAPH
PUNCH 746

[← Back to index](#)

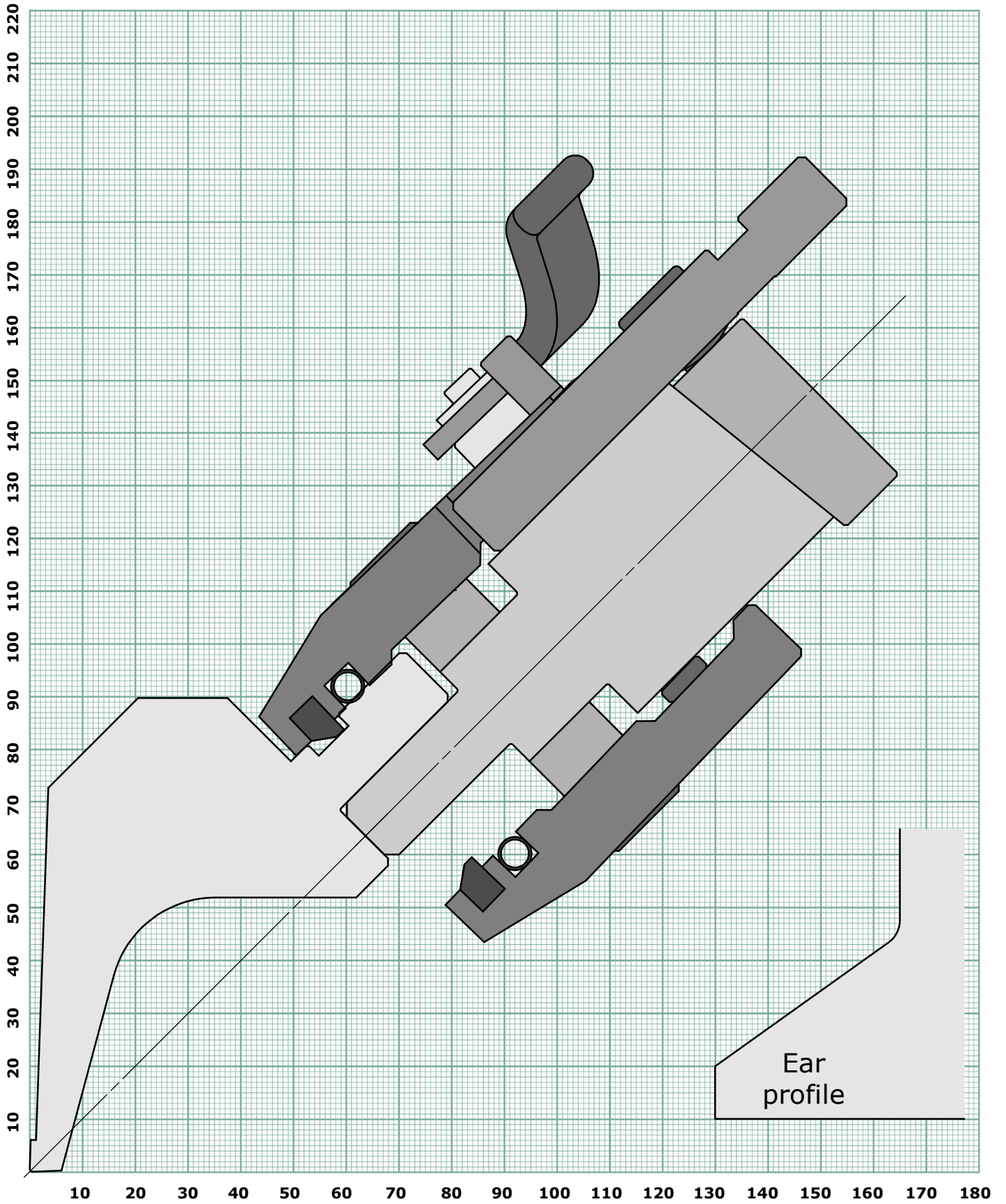

RETURN BEND LIMIT GRAPH
PUNCH 720

[← Back to index](#)

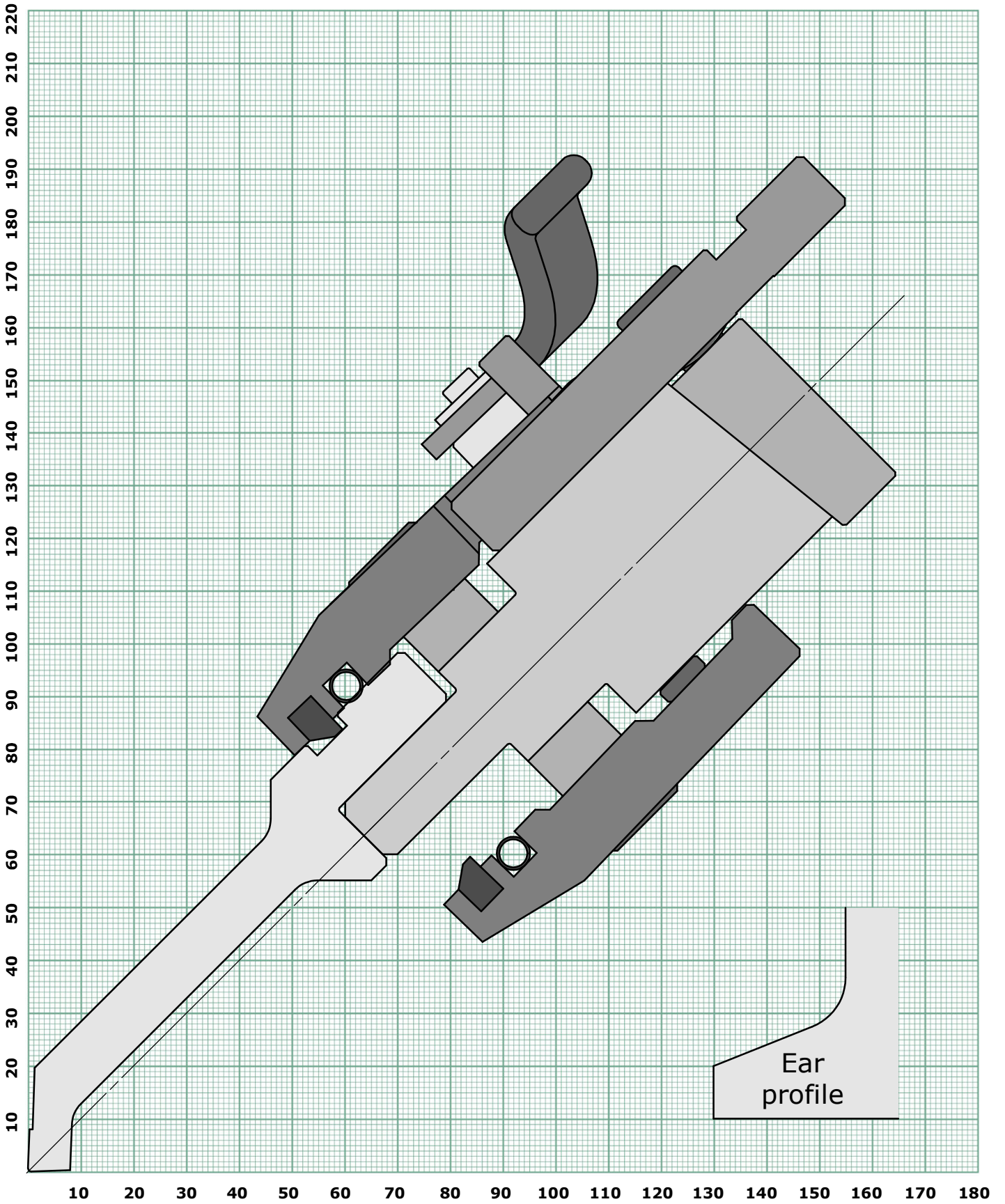

RETURN BEND LIMIT GRAPH
PUNCH 713

← Back to index

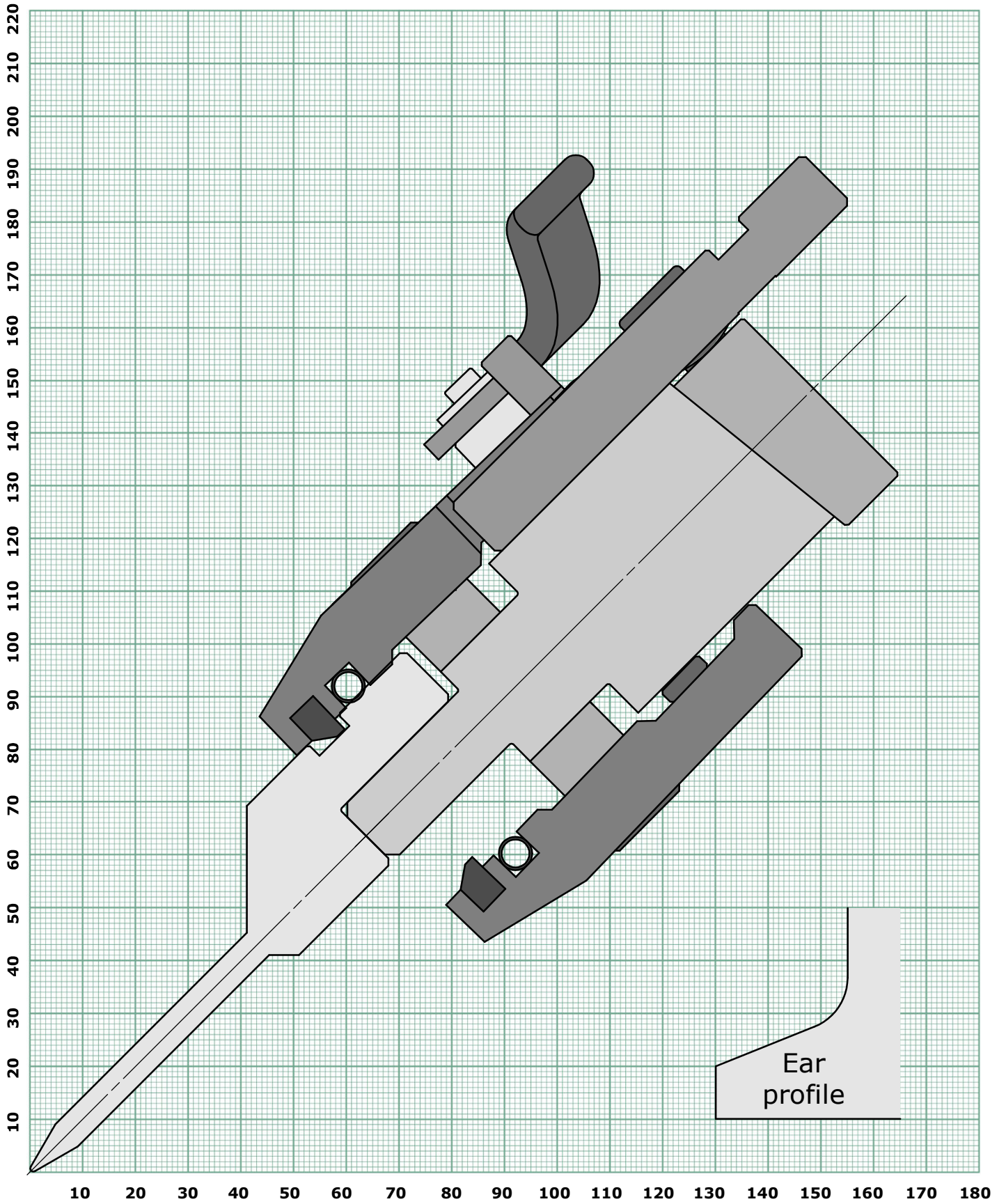

RETURN BEND LIMIT GRAPH
PUNCH 731-R0,6

[← Back to index](#)

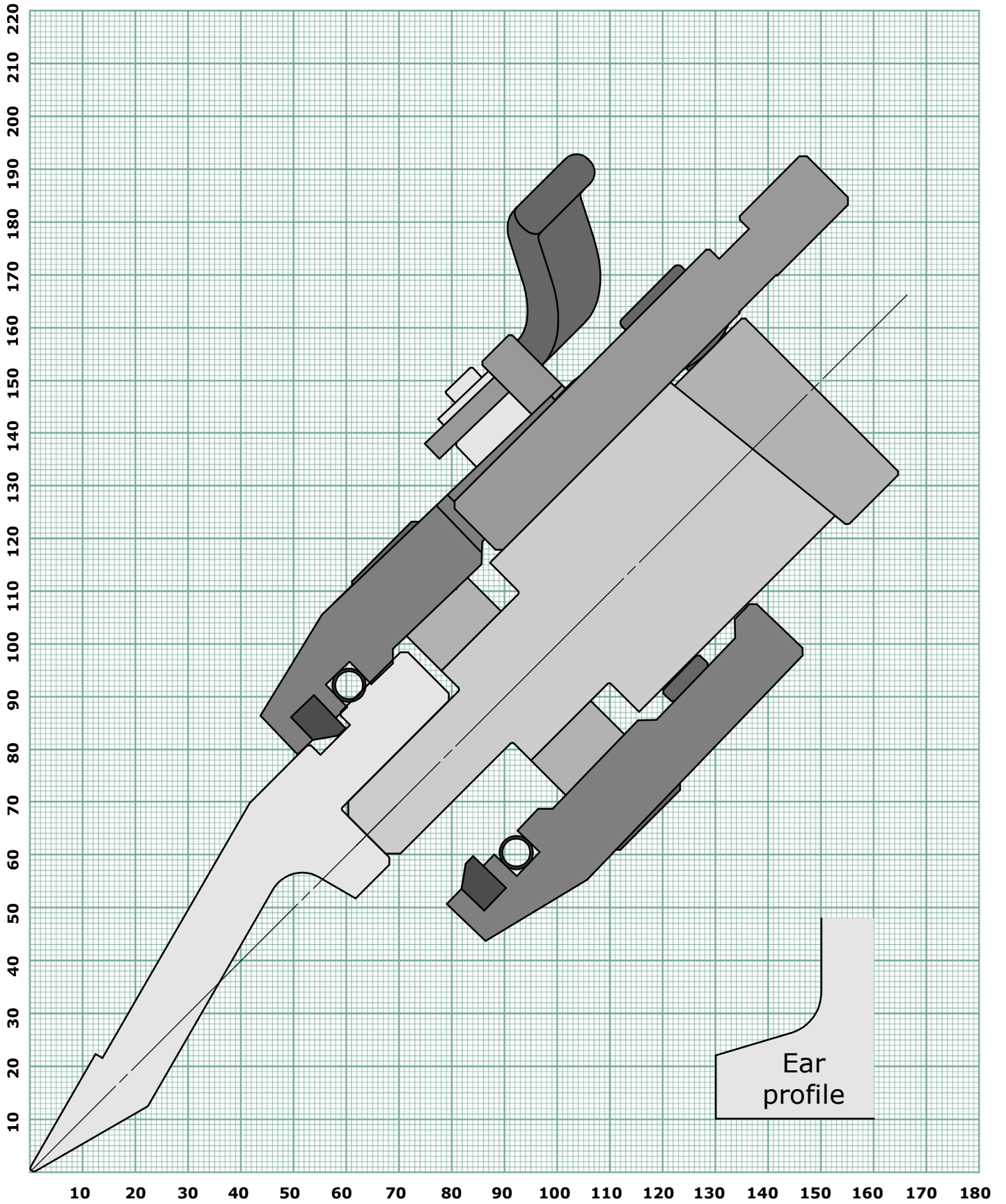

RETURN BEND LIMIT GRAPH
PUNCH 731-R3

[← Back to index](#)

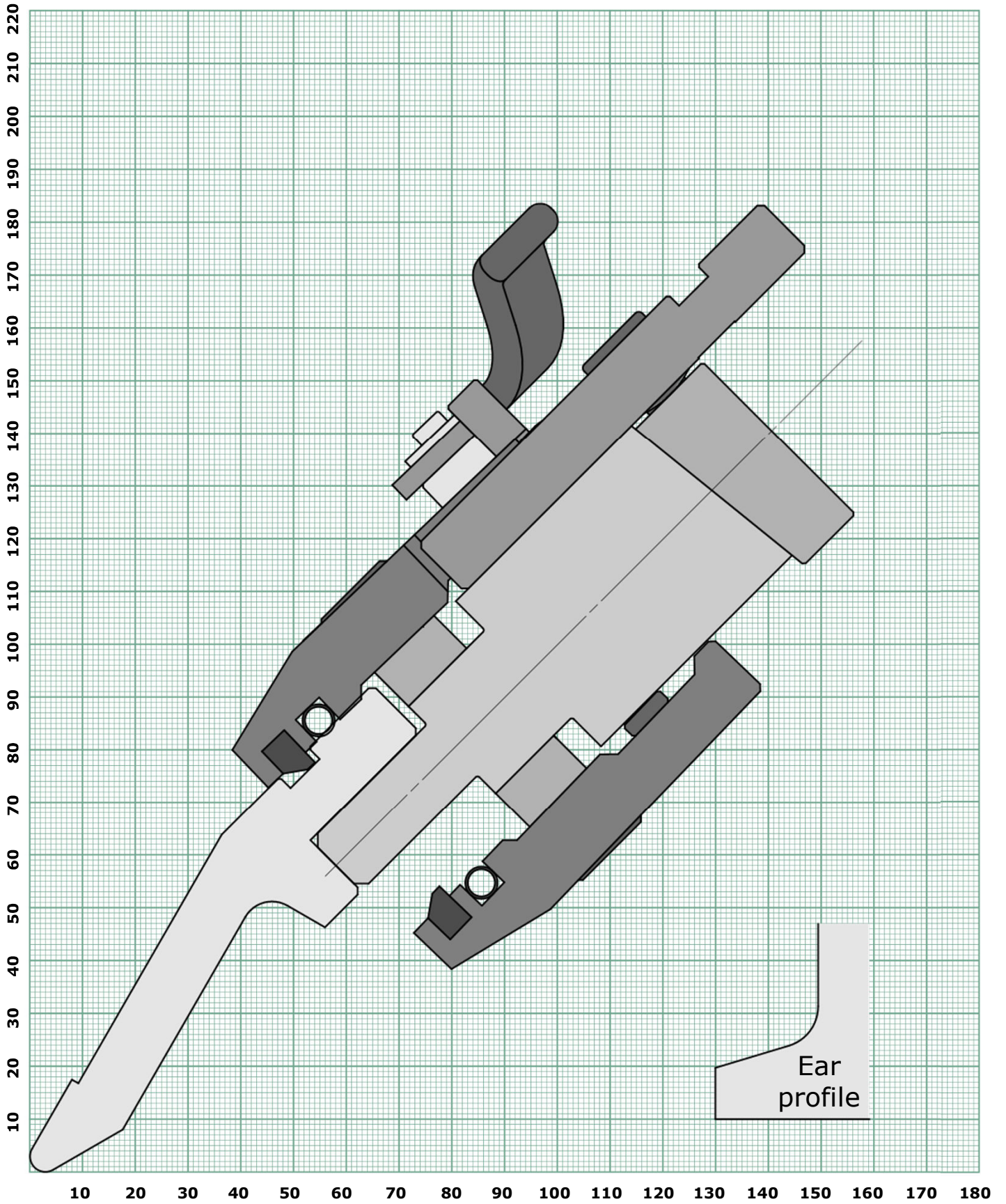

RETURN BEND LIMIT GRAPH
PUNCH 904

[← Back to index](#)

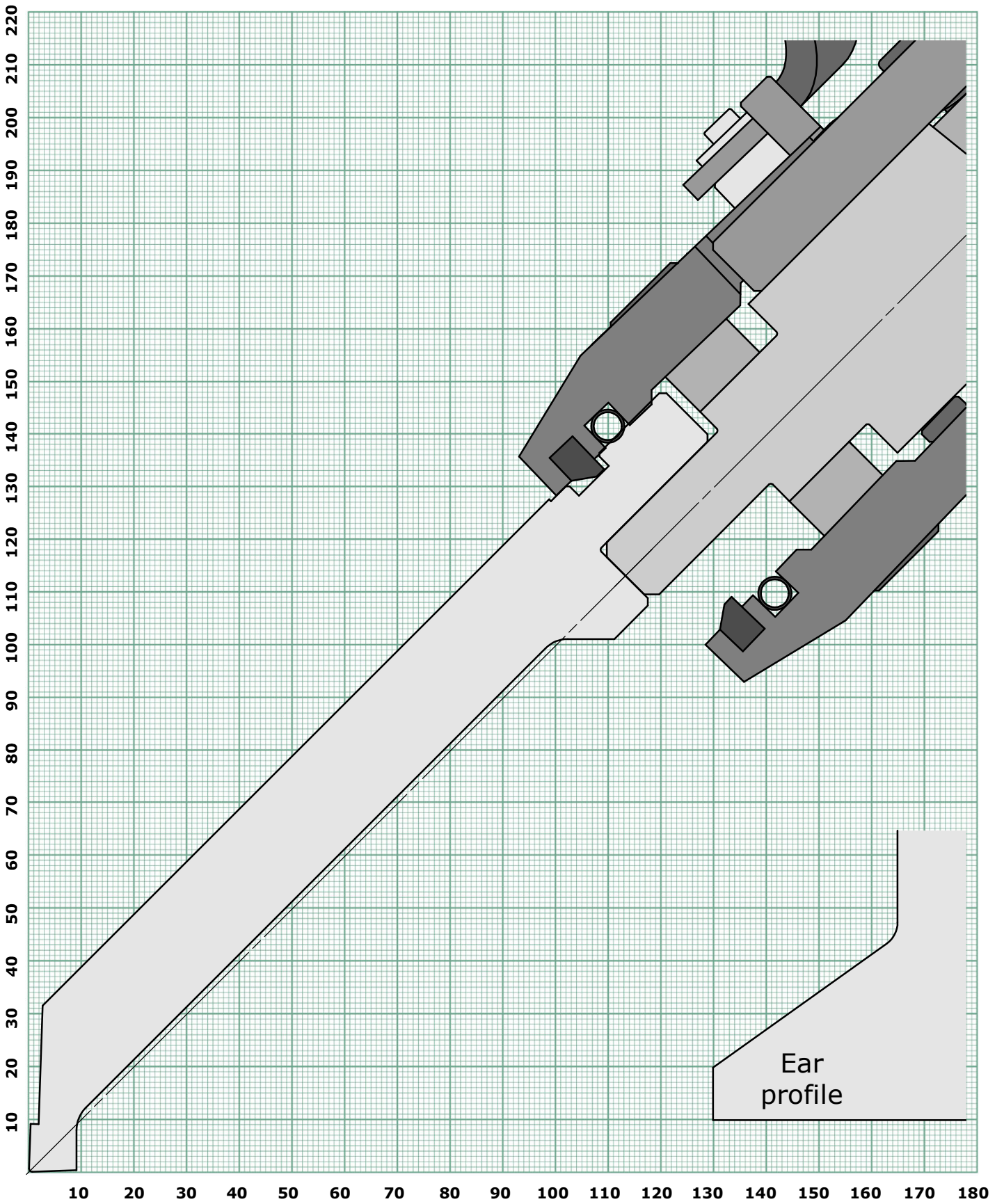

RETURN BEND LIMIT GRAPH
PUNCH 914

[← Back to index](#)

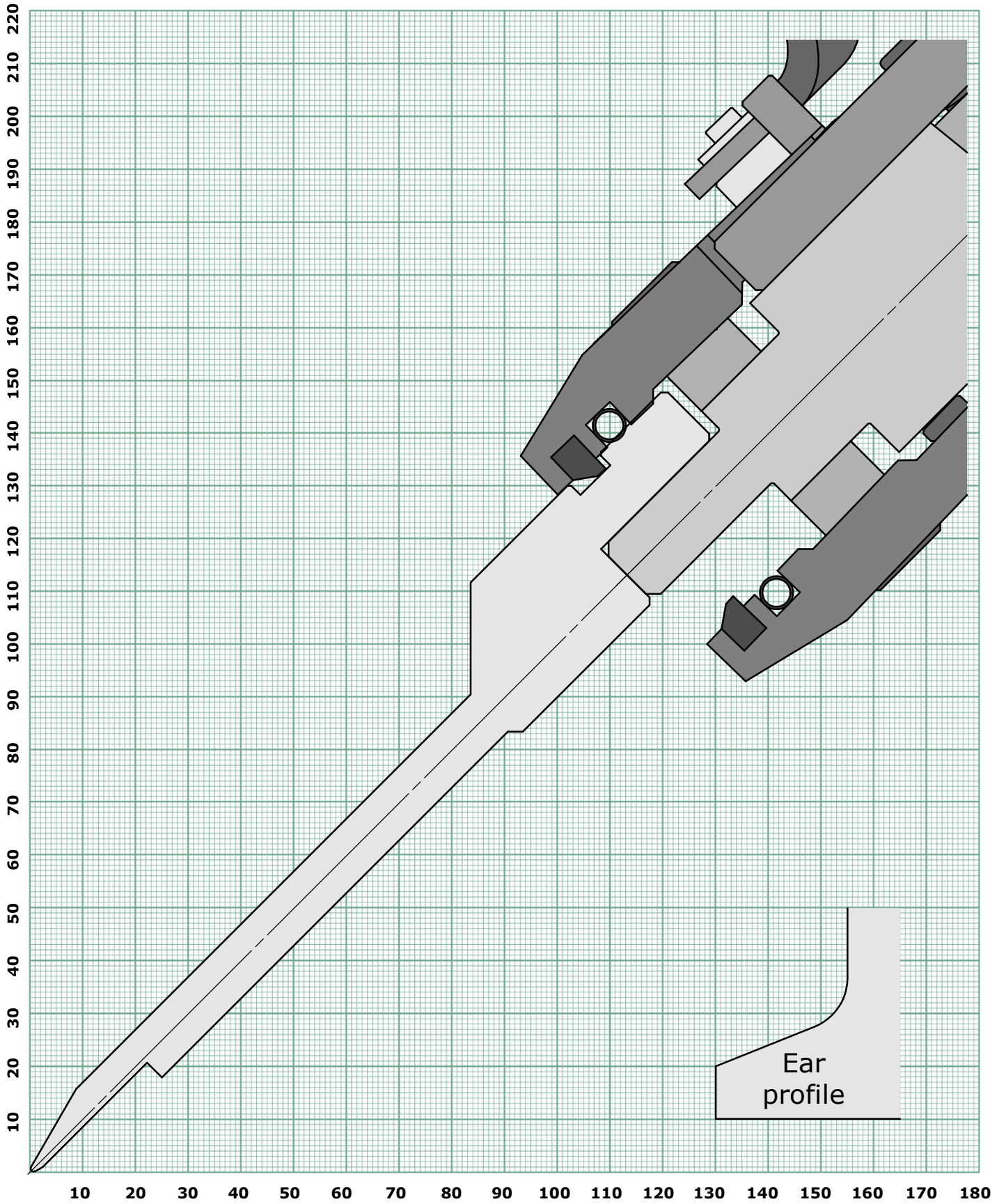

RETURN BEND LIMIT GRAPH
PUNCH 947

[← Back to index](#)

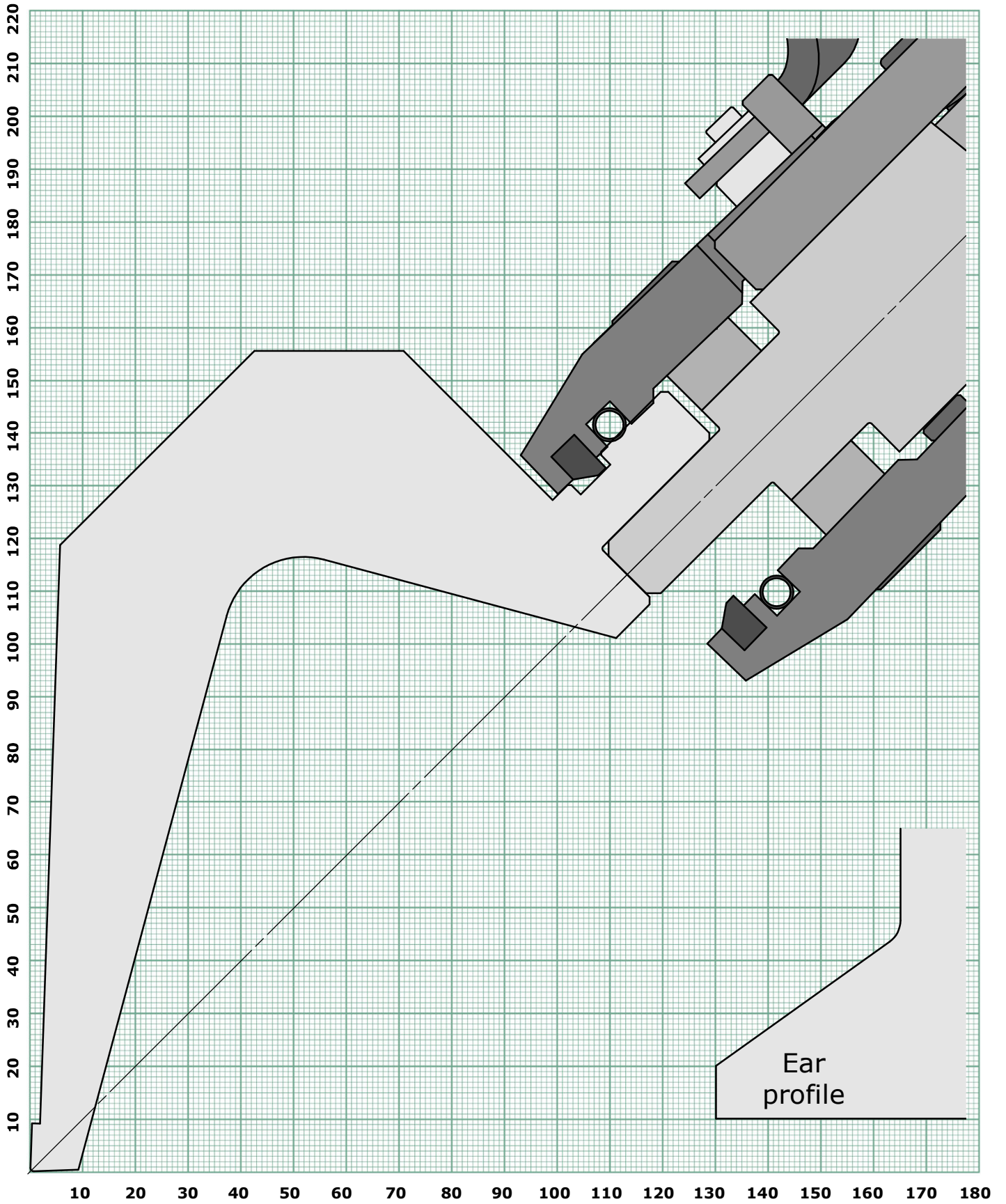

RETURN BEND LIMIT GRAPH
PUNCH 604

[← Back to index](#)

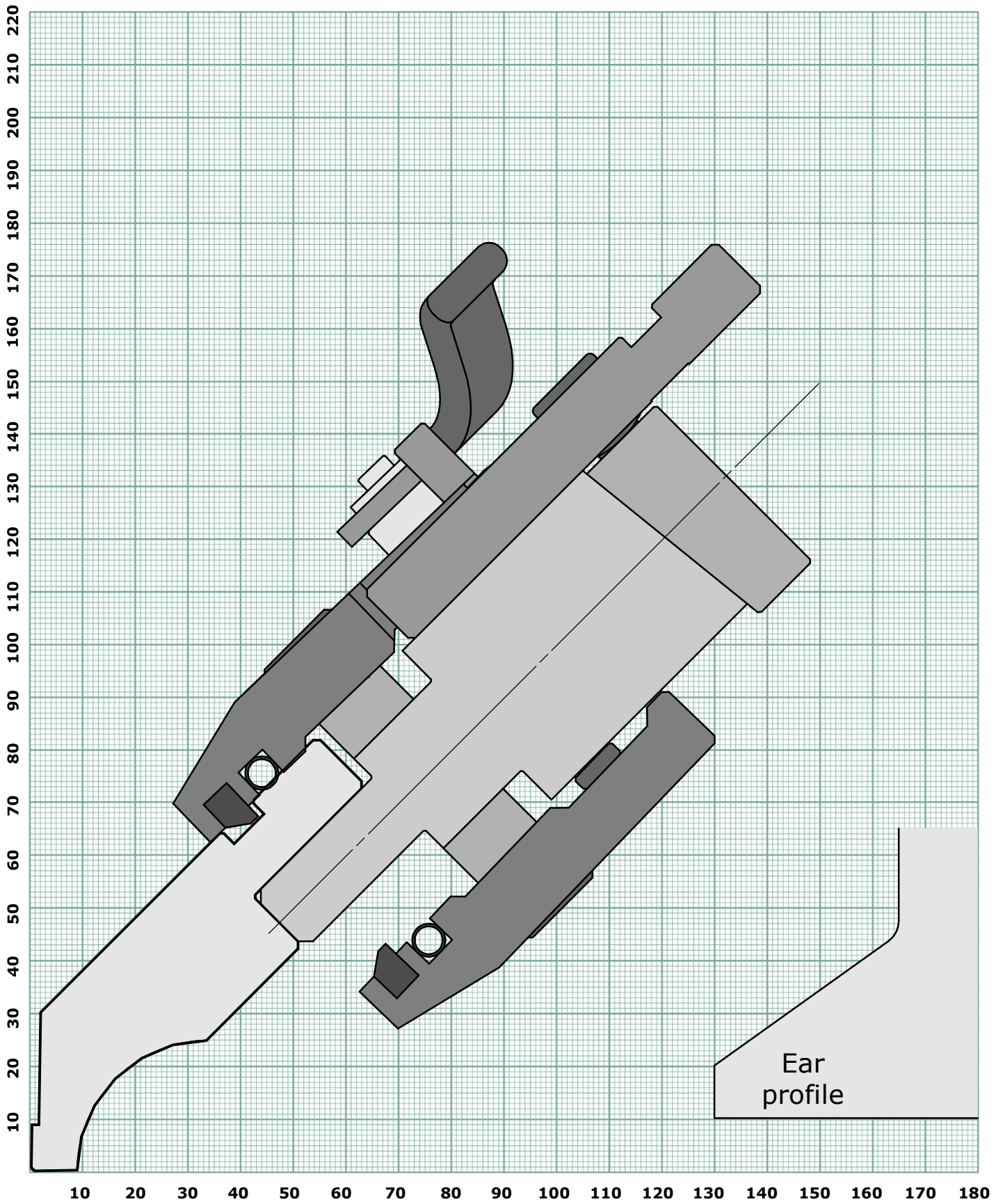

RETURN BEND LIMIT GRAPH
PUNCH 603

← Back to index

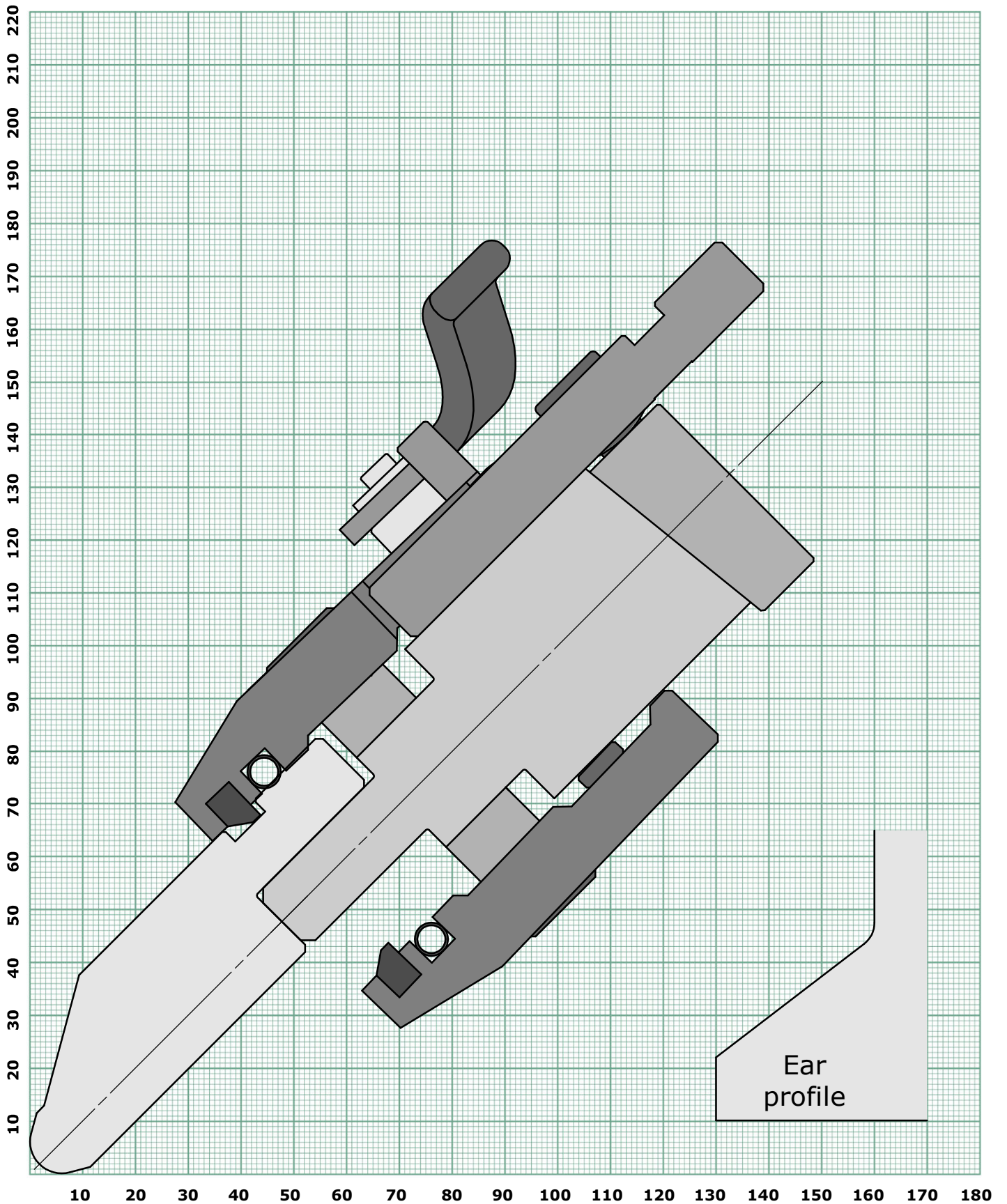

RETURN BEND LIMIT GRAPH
PUNCH 617

[← Back to index](#)

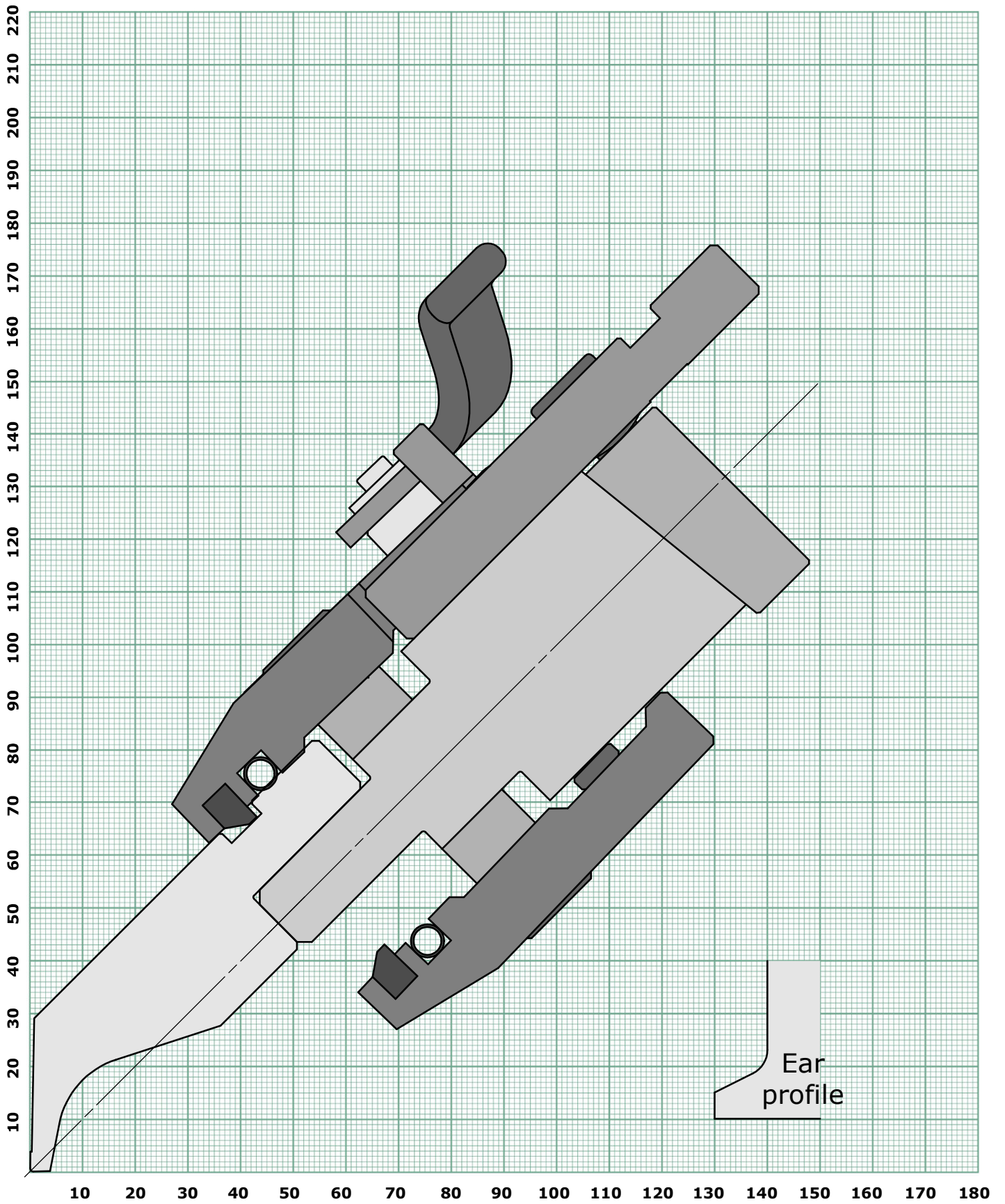

RETURN BEND LIMIT GRAPH
PUNCH 631

← Back to index

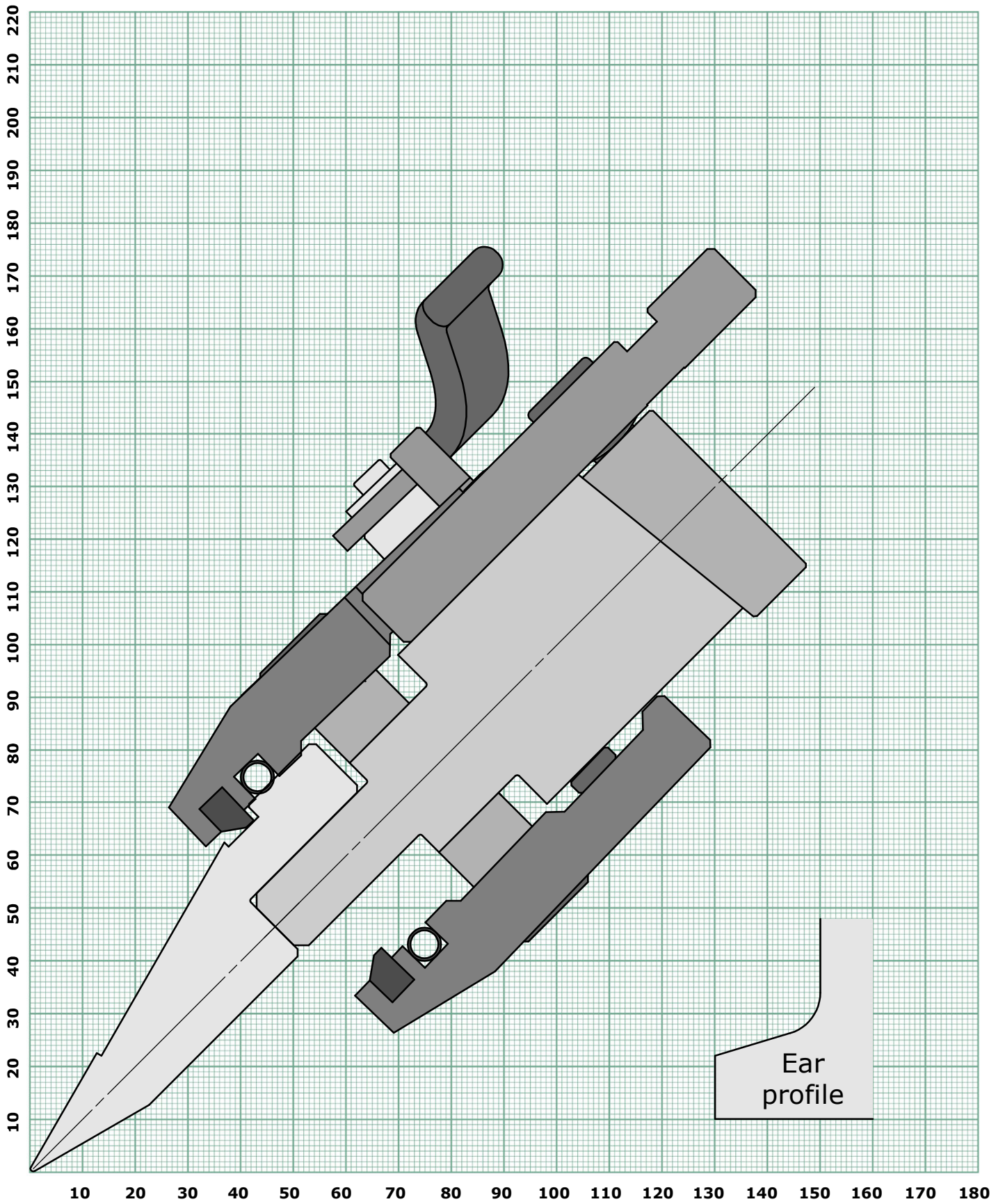

RETURN BEND LIMIT GRAPH
PUNCH 640

← Back to index

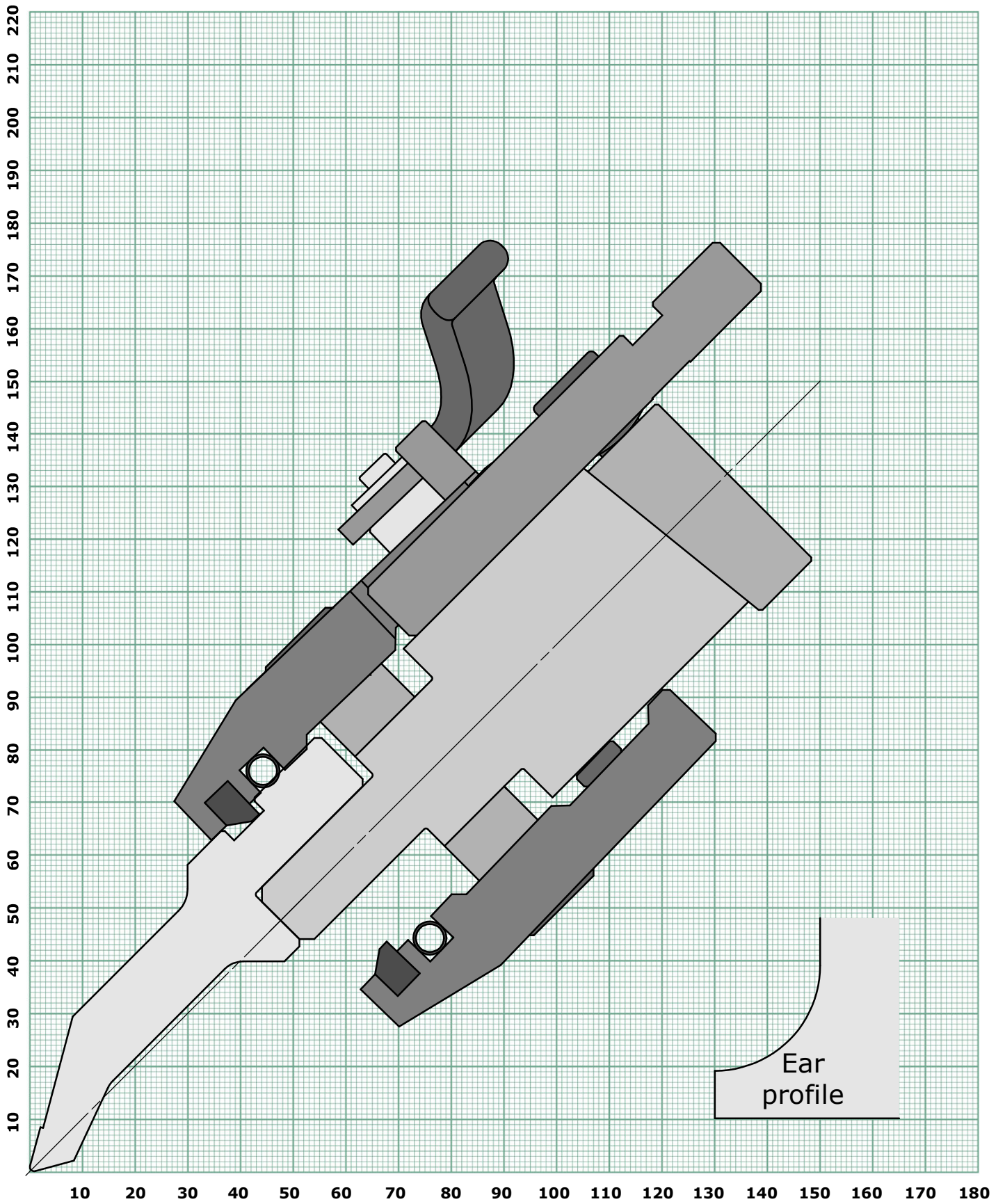

R7 Ruller with EH015 Holder

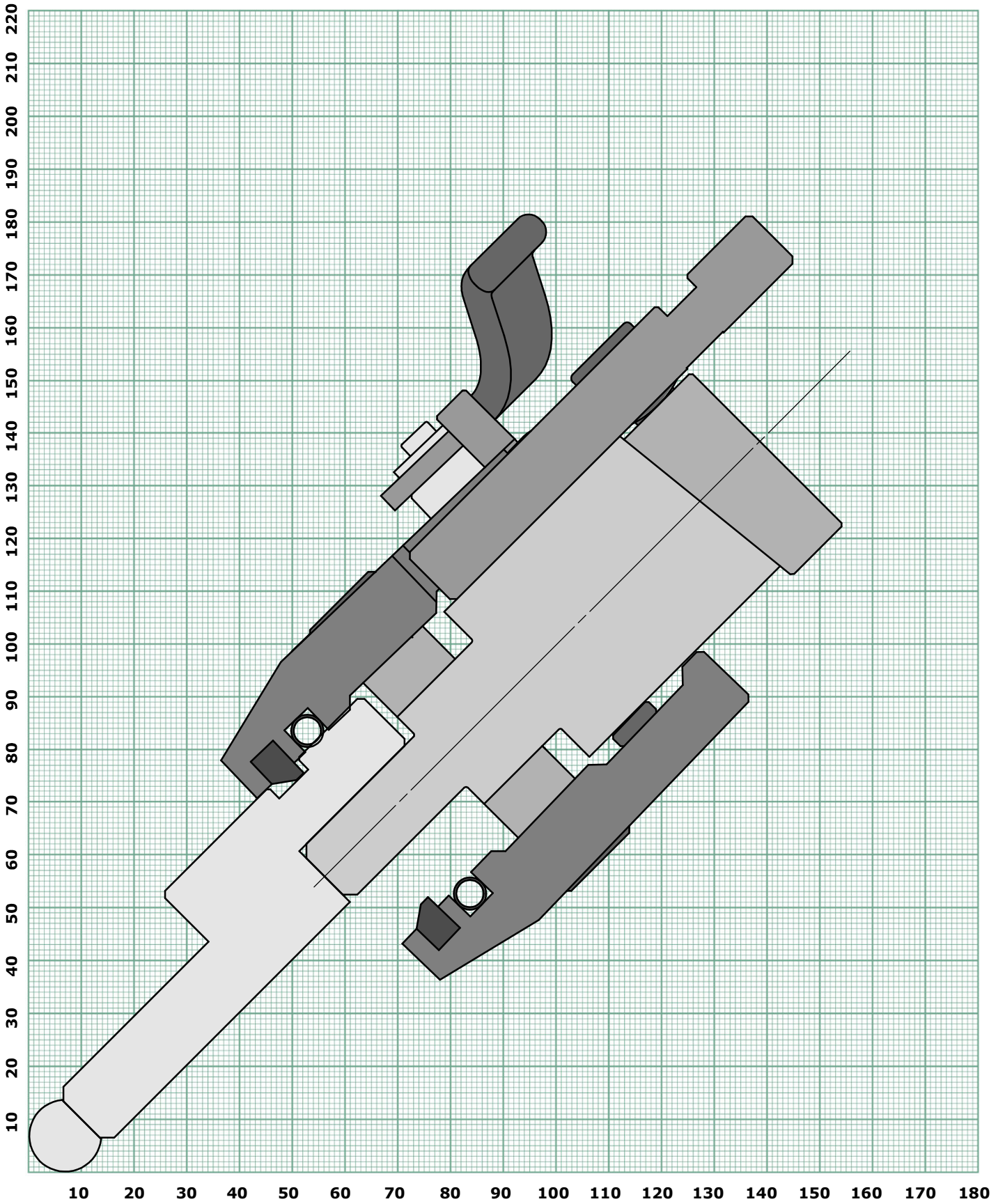

R8 Ruller with EH015 Holder

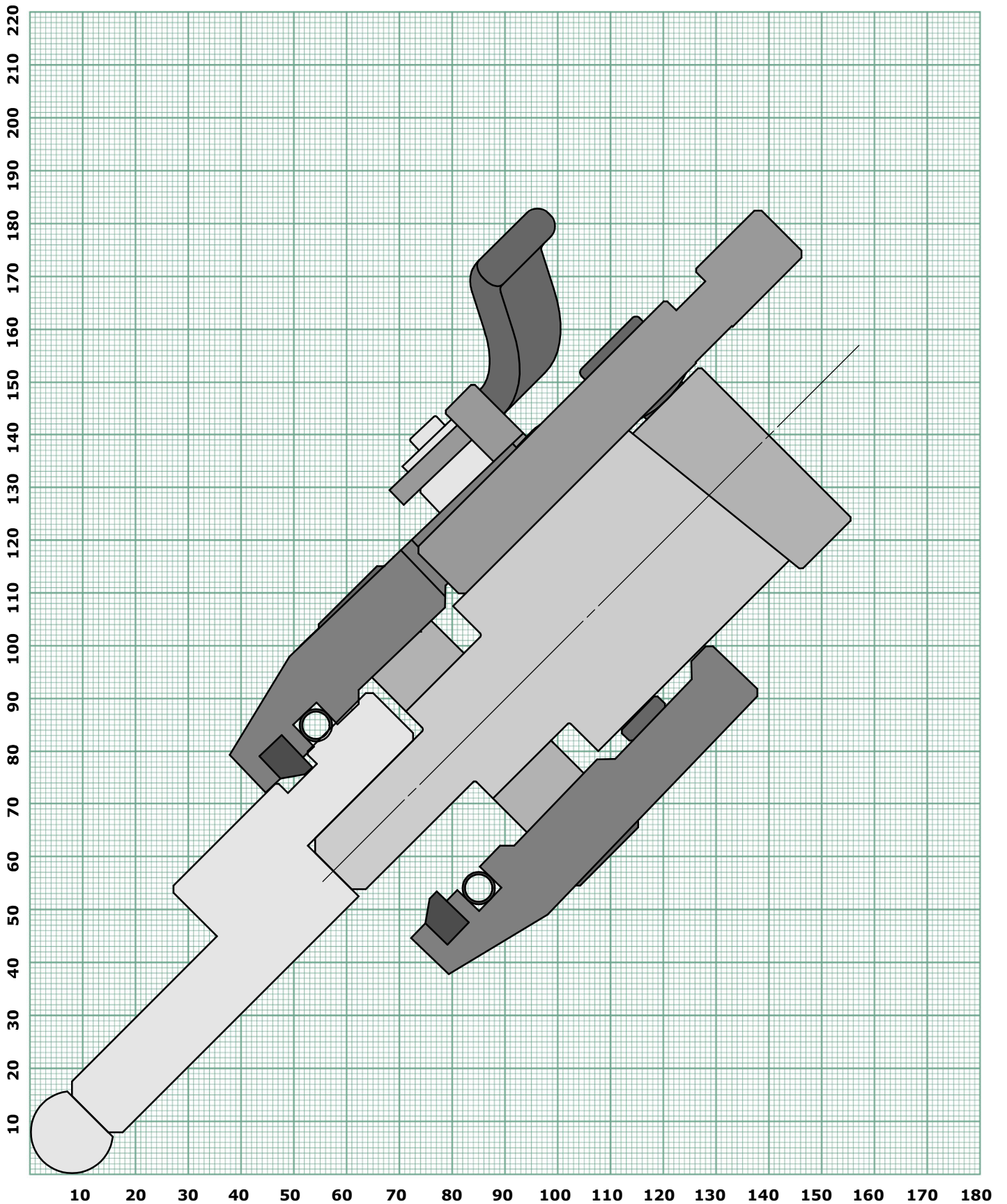

R9 Ruller with EH015 Holder

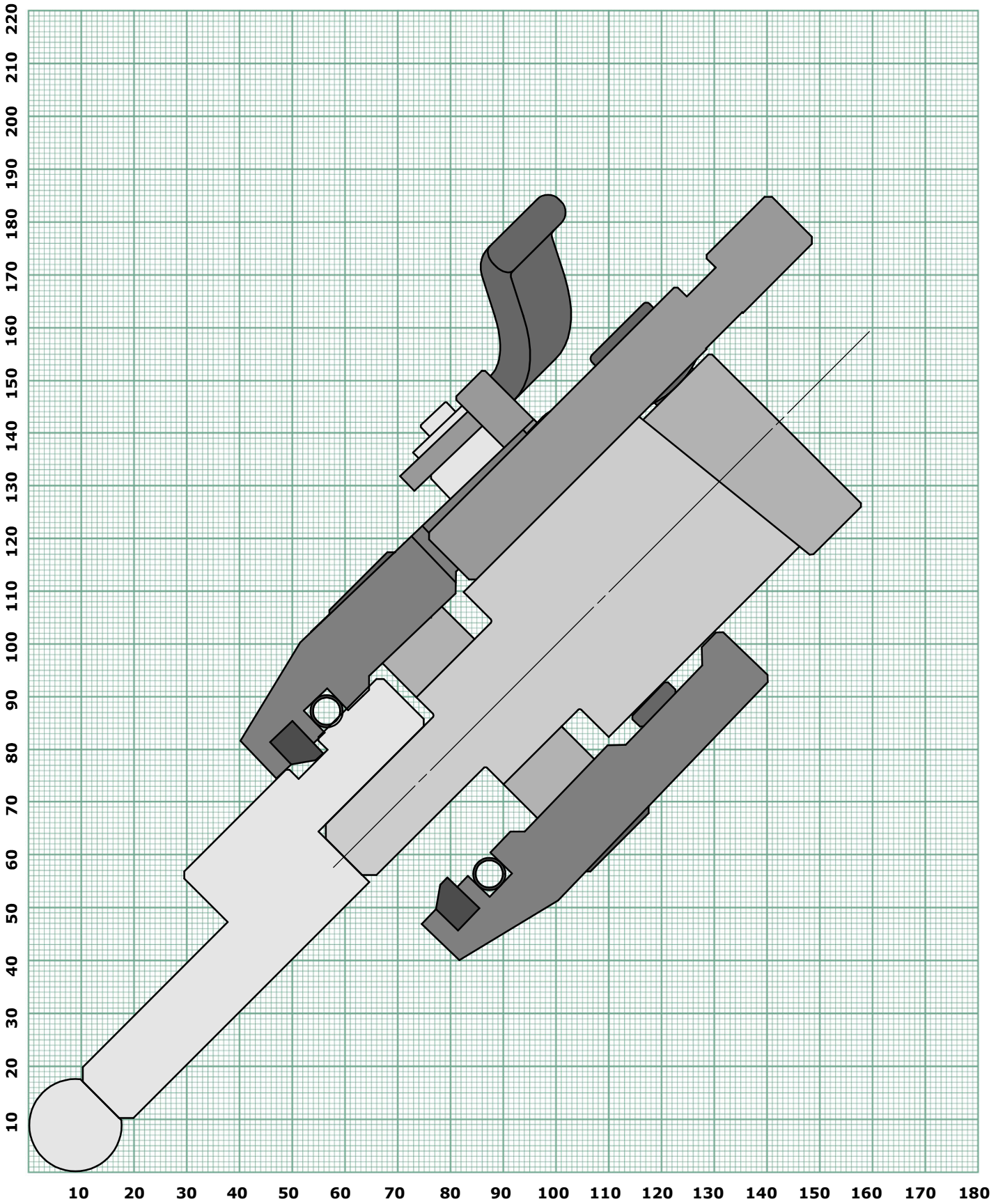

R10 Ruller with EH015 Holder

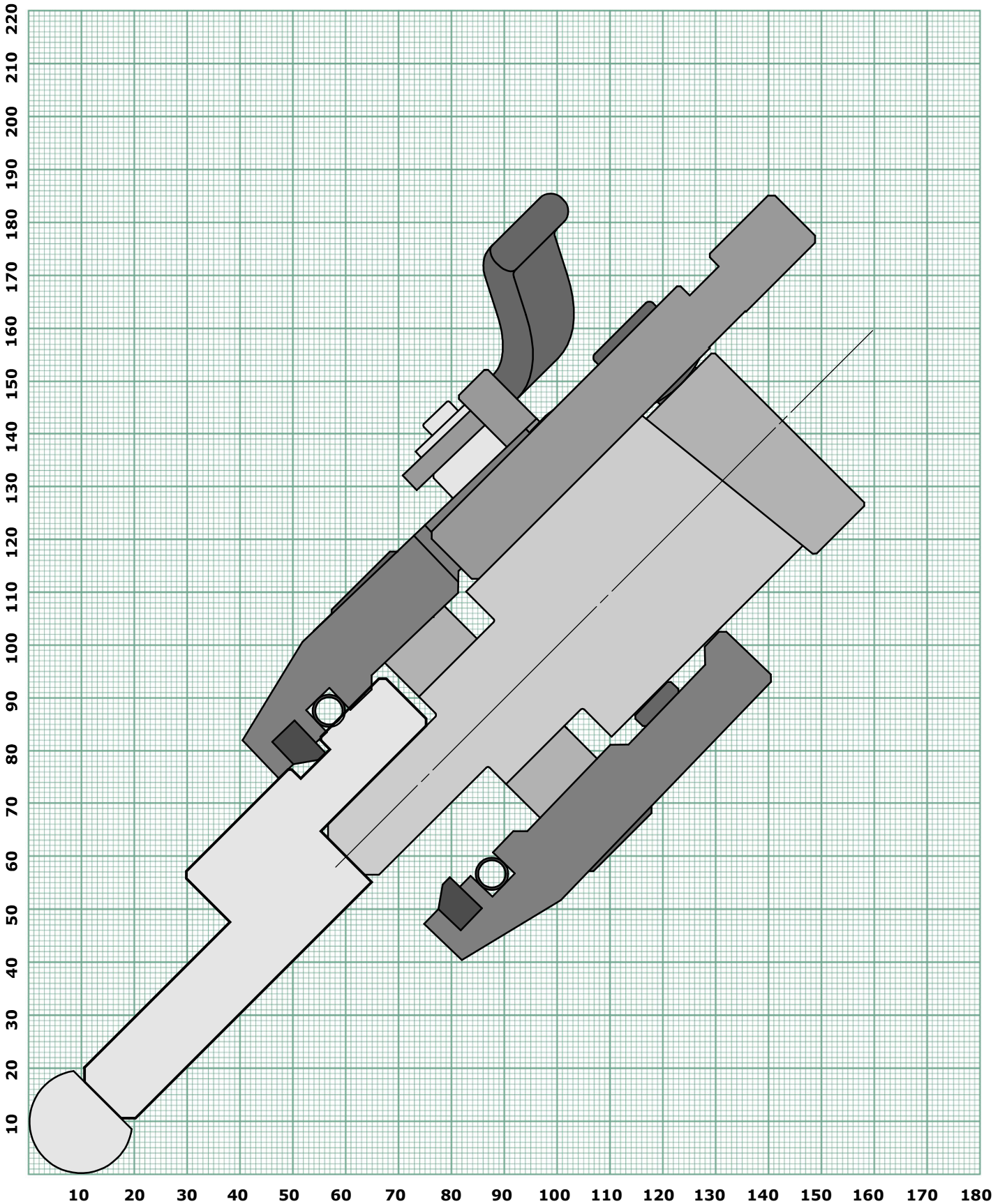

R11 Ruller with EH015 Holder

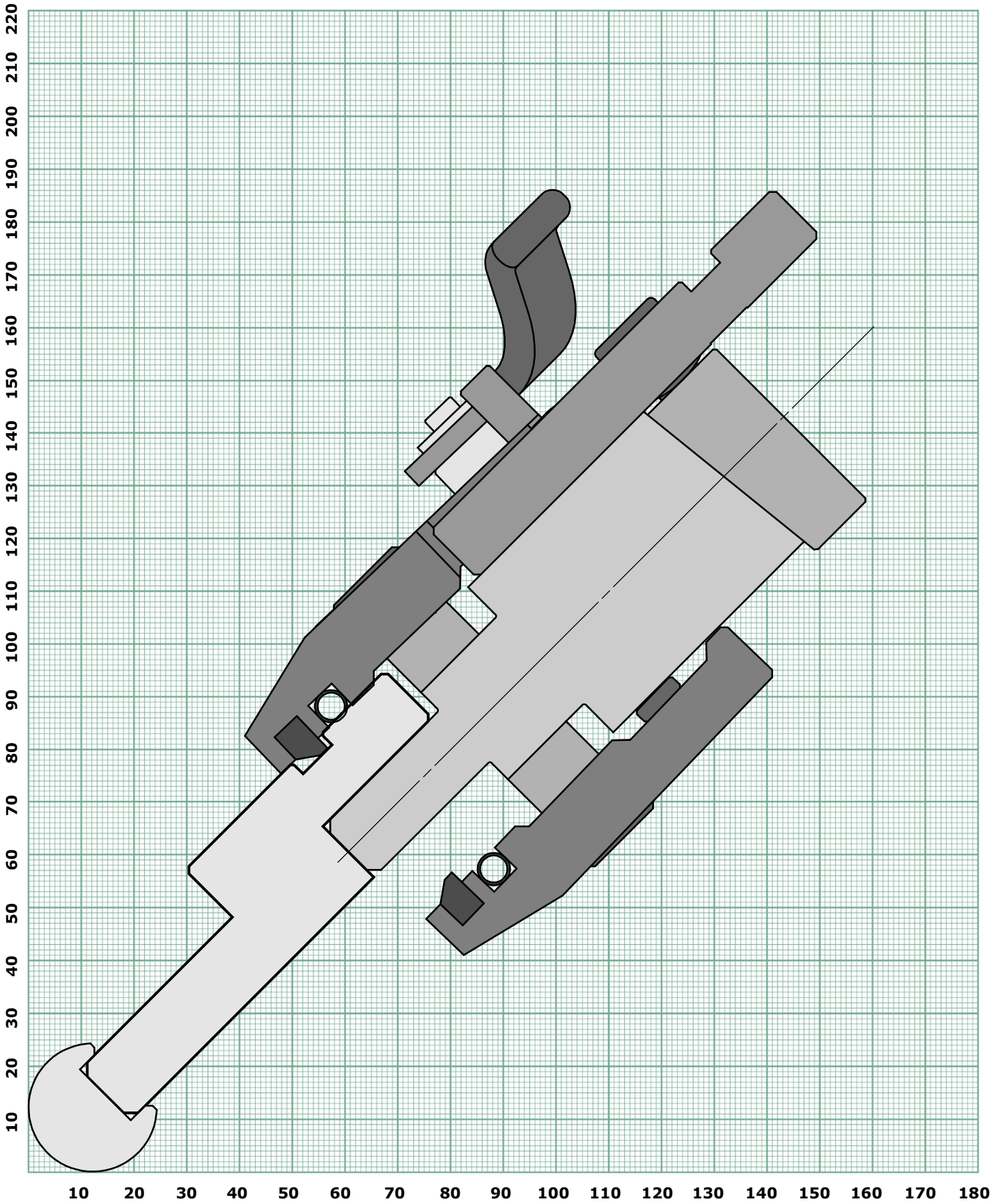

R12,5 Ruller with EH015 Holder

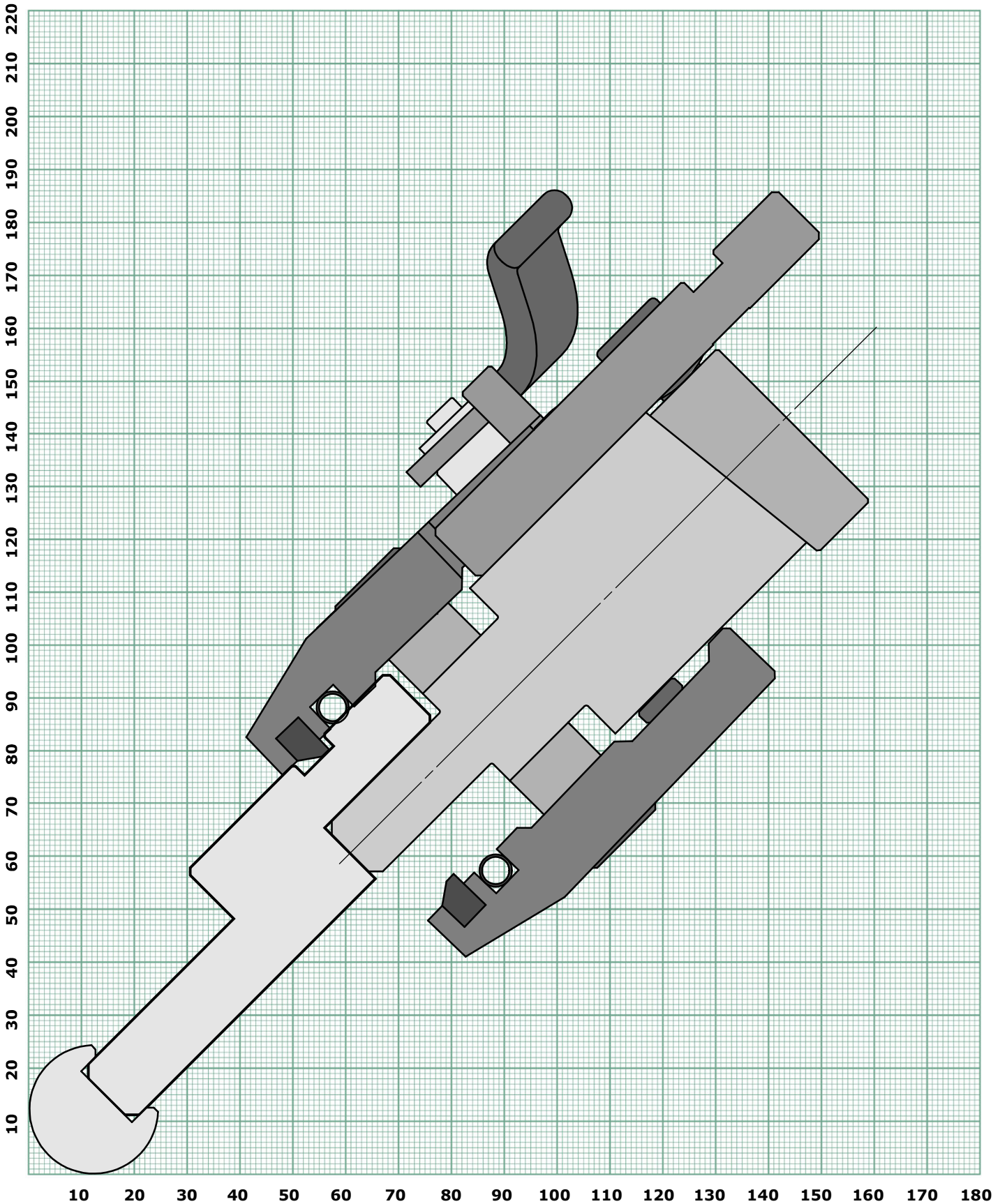

R14 Ruller with EH015 Holder

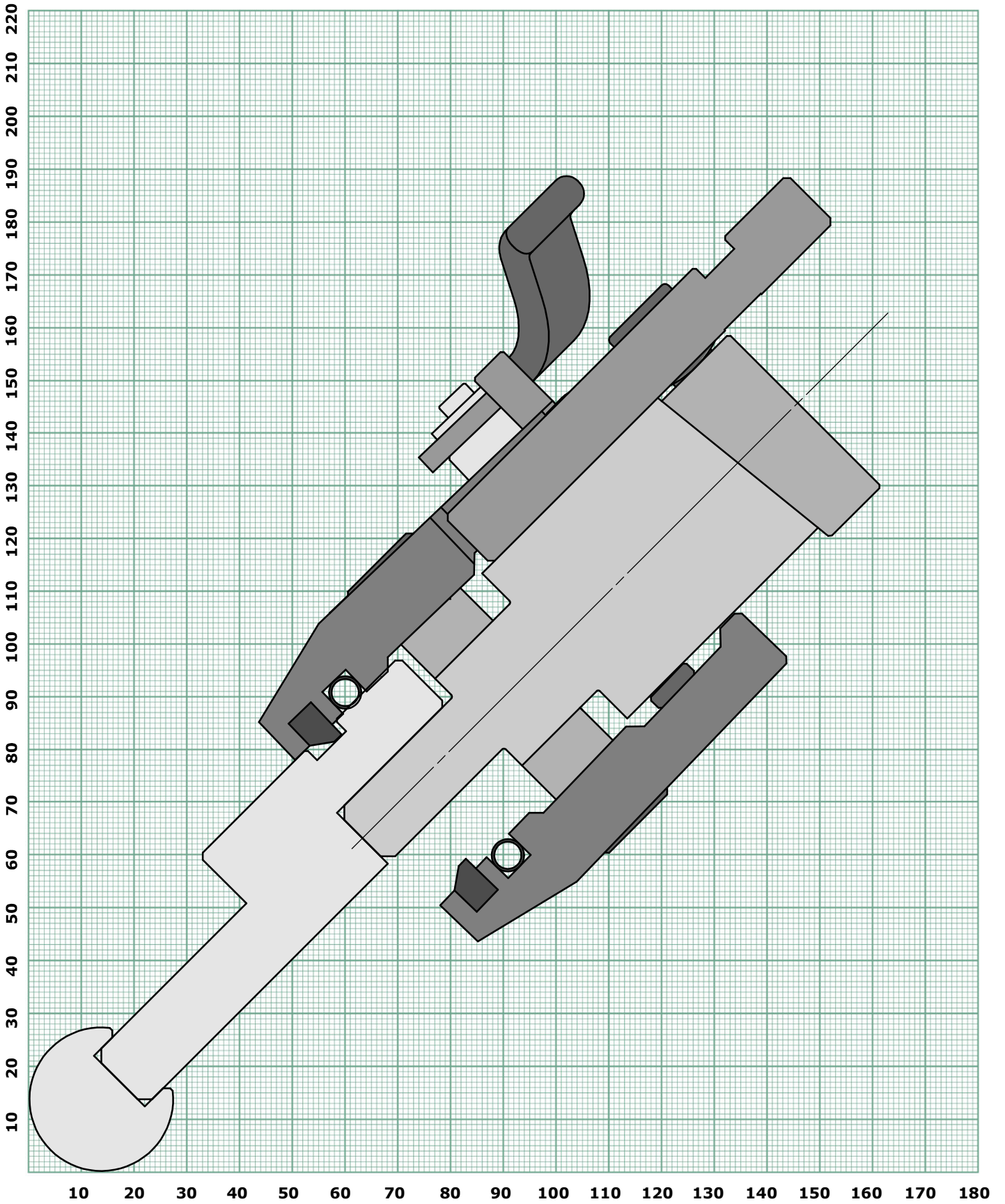

R15 Ruller with EH015 Holder

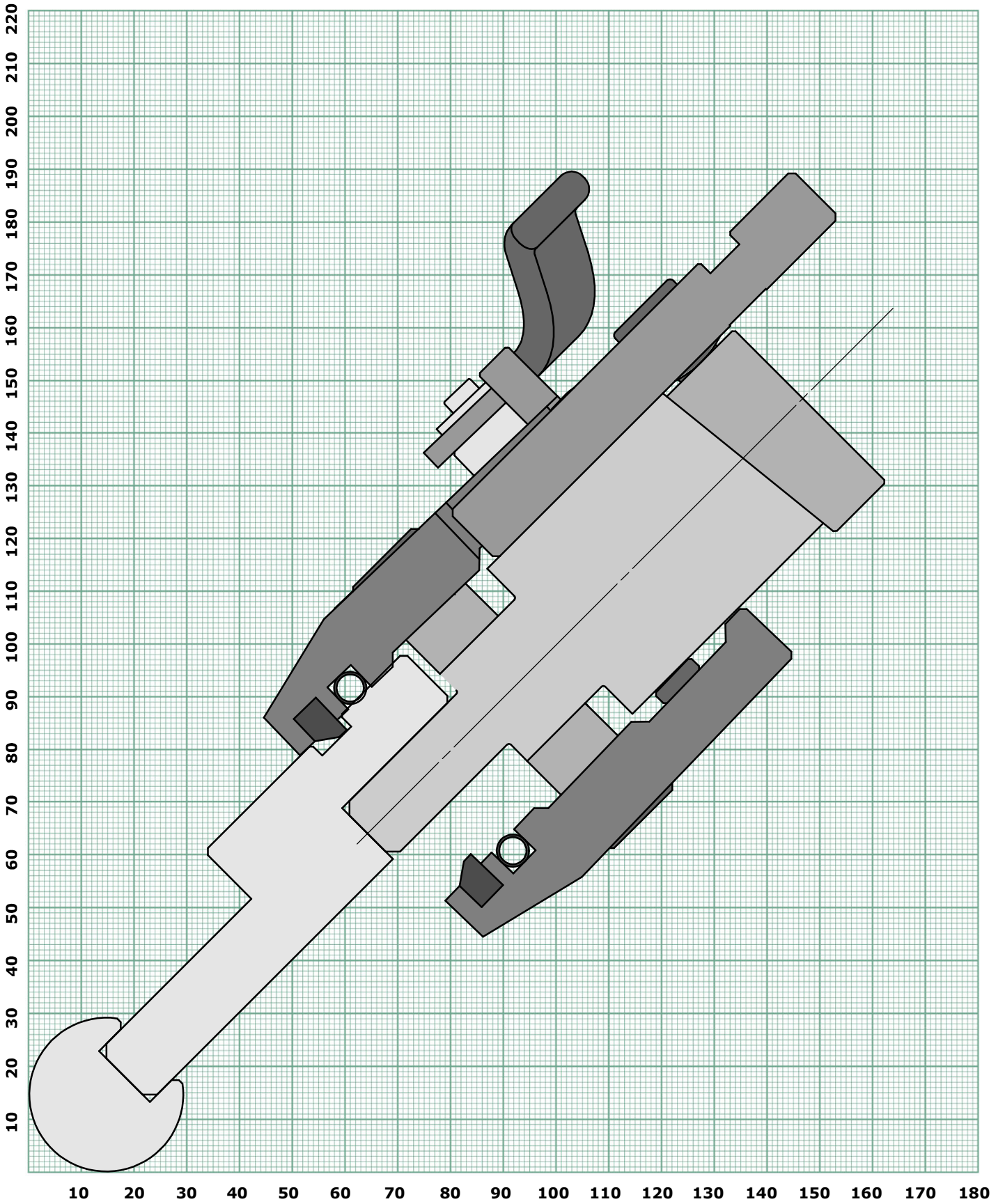

R16 Ruller with EH015 Holder

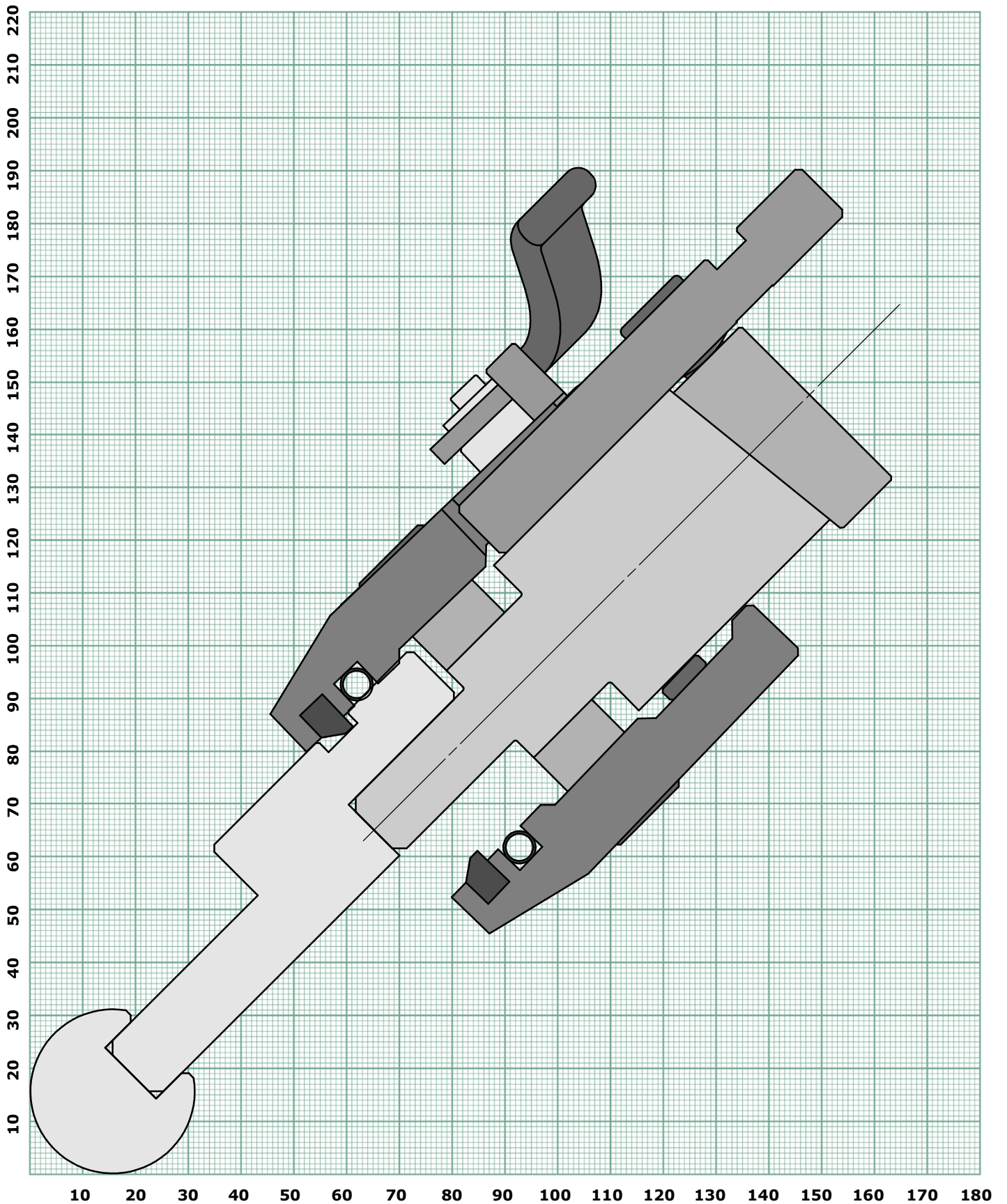

R17,5 Ruller with EH015 Holder

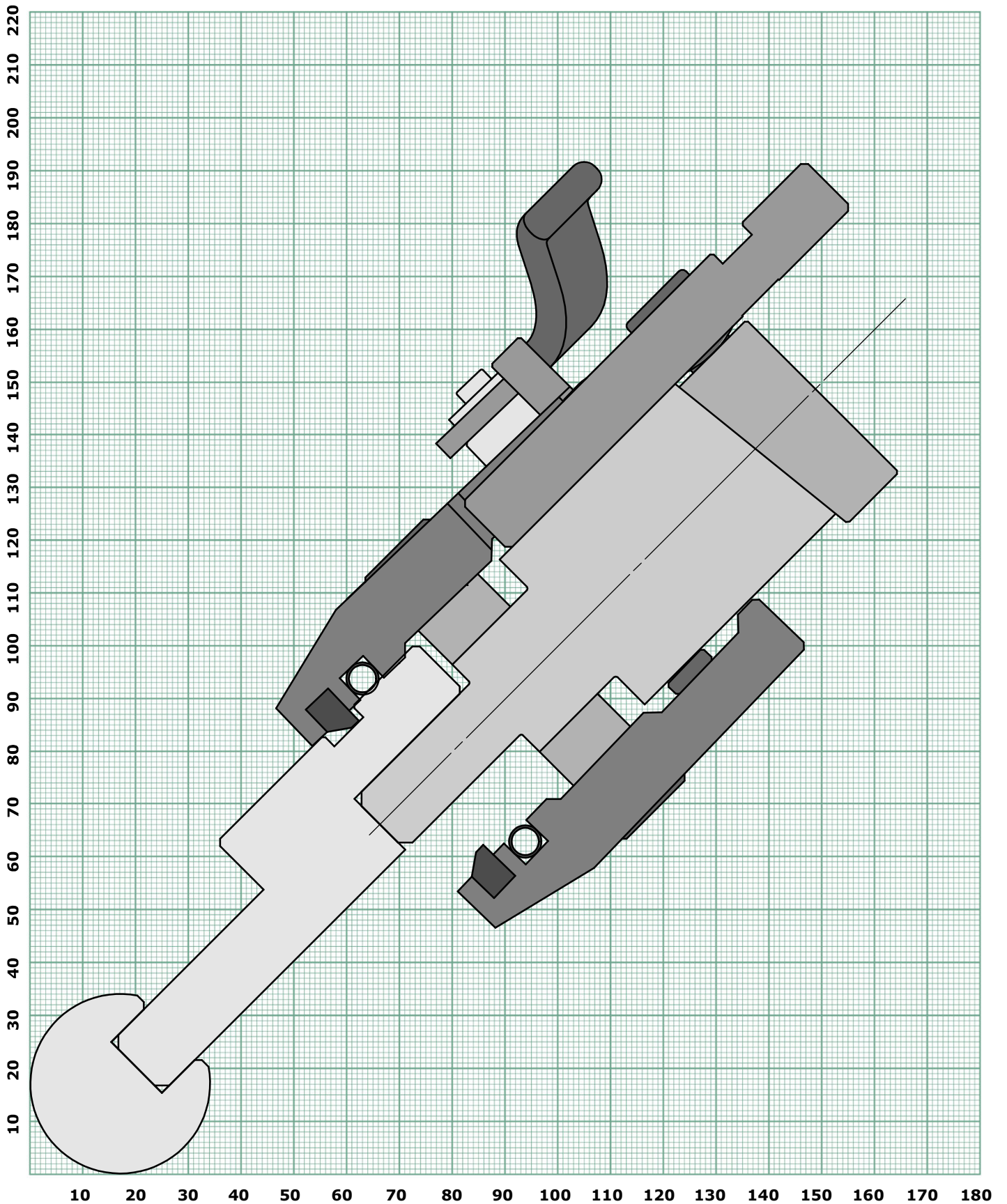

R20 Ruller with EH015 Holder

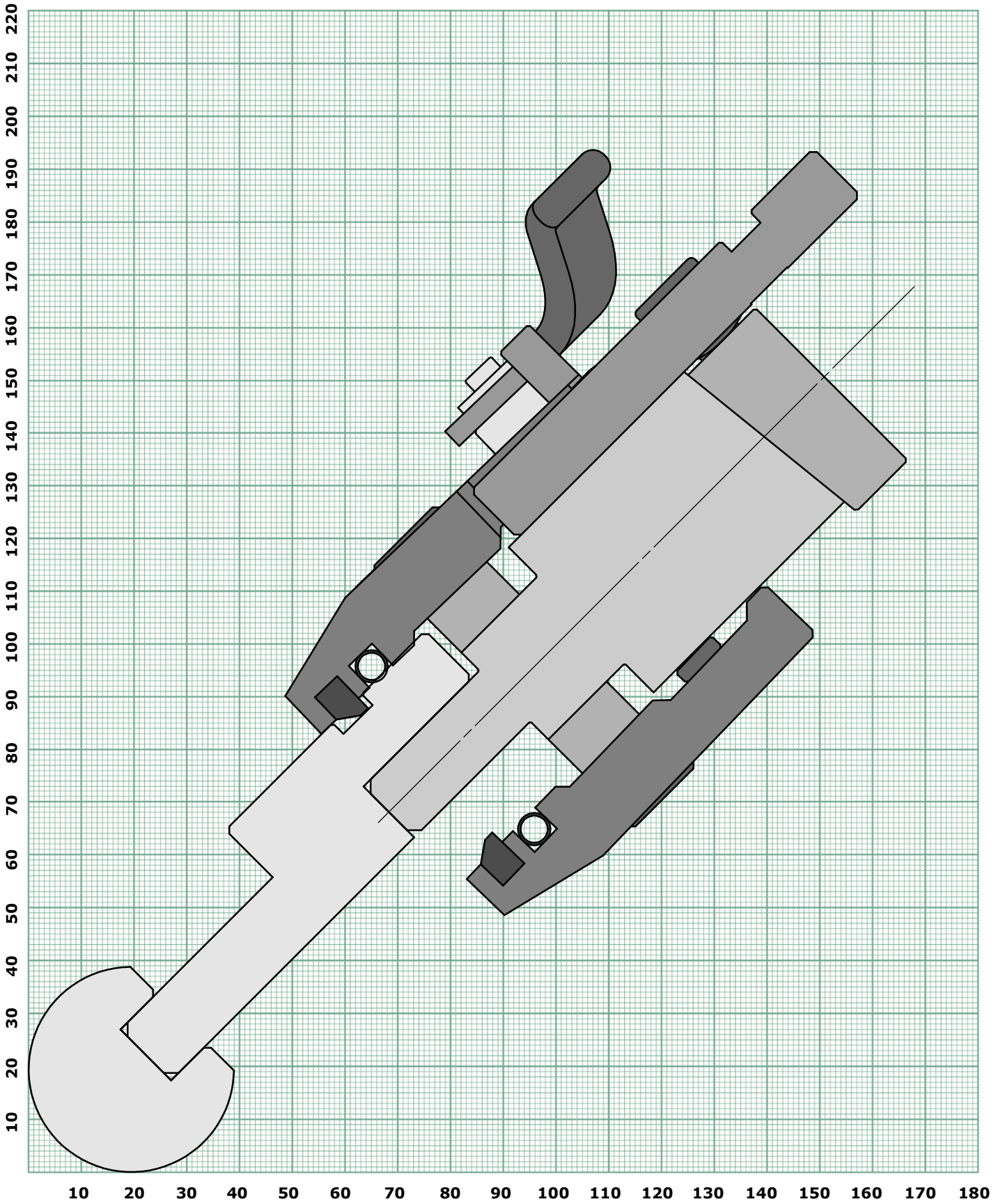

R22,5 Ruller with EH015 Holder

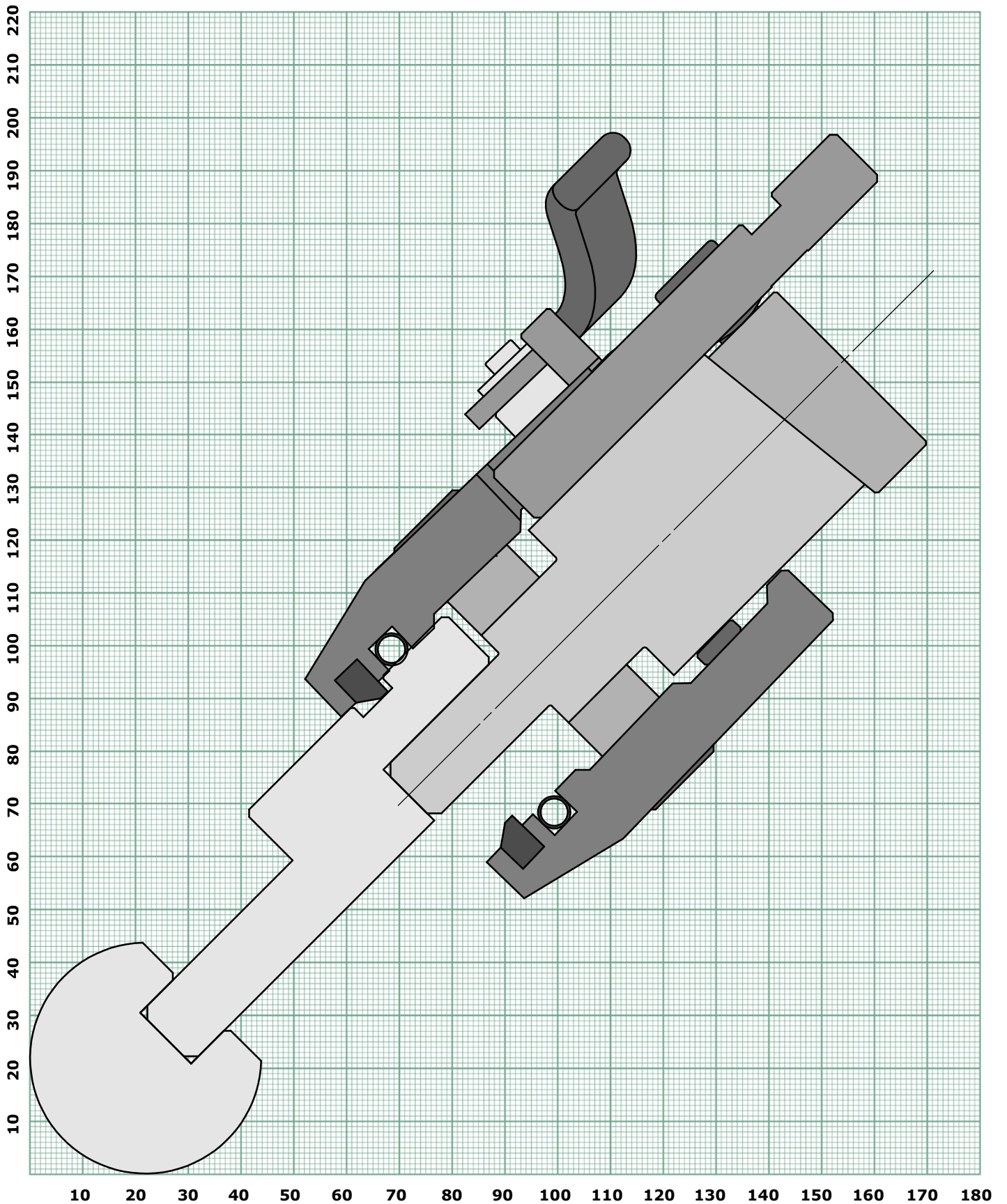

R25 Ruller with EH015 Holder

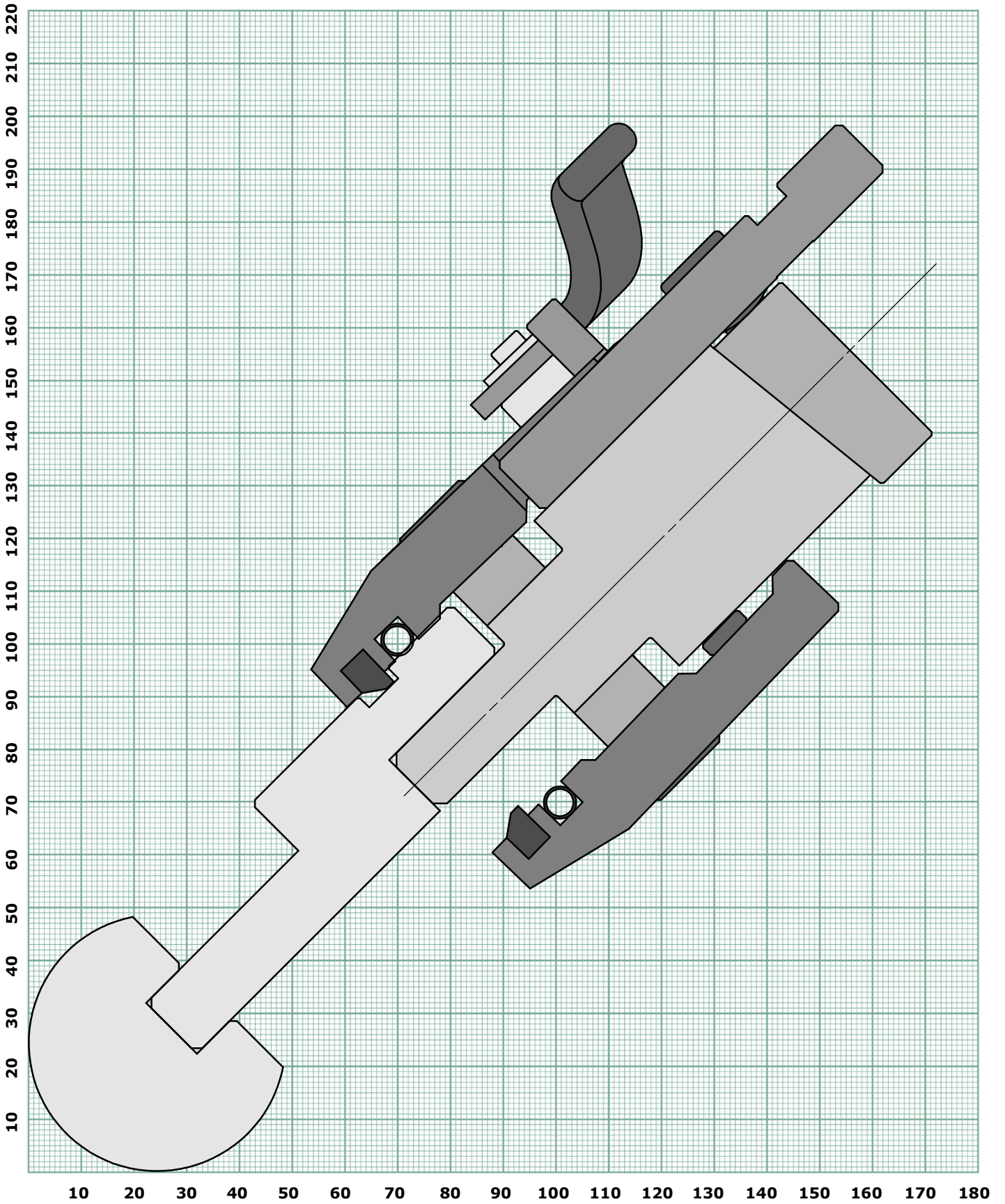

R30 Ruller with EH015 Holder

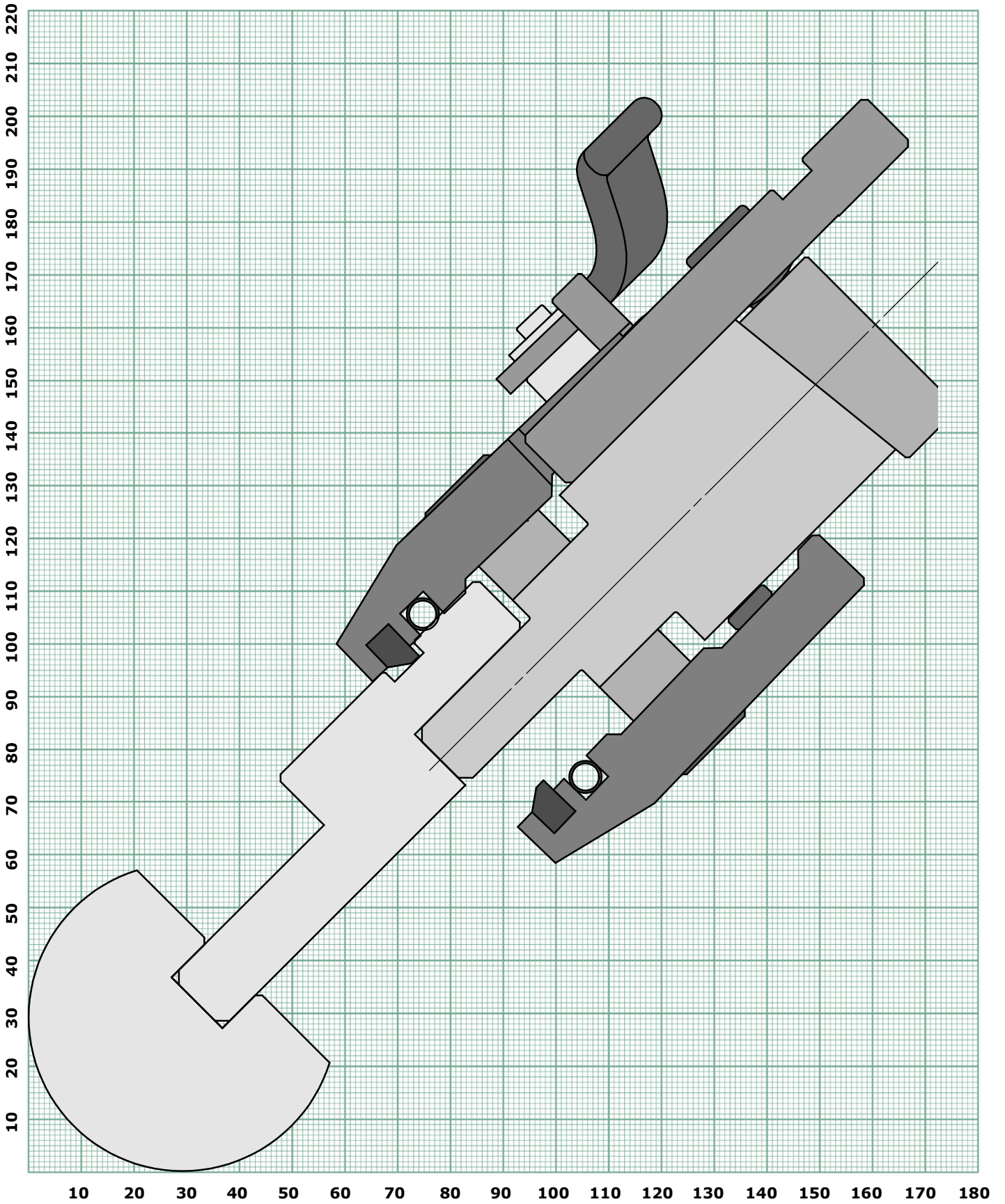

R35 Ruller with EH015 Holder

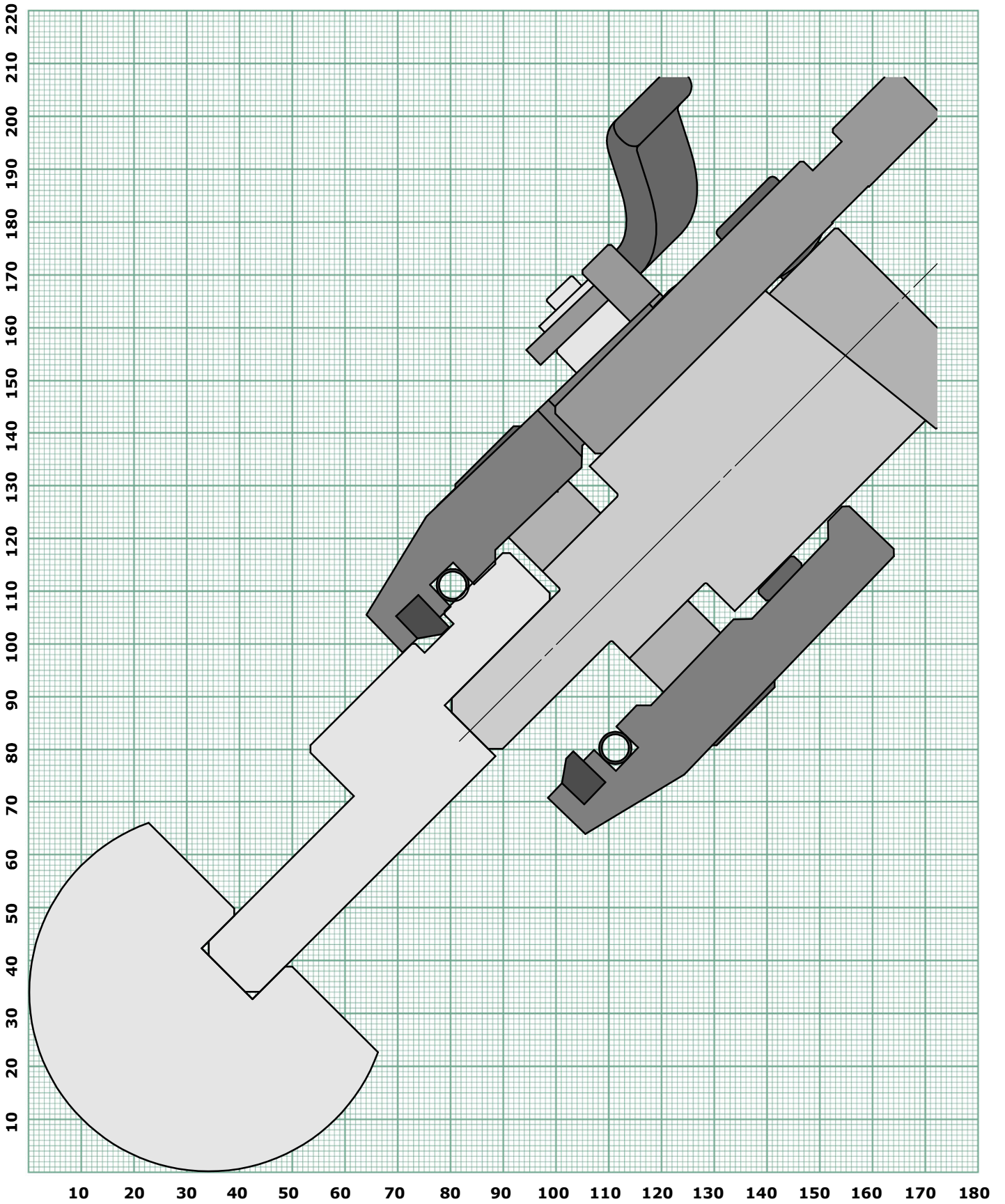

R40 Ruller with EH015 Holder

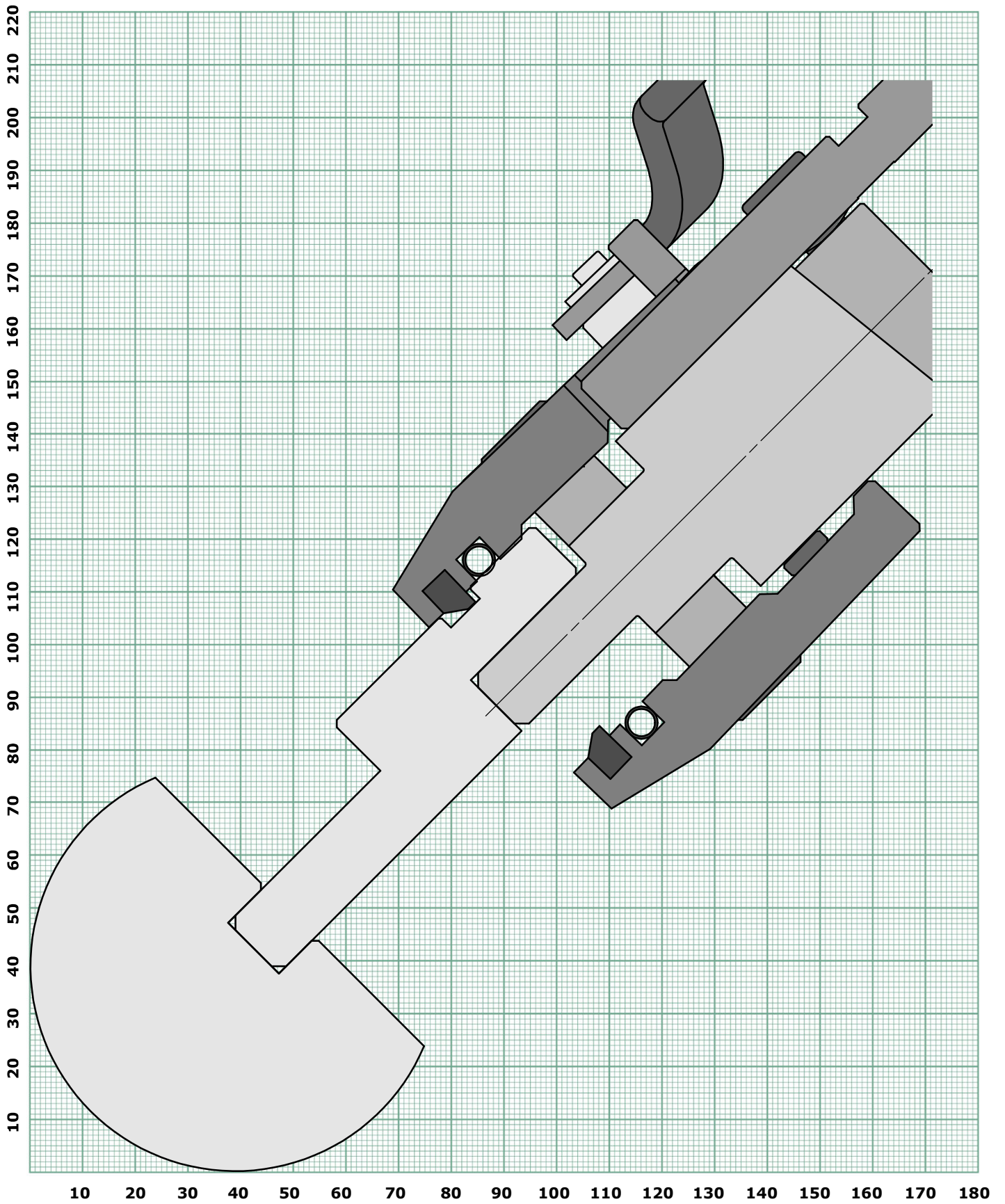

R45 Ruller with EH015 Holder

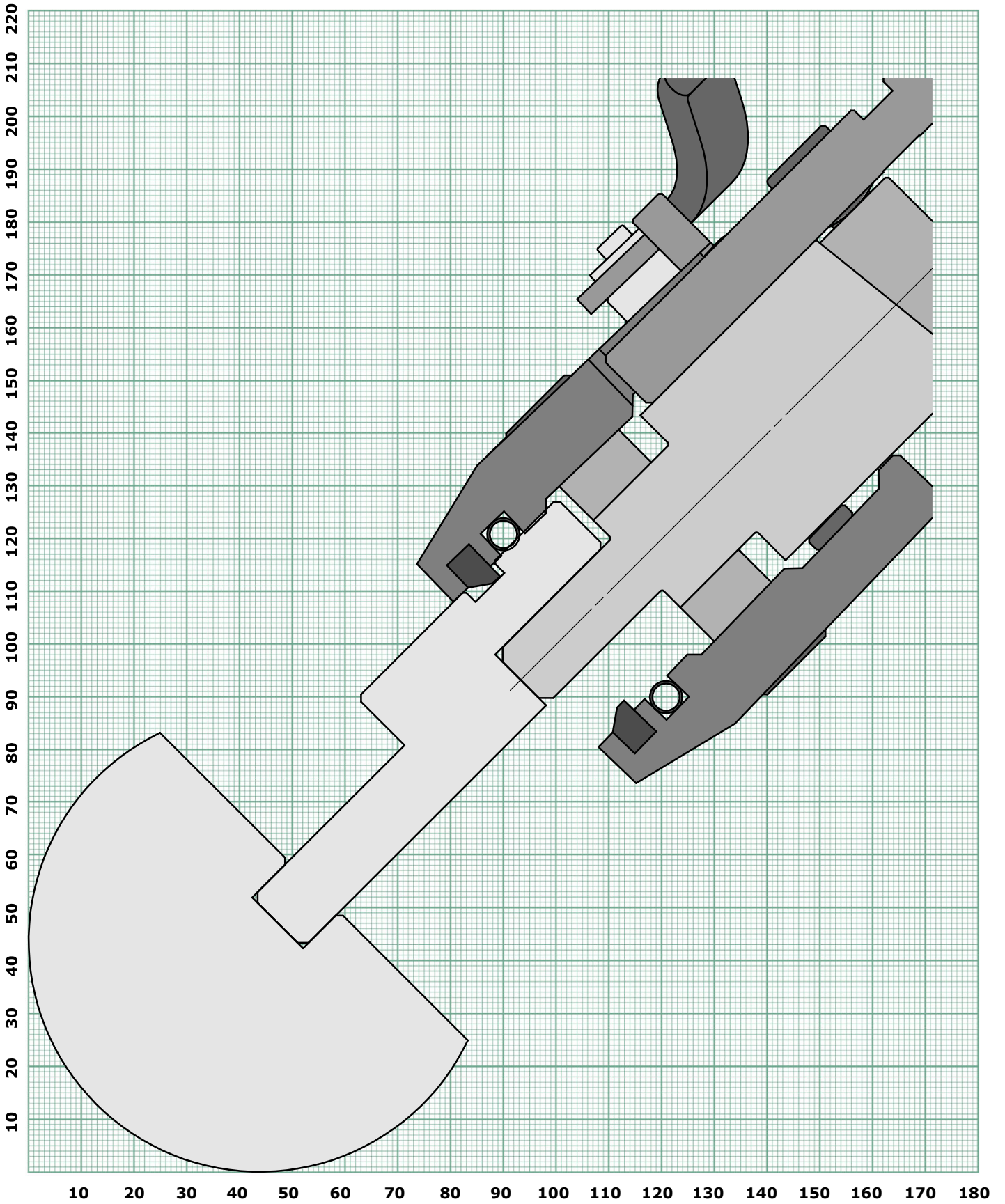

R50 Ruller with EH015 Holder

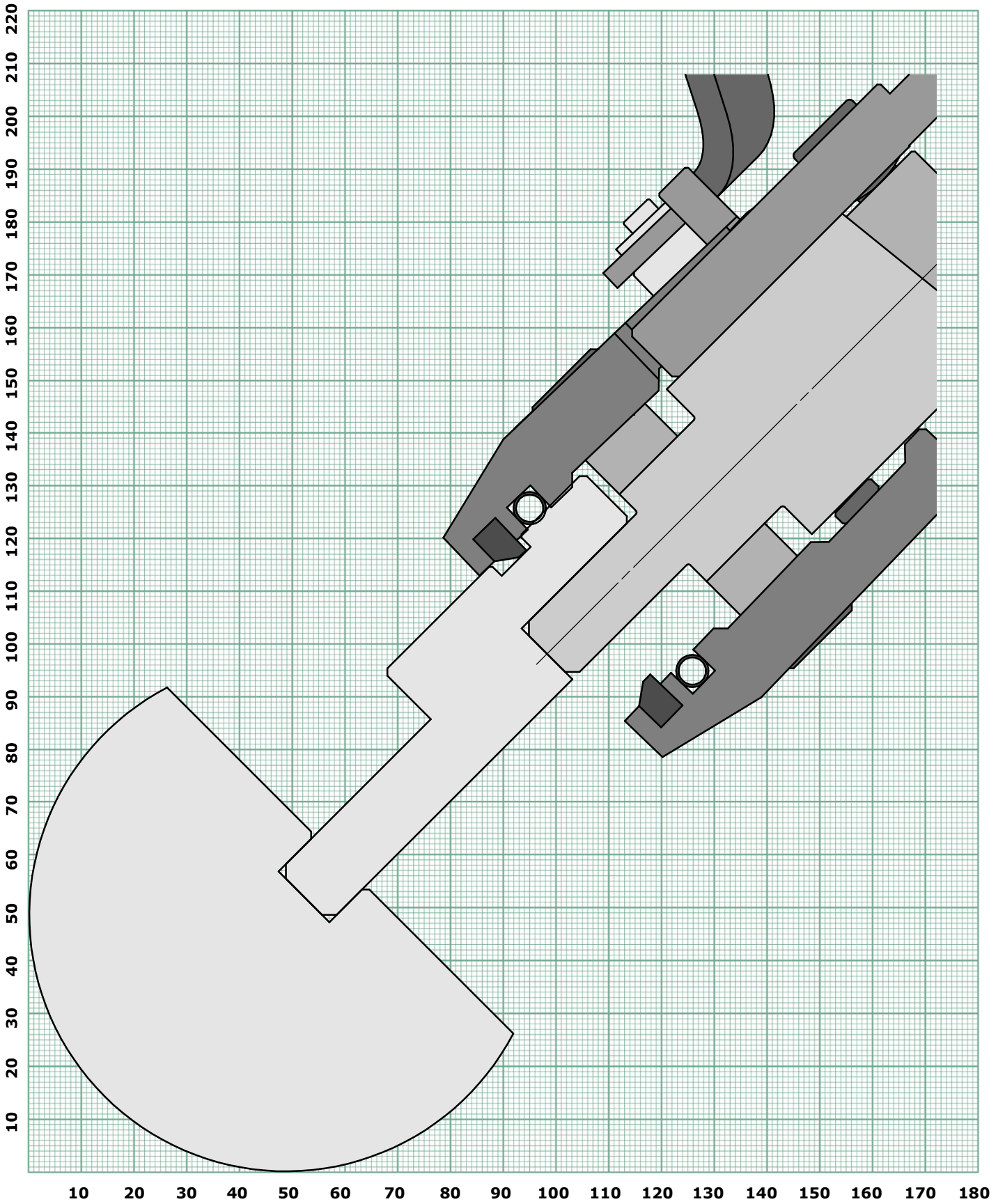

R7 Ruller with EH016 Holder

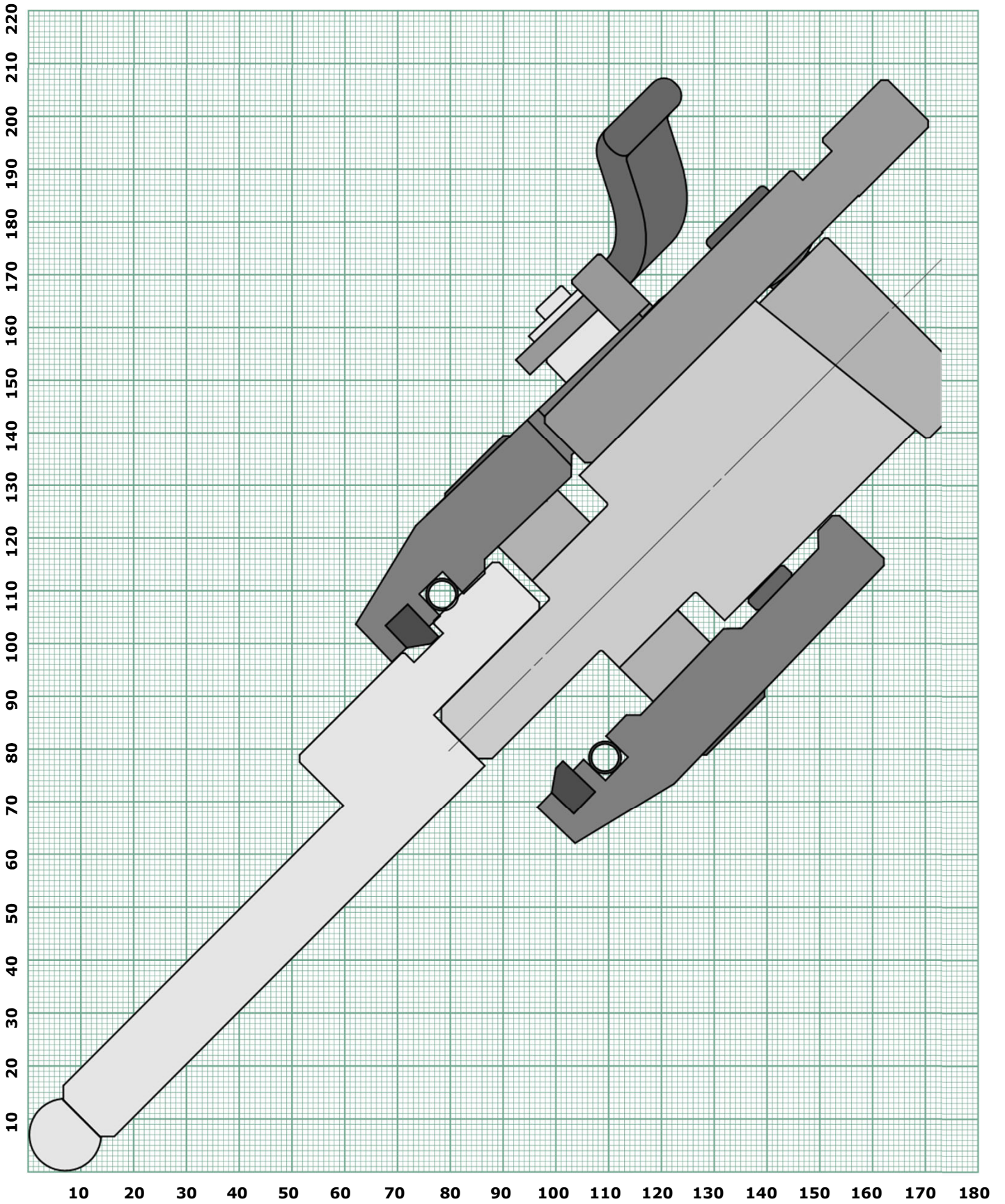

R8 Ruller with EH016 Holder

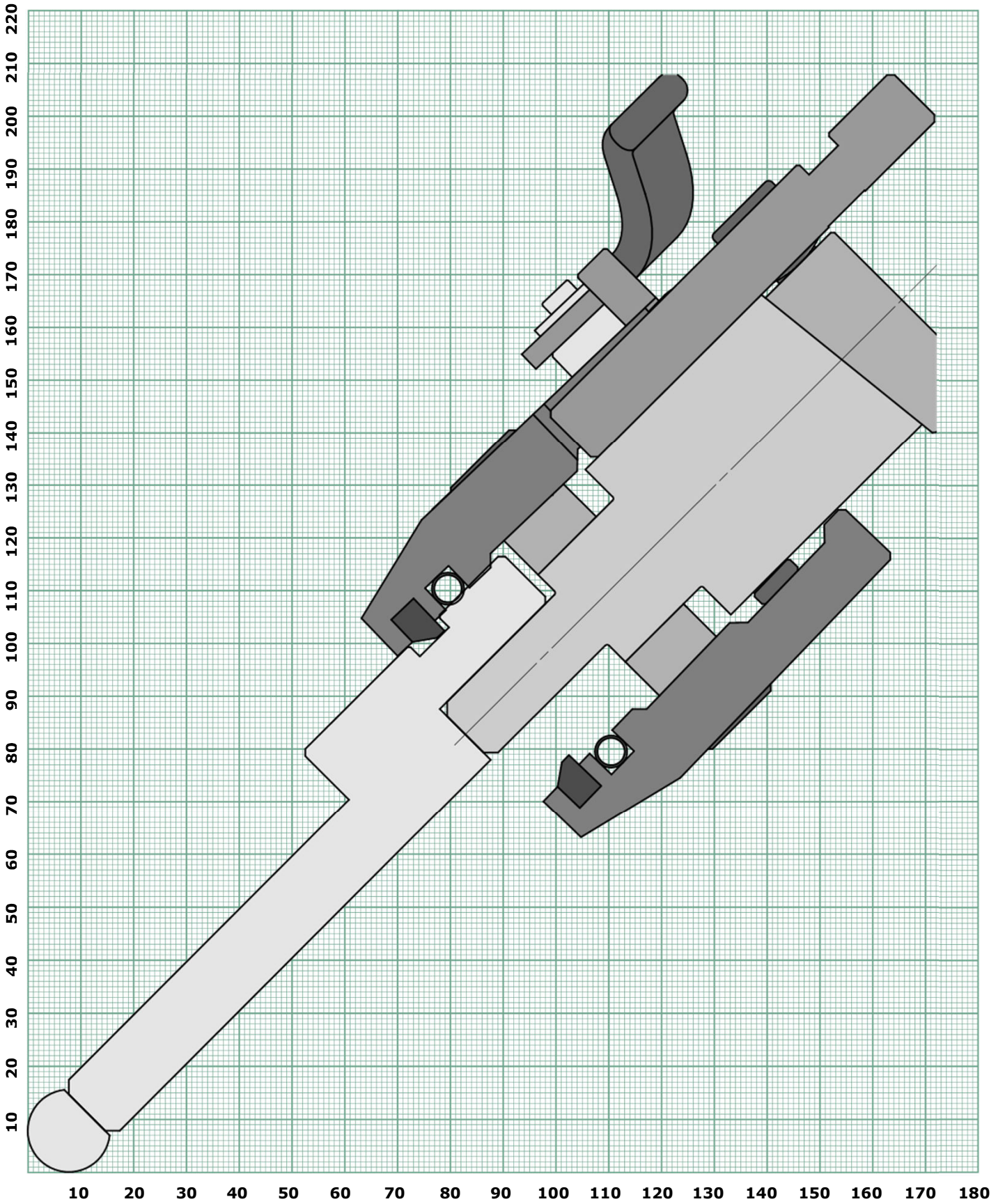

R9 Ruller with EH016 Holder

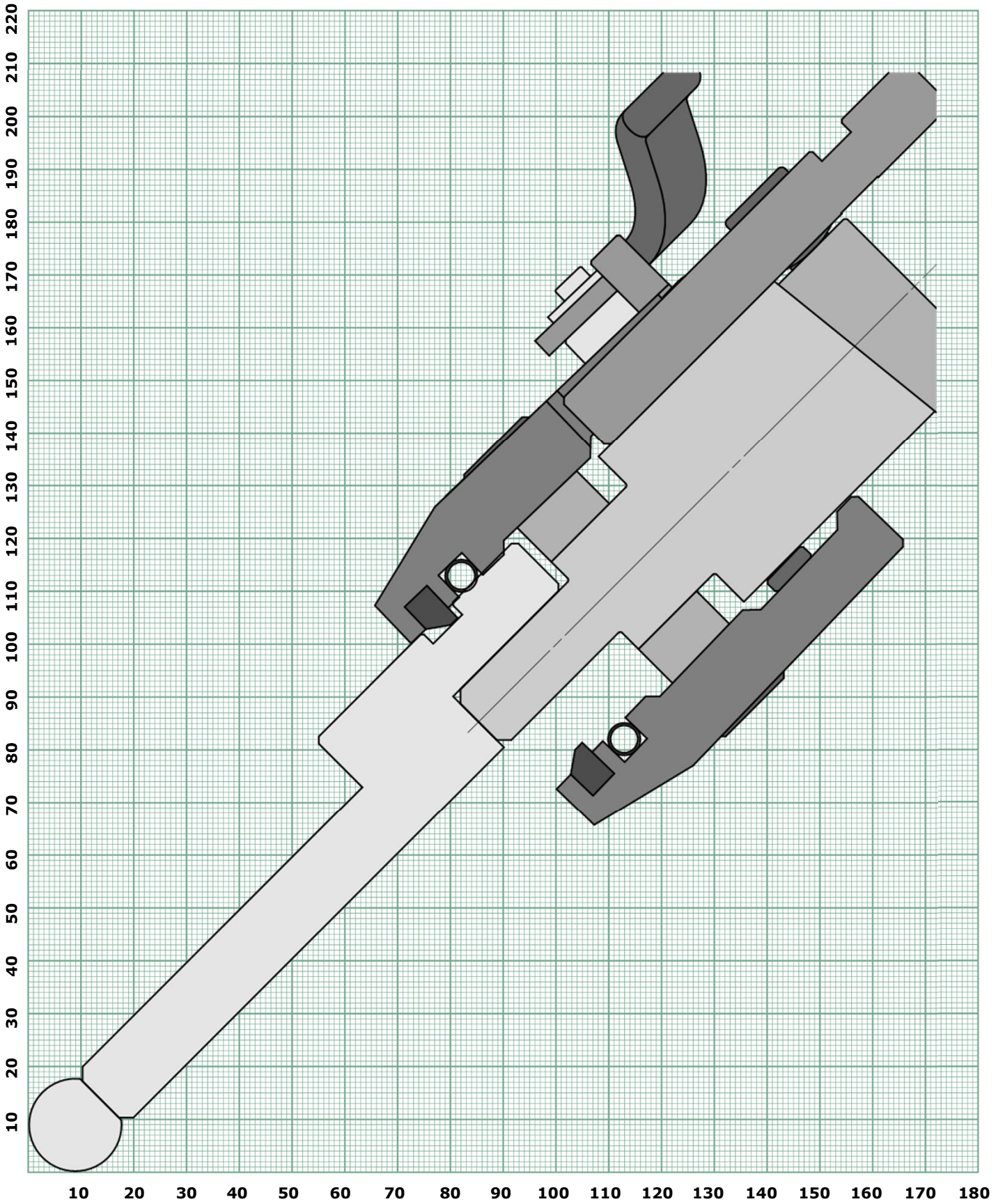

R10 Ruller with EH016 Holder

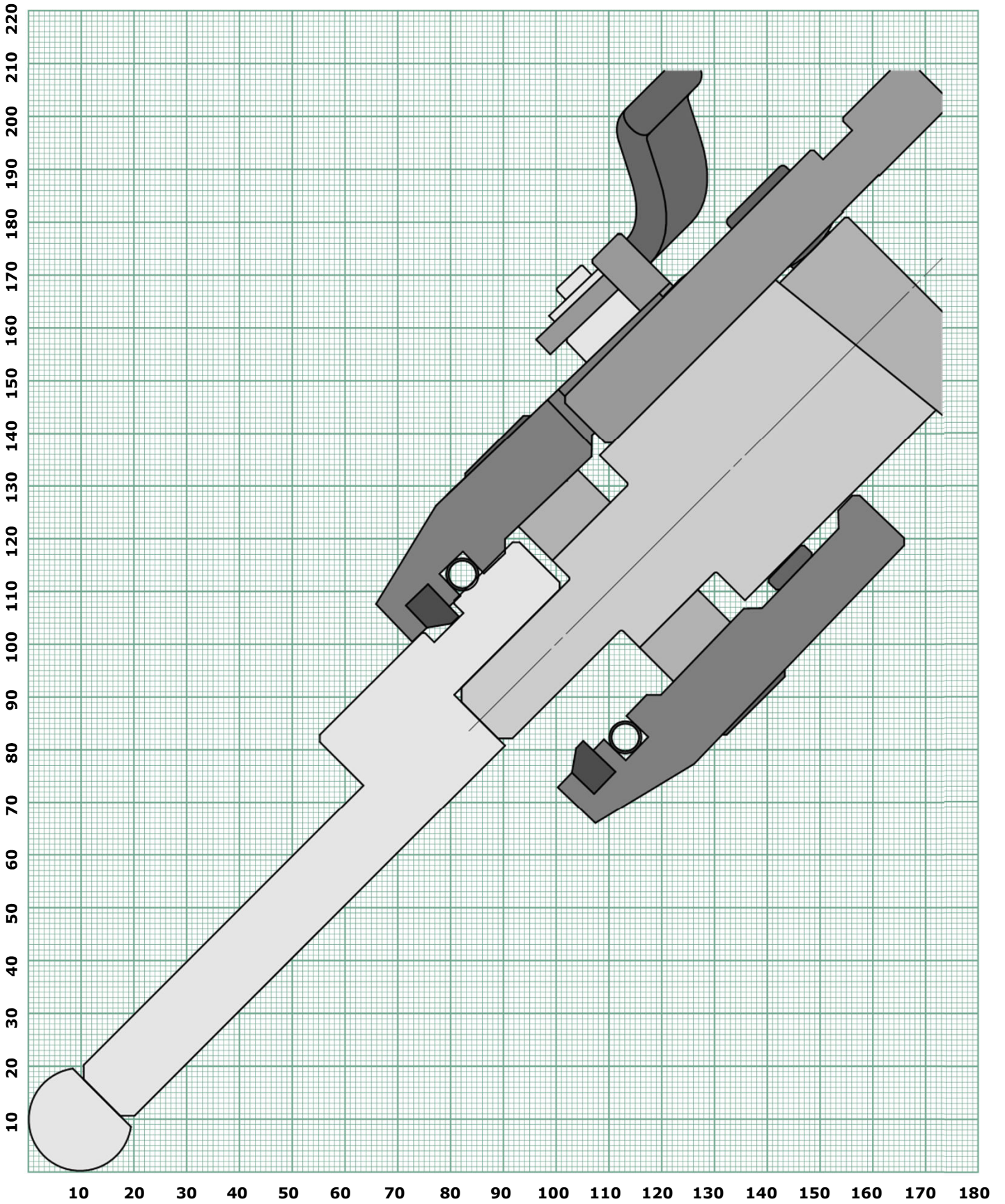

R11 Ruller with EH016 Holder

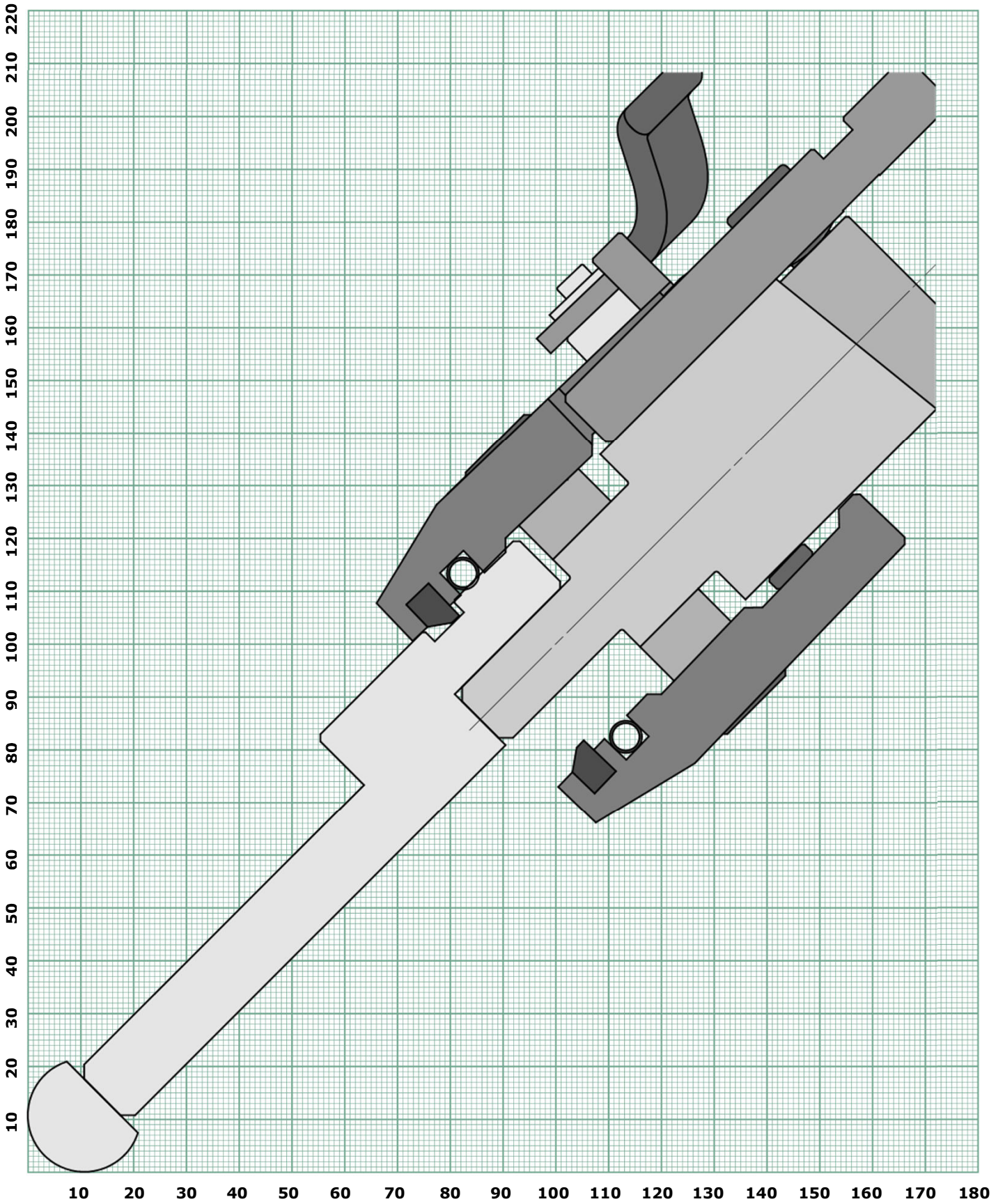

R12,5 Ruller with EH016 Holder

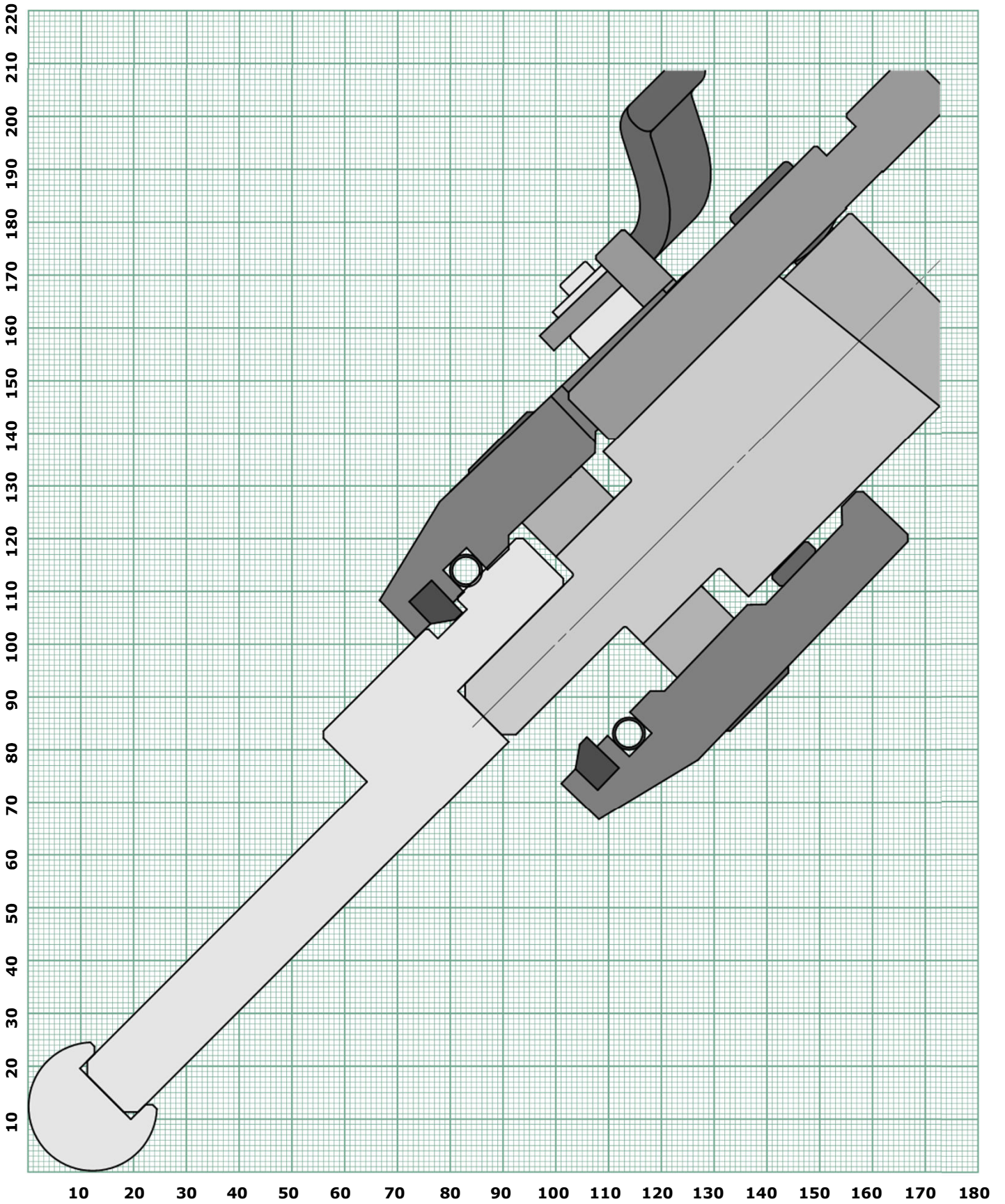

R14 Ruller with EH016 Holder

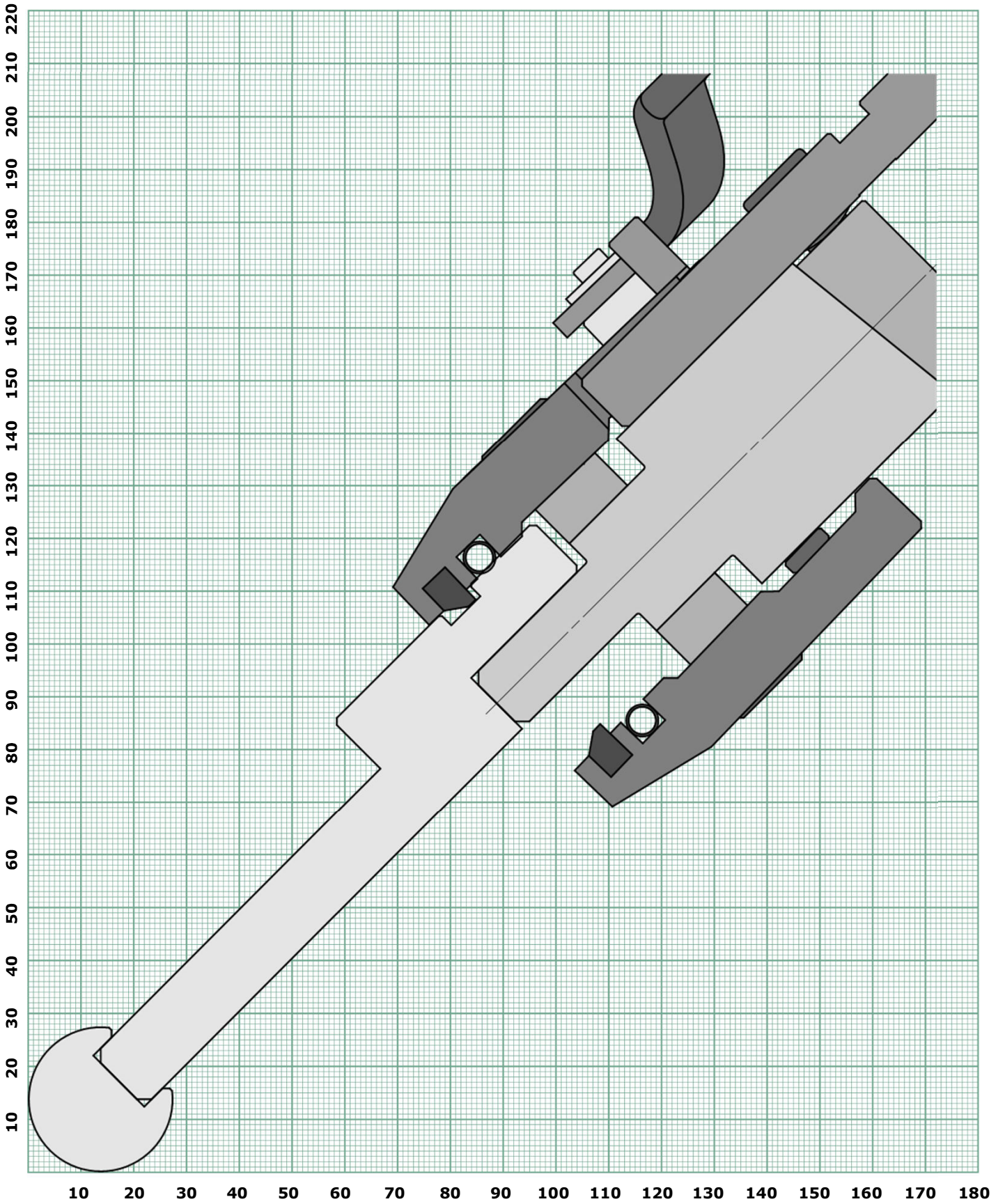

R15 Ruller with EH016 Holder

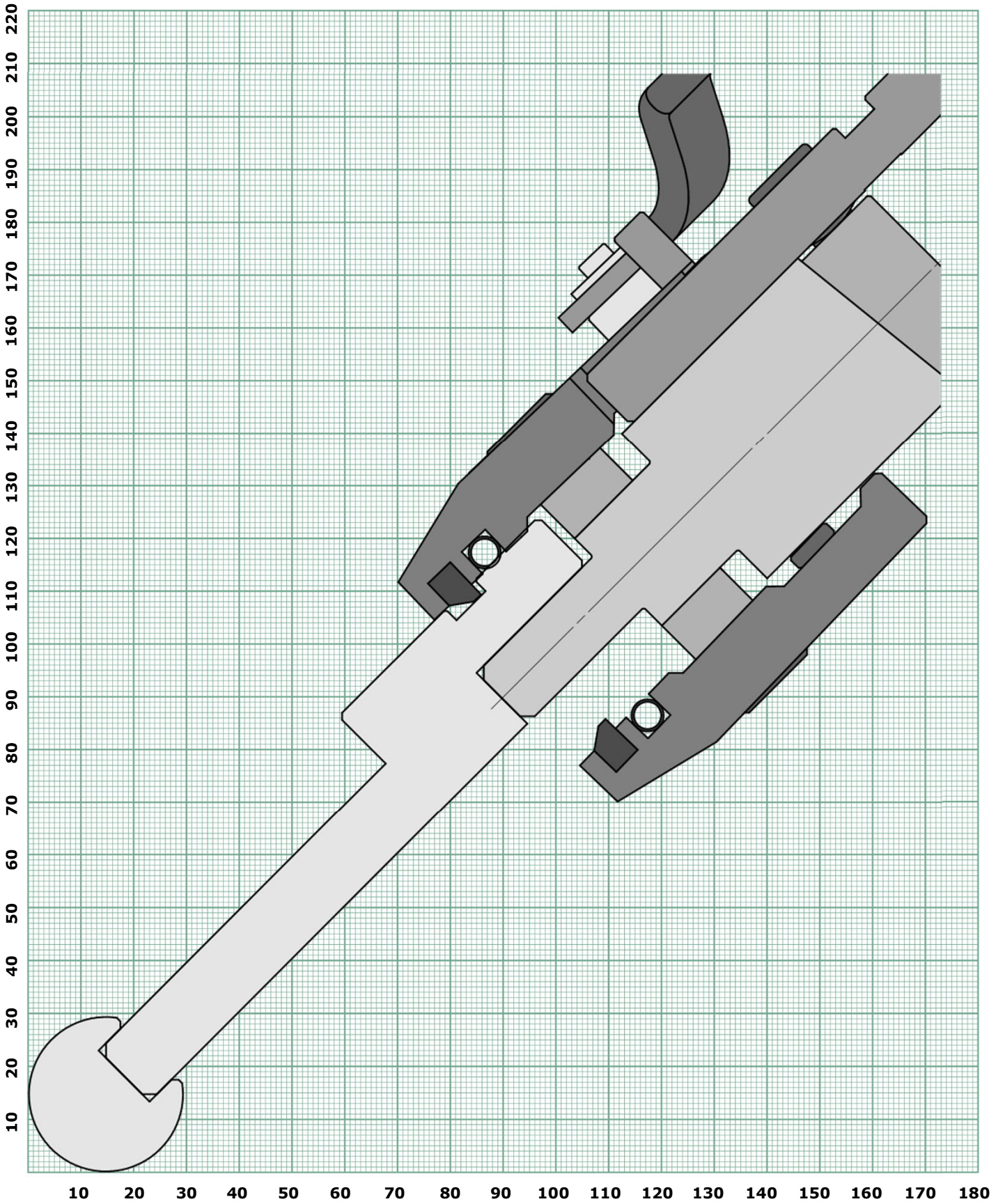

R16 Ruller with EH016 Holder

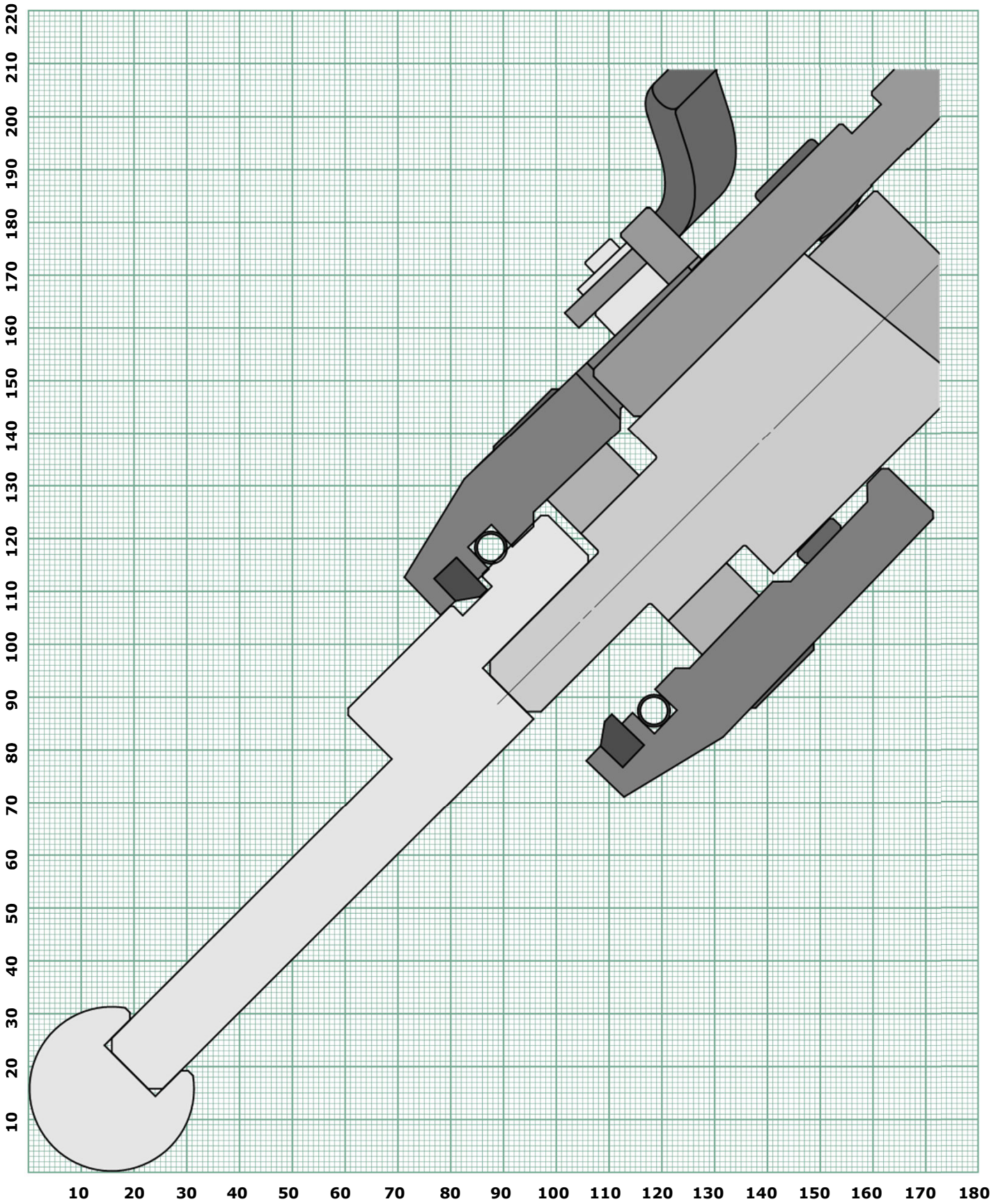

R17,5 Ruller with EH016 Holder

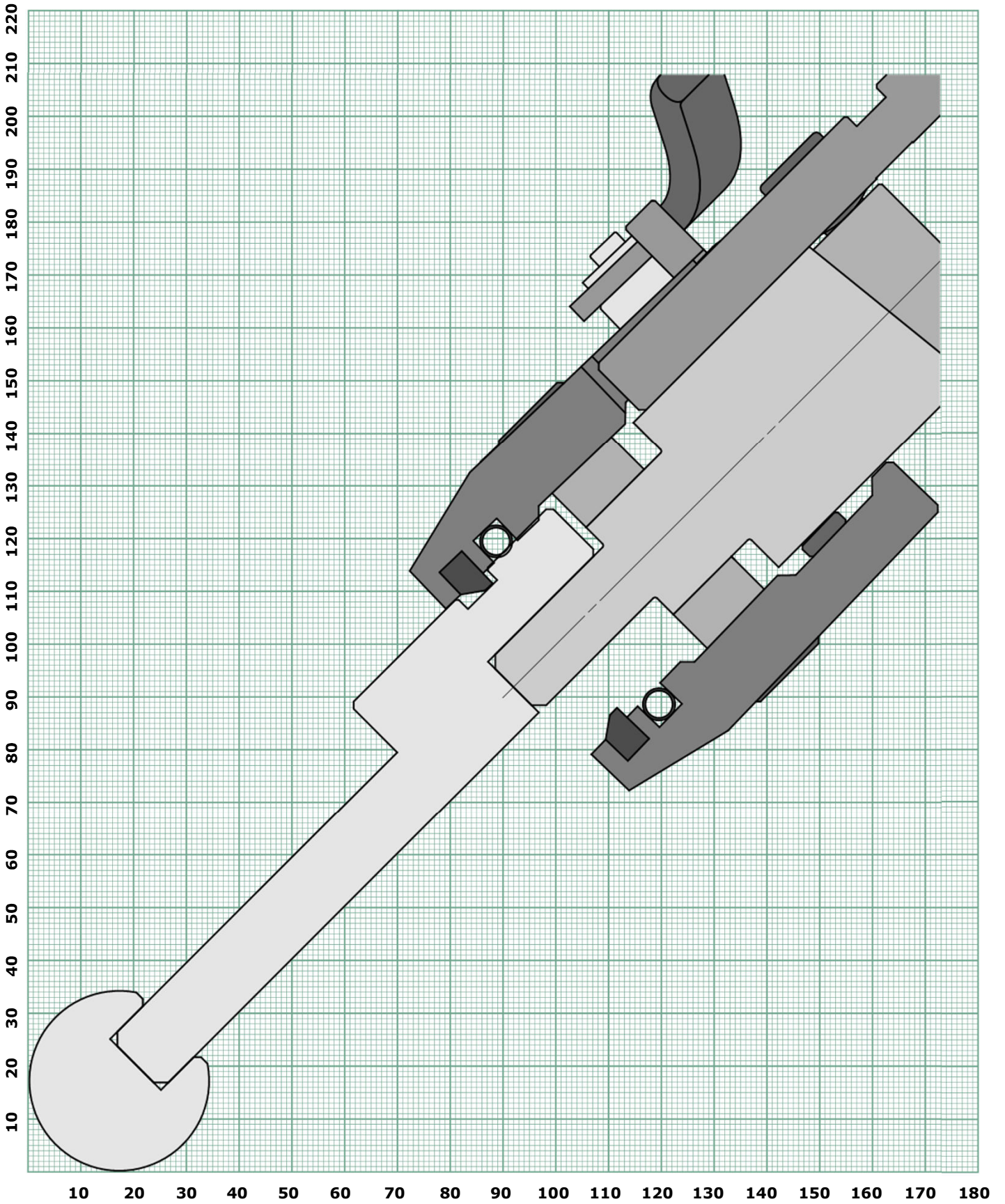

R20 Ruller with EH016 Holder

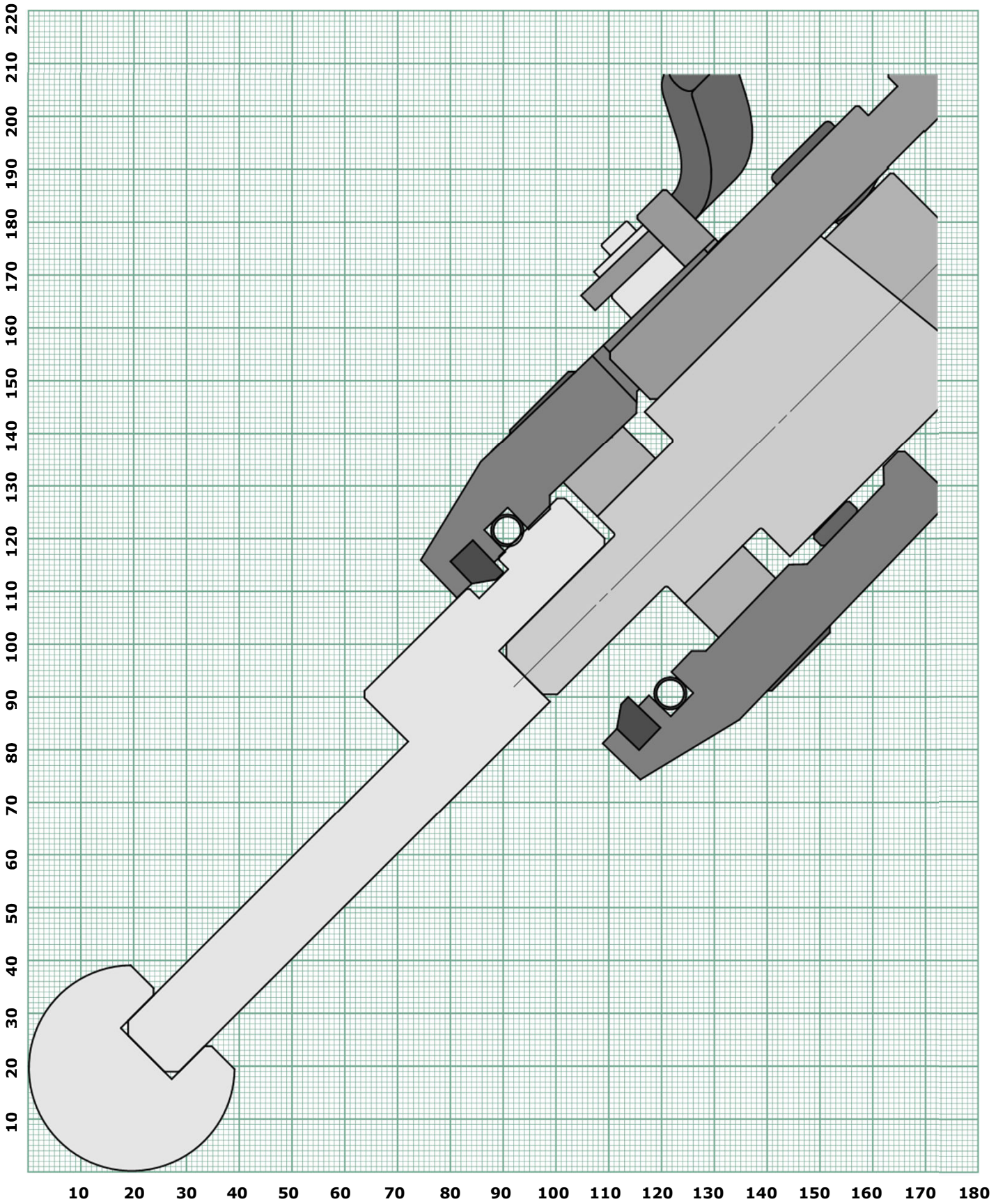

R22,5 Ruller with EH016 Holder

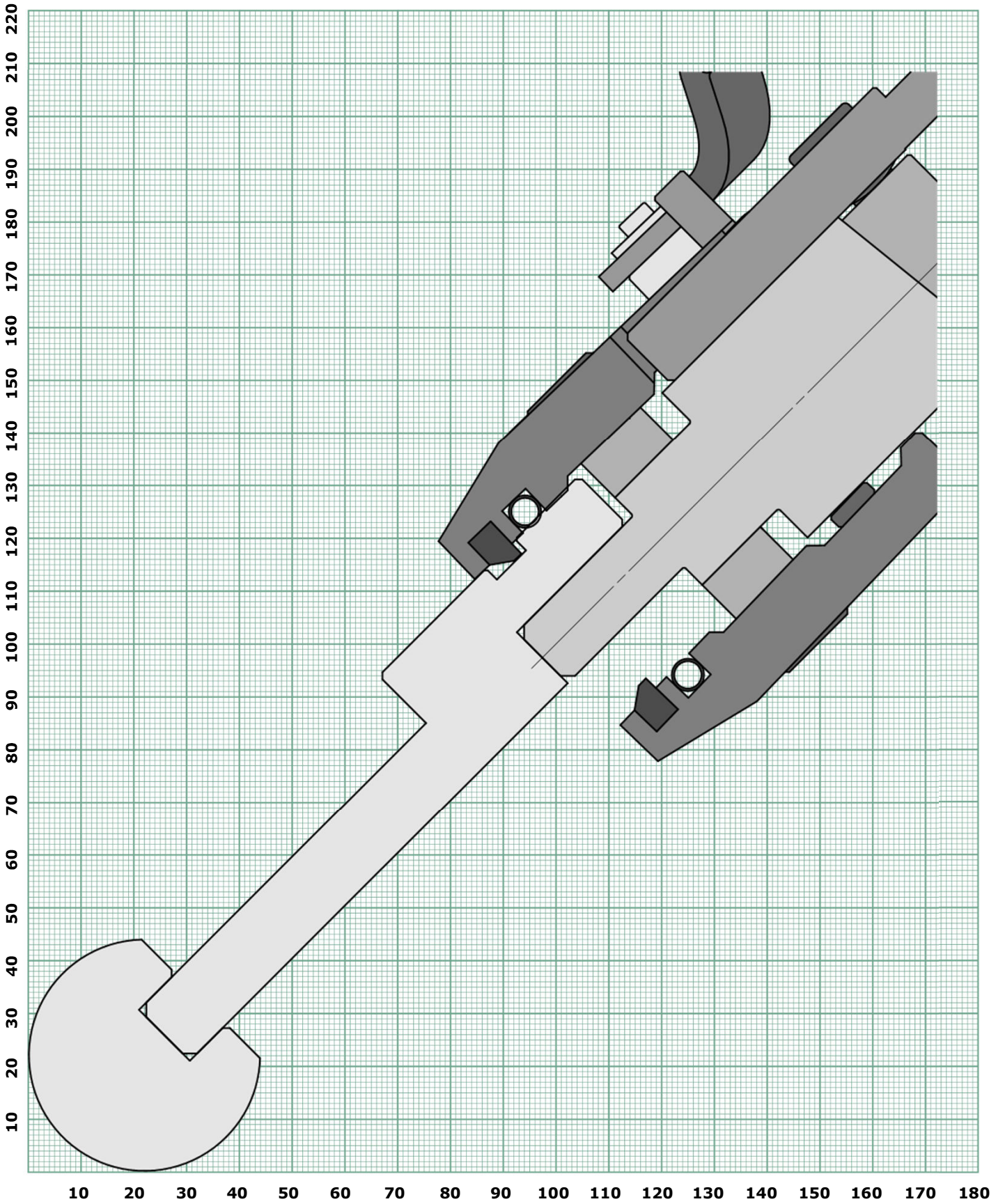

R25 Ruller with EH016 Holder

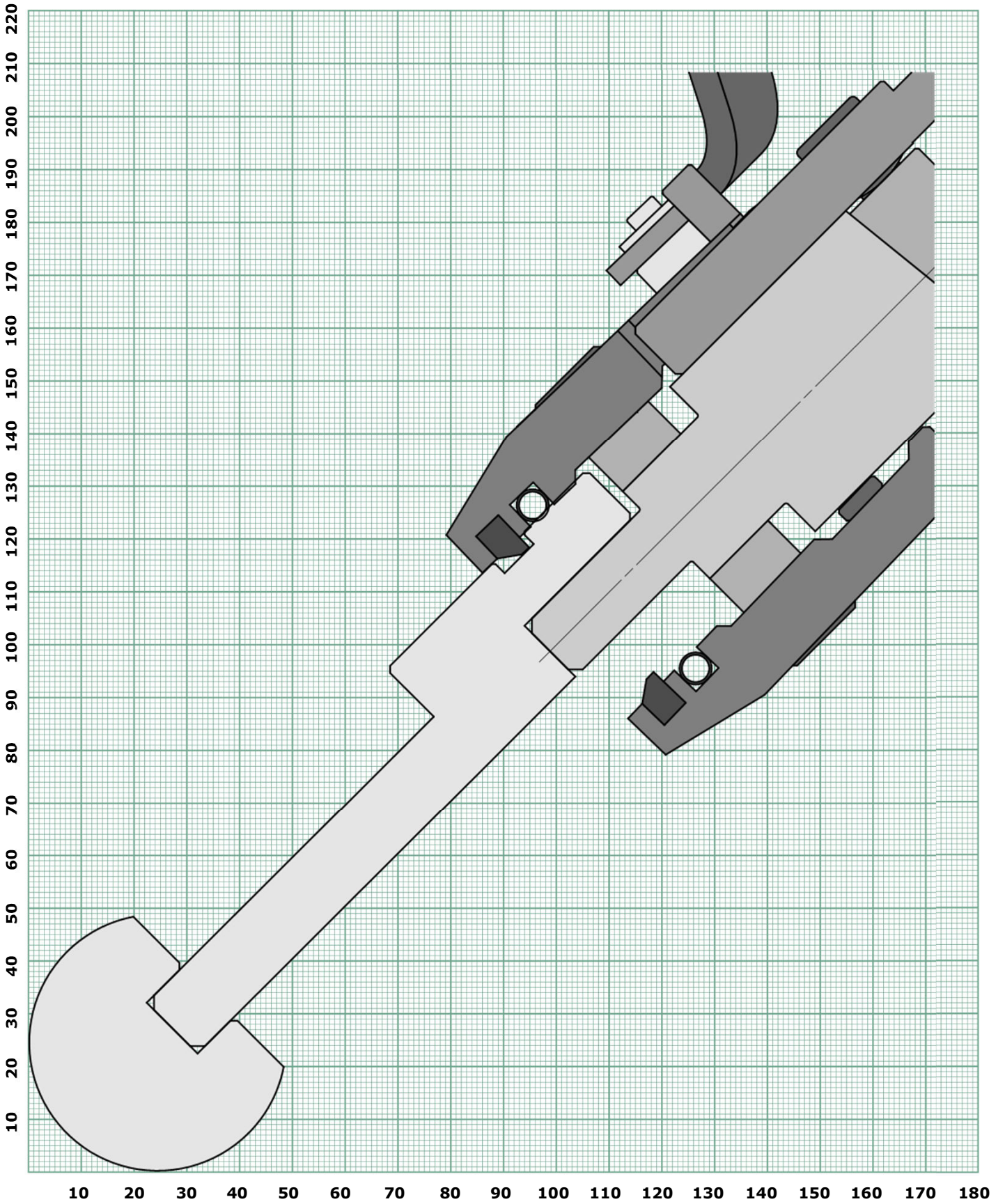

R30 Ruller with EH016 Holder

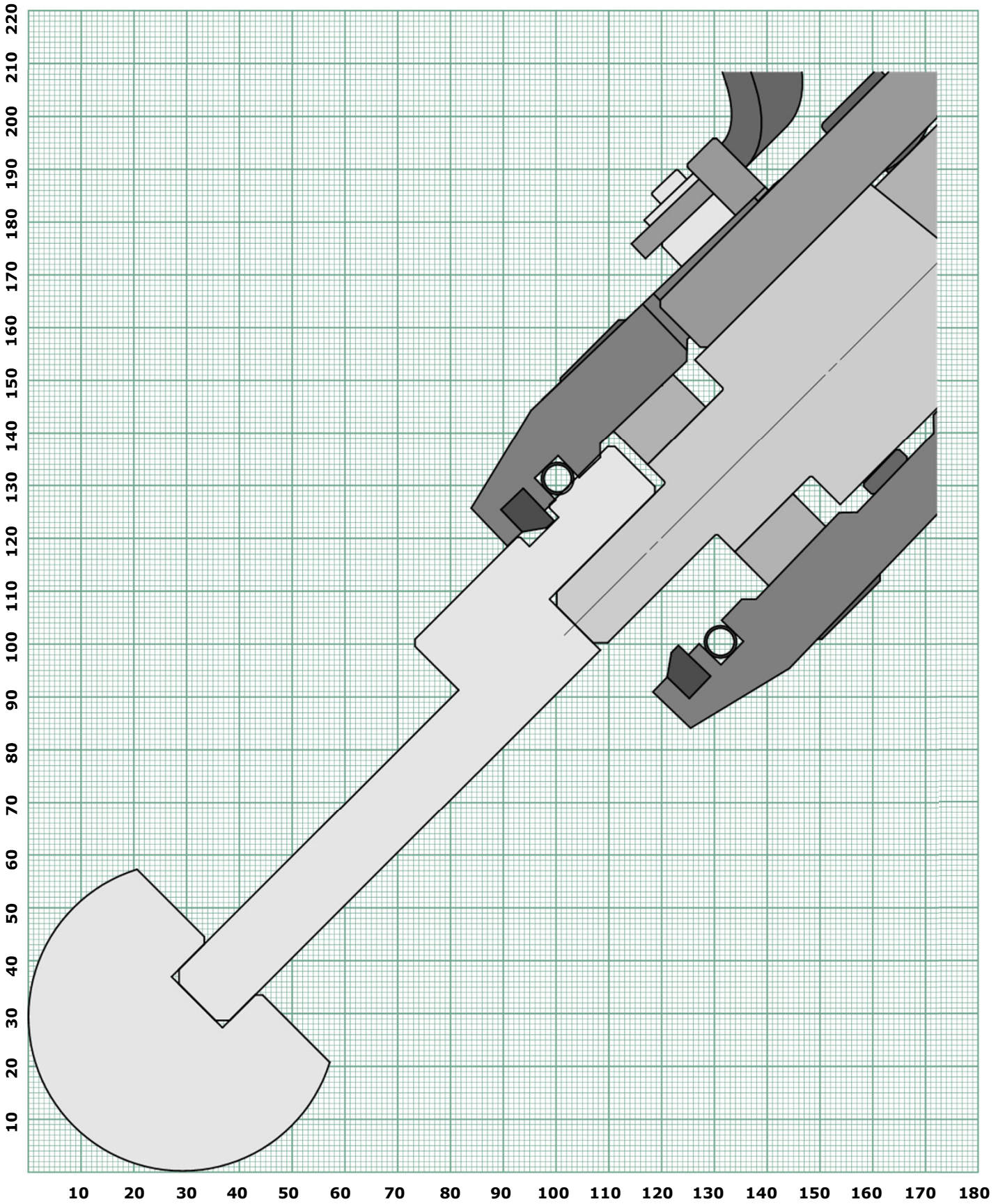

R35 Ruller with EH016 Holder

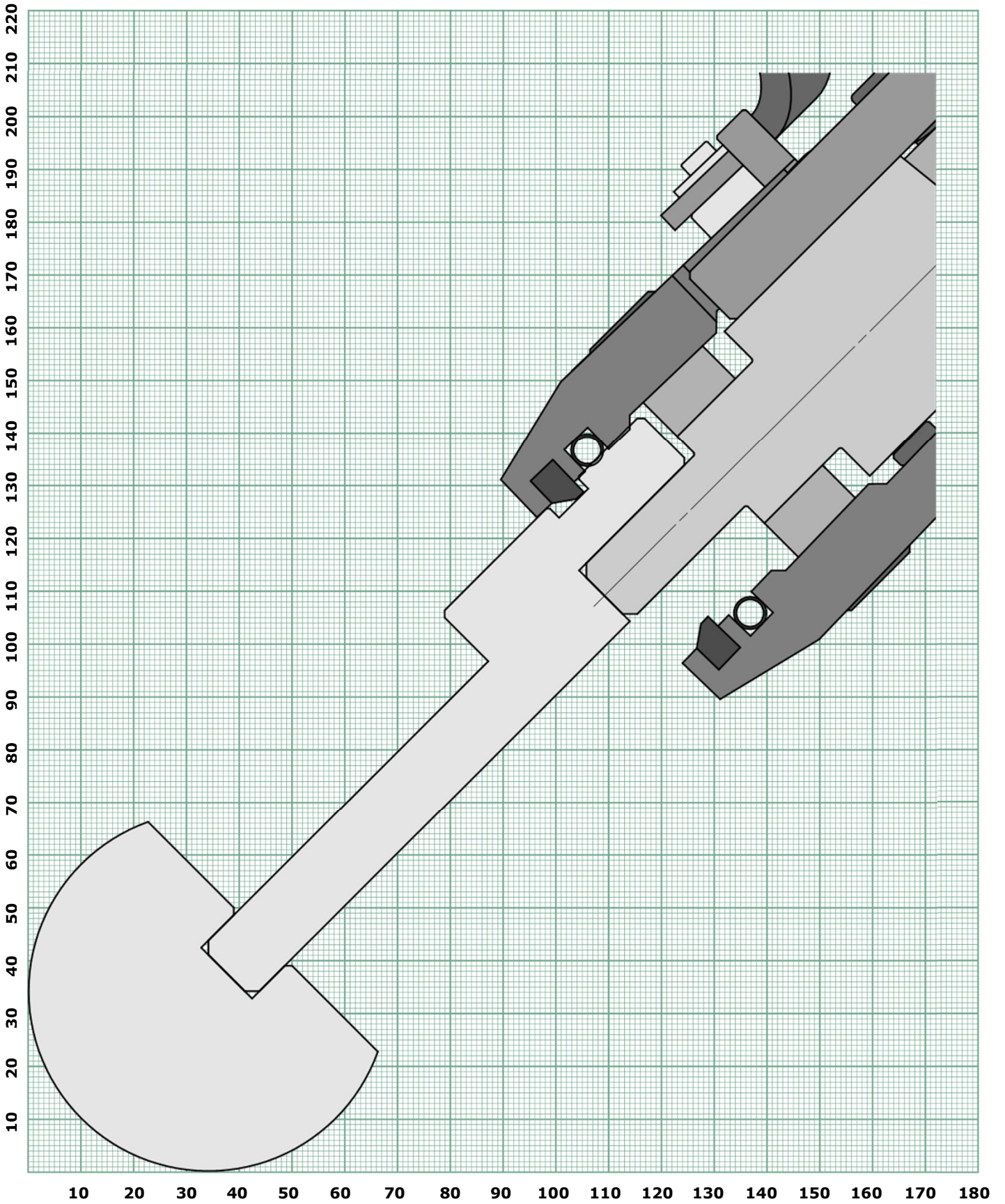

R40 Ruller with EH016 Holder

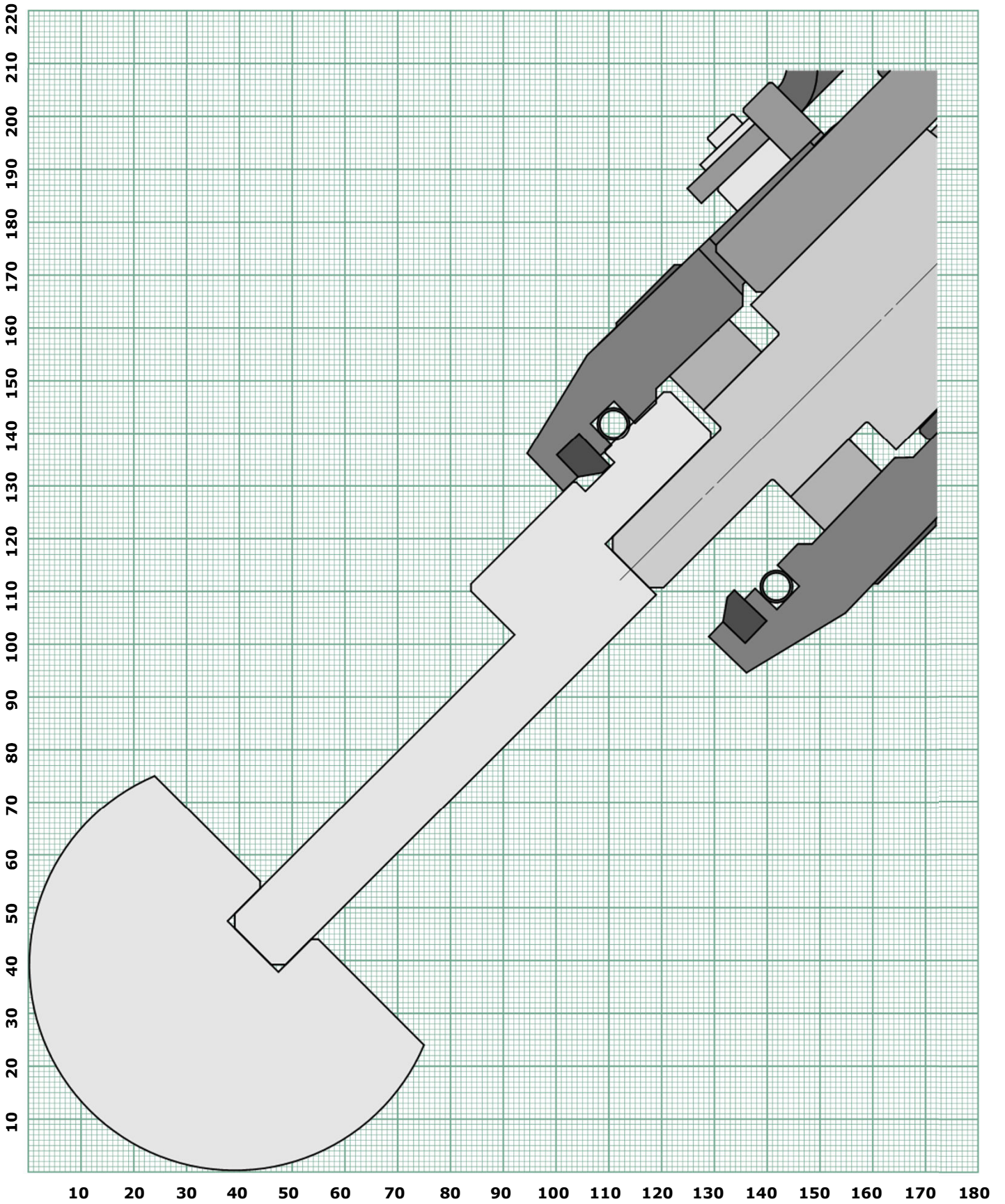

R45 Ruller with EH016 Holder

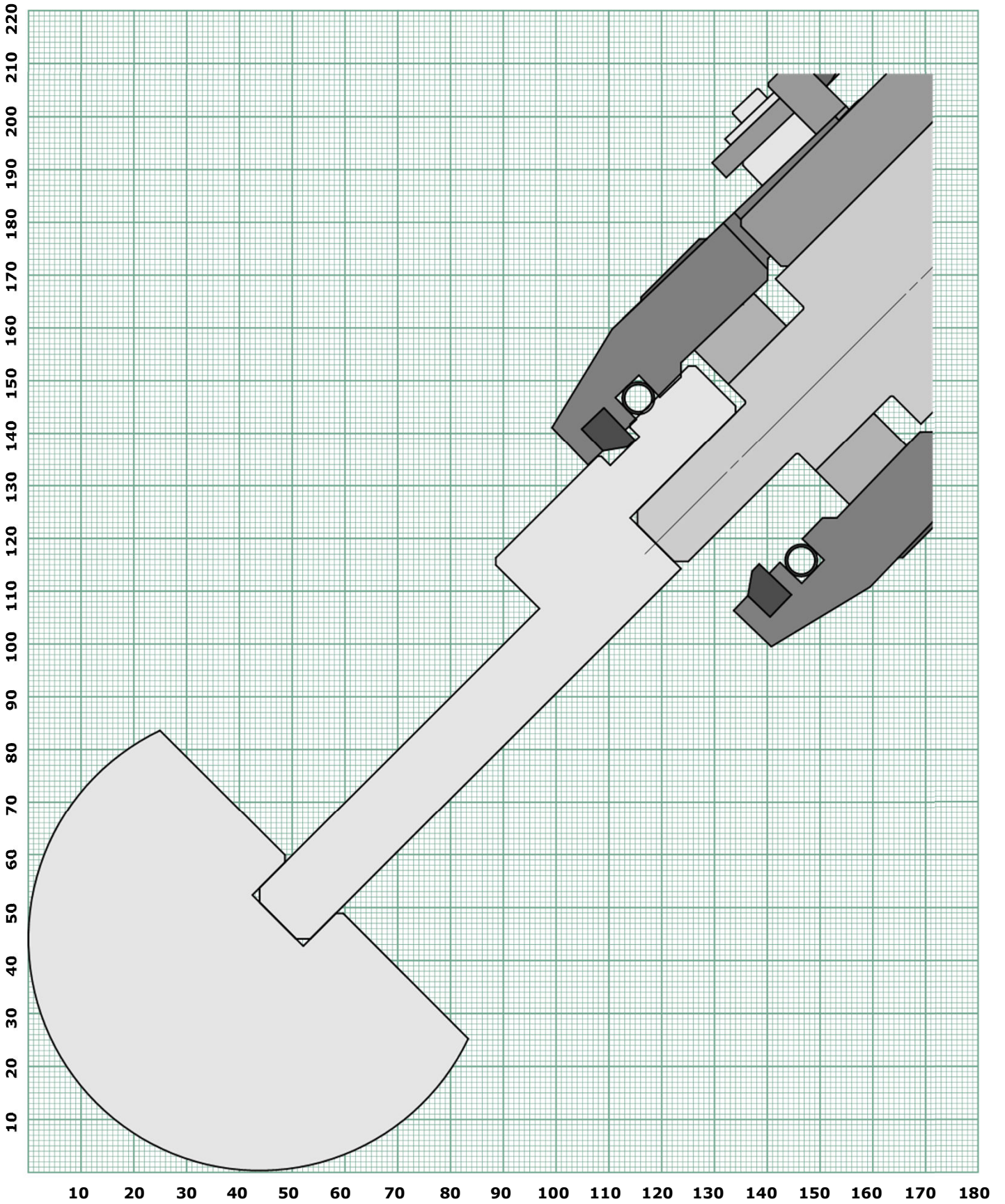

R50 Ruller with EH016 Holder

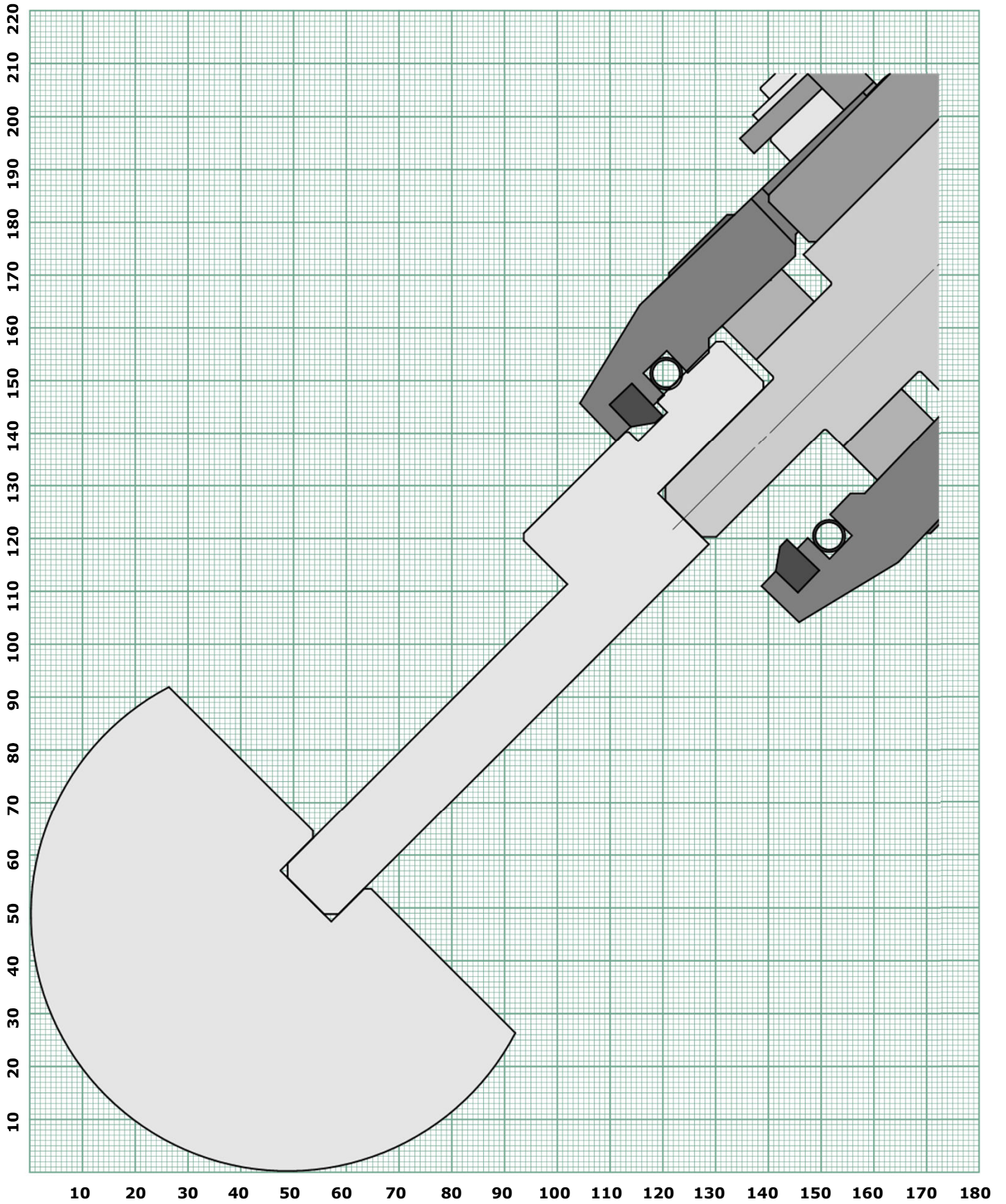

SEMISTANDARD PUNCH type 831 H200 30° R0,6

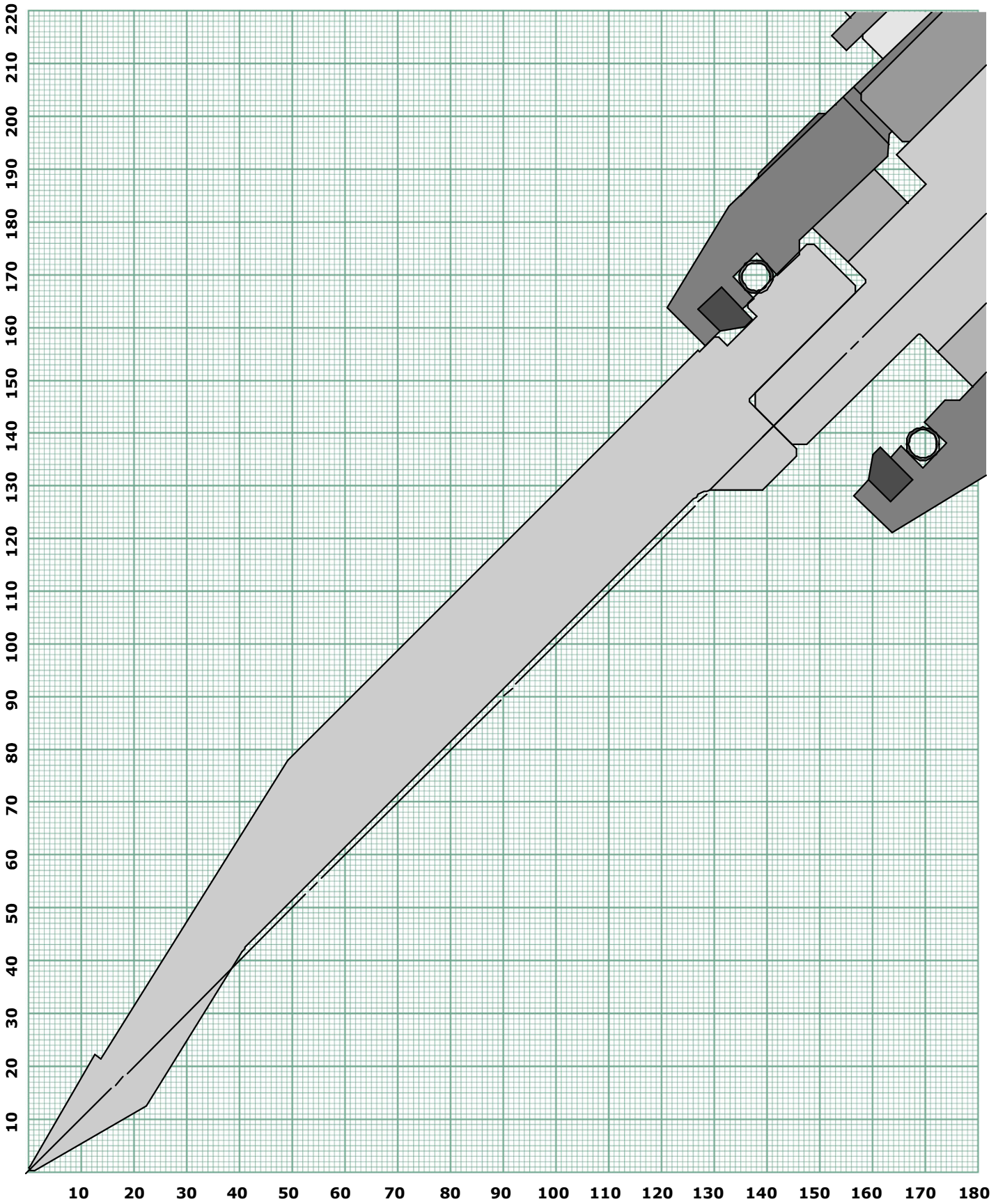

SEMISTANDARD PUNCH type 804 H220 86° R0,6

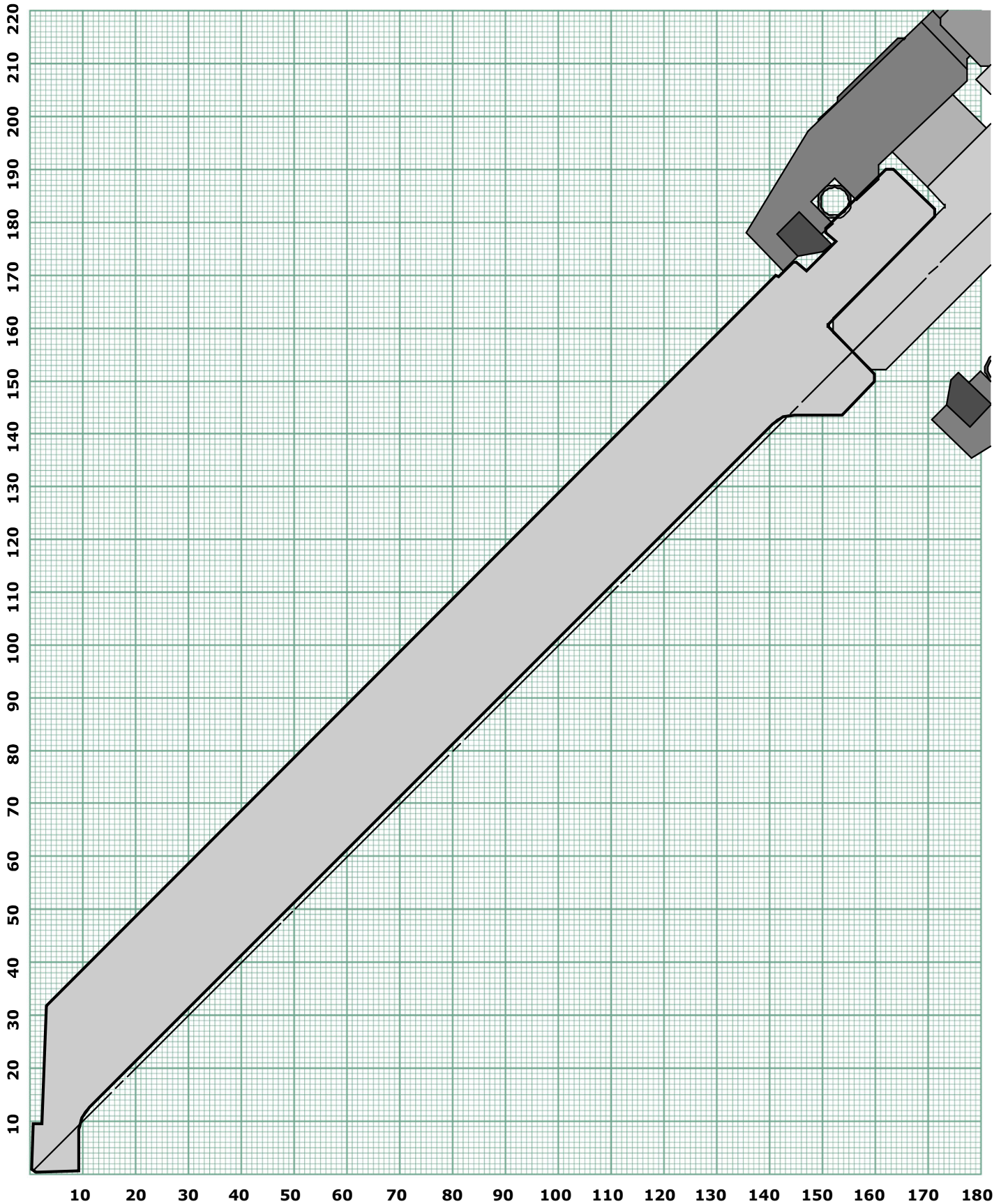

SEMISTANDARD PUNCH type 841 H200_W55 60° R0,6

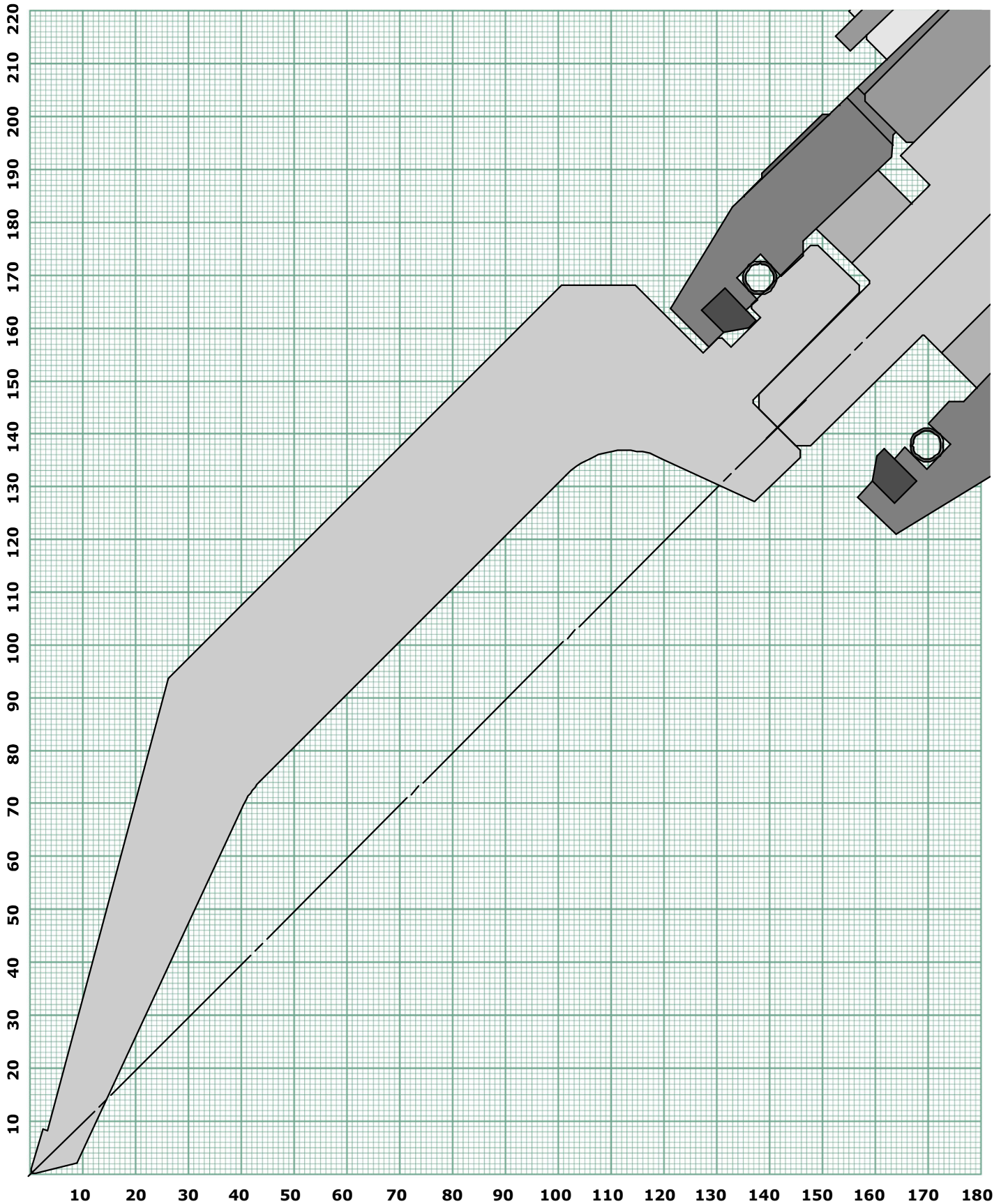

SEMISTANDARD PUNCH type 841 H200_W95 60° R0,6

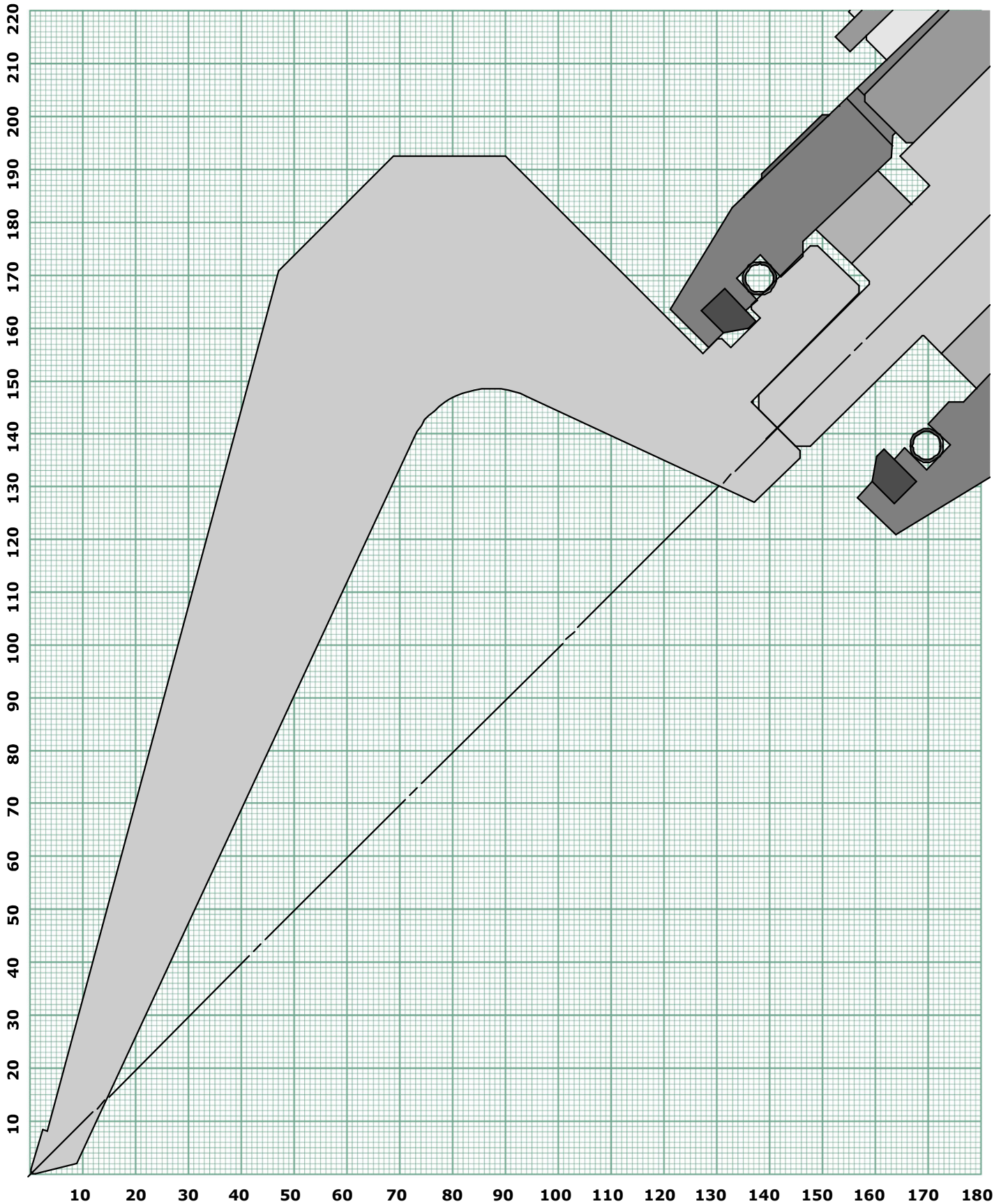

SEMISTANDARD PUNCH type 846 H200_W55 86° R0,6

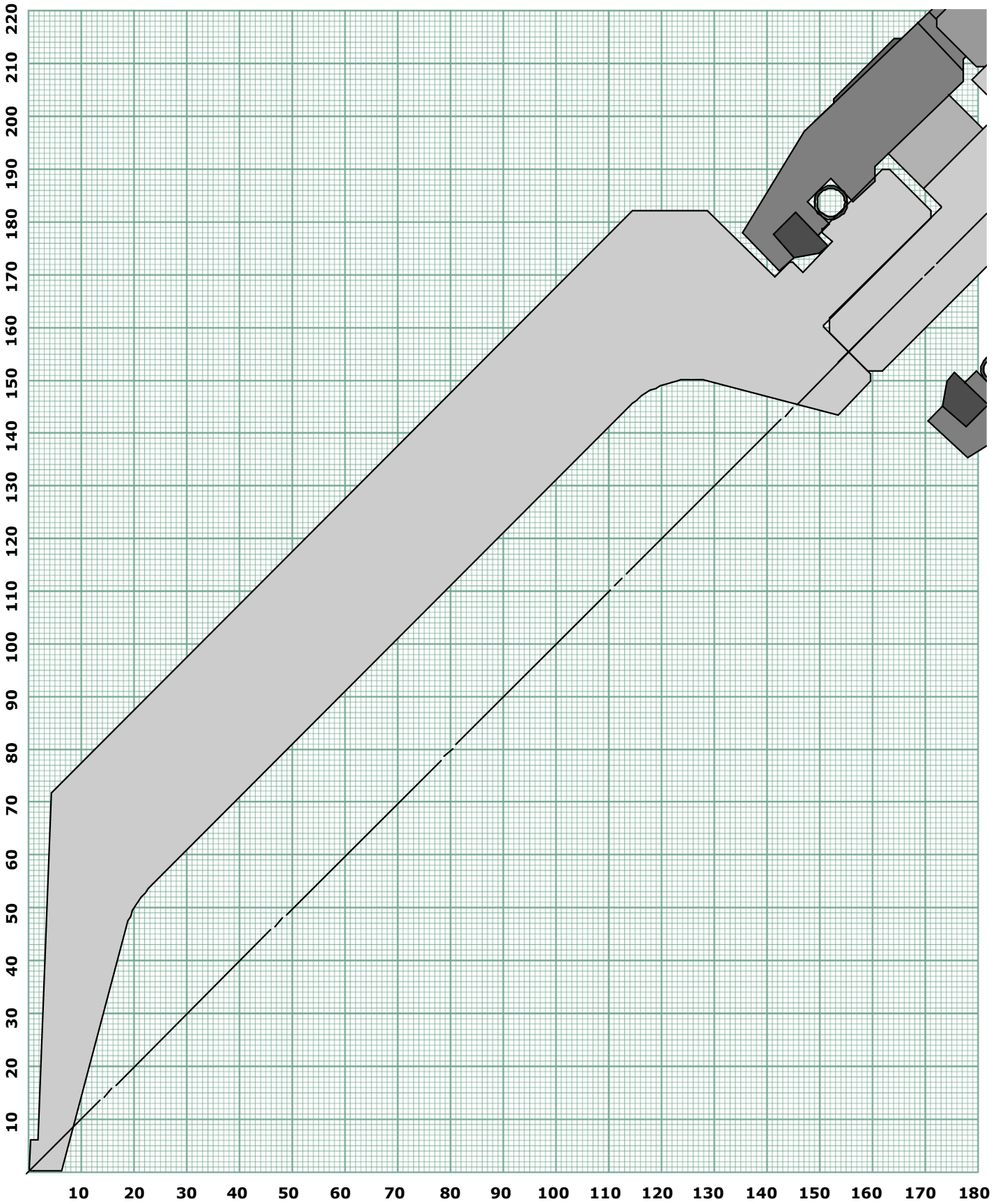

SEMISTANDARD PUNCH type 846 H220_W95 86° R0,6

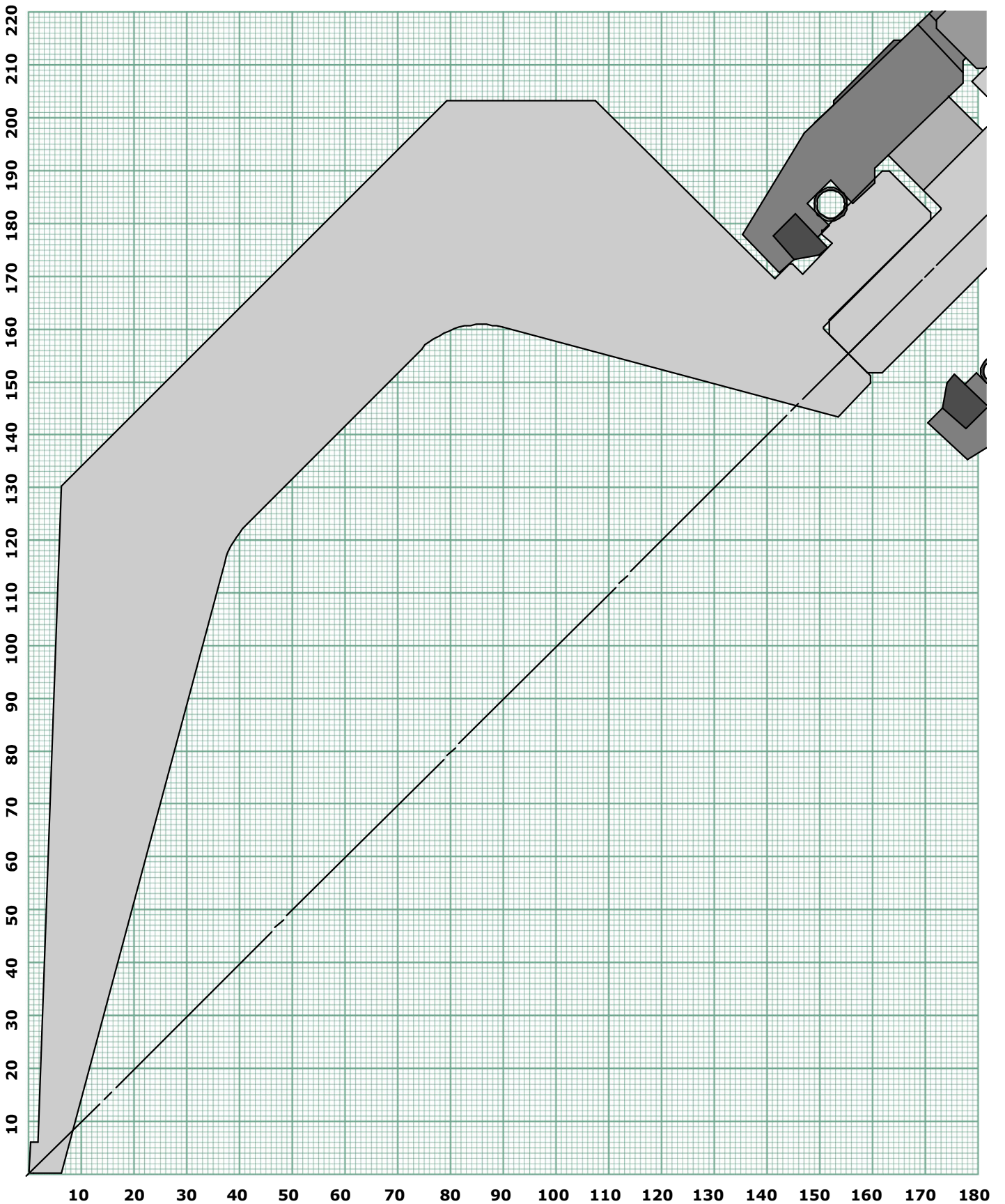

SEMISTANDARD PUNCH type 846 H200_W110 86° R0,6

