

NEW AFH STANDARD

PRESS BRAKE TOOLING



CLICK ON YOUR PAGE LINK

- AMADA Quality ----- 3
- NEW AFH - new tooling range ----- 4-6
- Length of tool sets ----- 7

PUNCHES

- Punches H120 86° ; 88° ; 90° ----- 8-10
- Punches H120 60° ----- 11
- Punches H120 26°; 30° ----- 12
- Large R and flattening punches----- 13
- Punches H90 ----- 14-17
- Punches H160 ----- 18-19
- Punches H70 ----- 20-22
- Radius punches ----- 23-25

DIES

- Insert dies 30° ----- 26-28
- Insert dies 45° ----- 29
- Insert dies 60° ----- 30-31
- Insert dies 84° 86° 88° 90° ----- 32-37
- Insert hemming and offset tools ----- 38-39
- 2V Reversible dies ----- 40-42
- Large V dies ----- 43-45
- Hemming dies ----- 46-48

MARK FREE BENDING

- Scratch free tools and accessories ----- 49-52

HOLDERS, OTHER TOOLINGS AND ACCESSORIES

- Die holders ----- 53-57
- Punch holders ----- 58-60
- Other tools and accessories ----- 61-65
- Semistandard tools ----- 66
- Special tools ----- 67-71

Tables and graphs ----- 71-103



Punch quality:
throughhardened from hot formed steel

- for long lasting high precision.
- surface hardness: **45-50 HRC**
- body strength: **1500 N/mm²**



Die quality : AMANIT®

- highest wear resistance on tool surface (**HRC 60-65**)
- low friction on the shoulder radii
- highest strength of the body - **1150 N/mm²**
- corrosion resistance

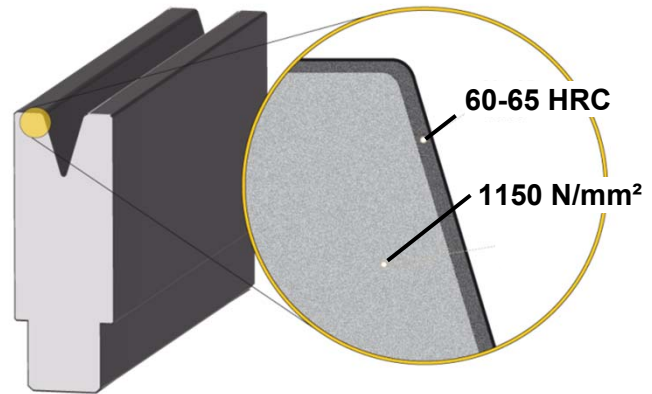

Tooling safety

With innovative heat treatment strategies and special testing techniques we are giving best durability to the steel, not only against failure caused by dead loads but also against fatigue caused by an infinite number of repeated loads.

Non corrosive coating on punch body

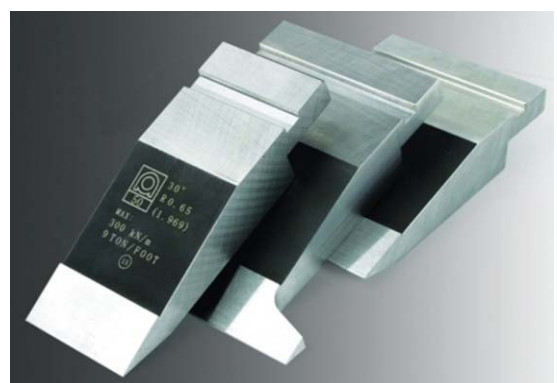

Single source

for machine, tooling and software

Complete laser marking

All Amada press brake toolings are completely marked by laser. Essential information like tooling type, angle, tonnage, length and radius are marked even on the sectional parts. Special markings are available at additional cost

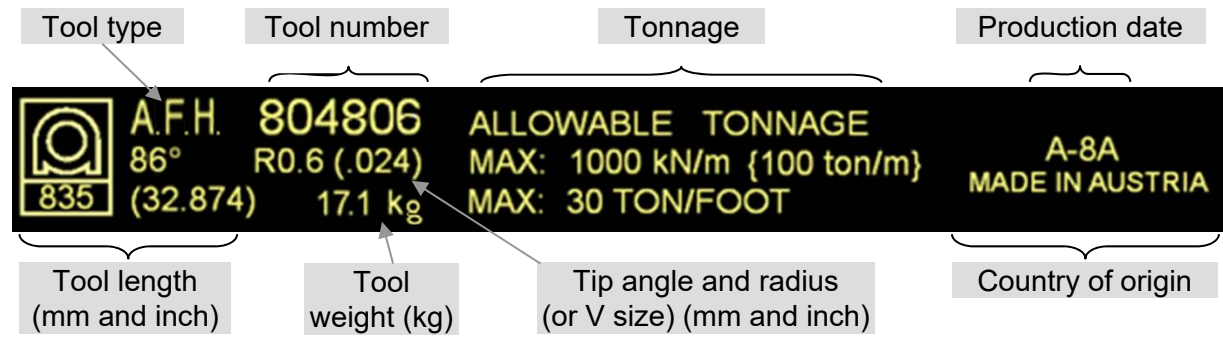

Standard tooling lengths:

L = 835mm ; S = 415mm ; Sectionalized = 800mm

Sectionalization :



Punch: 100ear; 10; 2 X 15; 20; 40; 50; 150; 300; 100ear = 800mm
 Die : 100; 10; 2 X 15; 20; 40; 50; 150; 400 = 800mm

Special lengths are available at additional cost.

We are aware of the necessity to manufacture high professional tools. All our activities are targeting precision, performance and safety. Being the first company offering standard tools for unlimited staged bending or offering standard tools for more process reliability while boosting tool life with AMANIT™, we repeatedly demonstrated that all our activities are developed in close coordination with our customers, meeting the demands of the “best in class”.

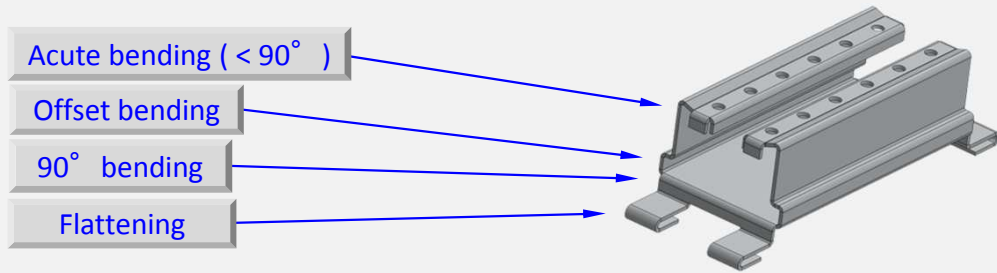

For example, the manufacturing of above electronic chassis requires 90-degree bends, acute bends, hems and offset bends. Using traditional bending, the operator would set up his press brake several times, handling the same part again and again. Press brake tools would play a significant role in this case. Because of their differing heights, they mostly allow only identical stages on same machine. As a result, several setup times have to be added to the processing cost.

Our New AFH tools are designed in order to enable the operator to setup multiple bends within one brake bed. While in the past the operator was more focused on tool alignments and how different tools could run at the same time, the New AFH now allows focusing on his sheet part, giving trouble-free, unlimited staging possibilities. Staged bending will make small runs cost-effective by simplifying complex bending sequences and handling each part only once.

Our punches are categorized into four levels, depending on their operating height. **H70mm, H90mm, H120mm and H160mm**. Our **staged dies** are offering stage bending in combination with acute bending, hemming and offset bending. NEW AFH is the successful unification of our powerful tooling systems like OneStroke or AFH with standard tools.

Example for tooling choice with H120 punches

<p>84°; 86°; 88°; 90° R0,6 - R3</p>	<p>60° R0,6 - R6</p>	<p>30° R0,6 - R4</p>	<p>R R7 - R50</p>	<p>Z Z3 - Z10</p>
<p>V4 - V40</p>	<p>V6 - V25</p>	<p>V6 - V25</p>	<p>...V40</p>	<p>tools usable as punches and as dies</p>



With stage bending, the operator can carry a complex part through multiple bends on different tool sets within one brake bed, and finish it after just one handling.

All tools for these options are available from stock.

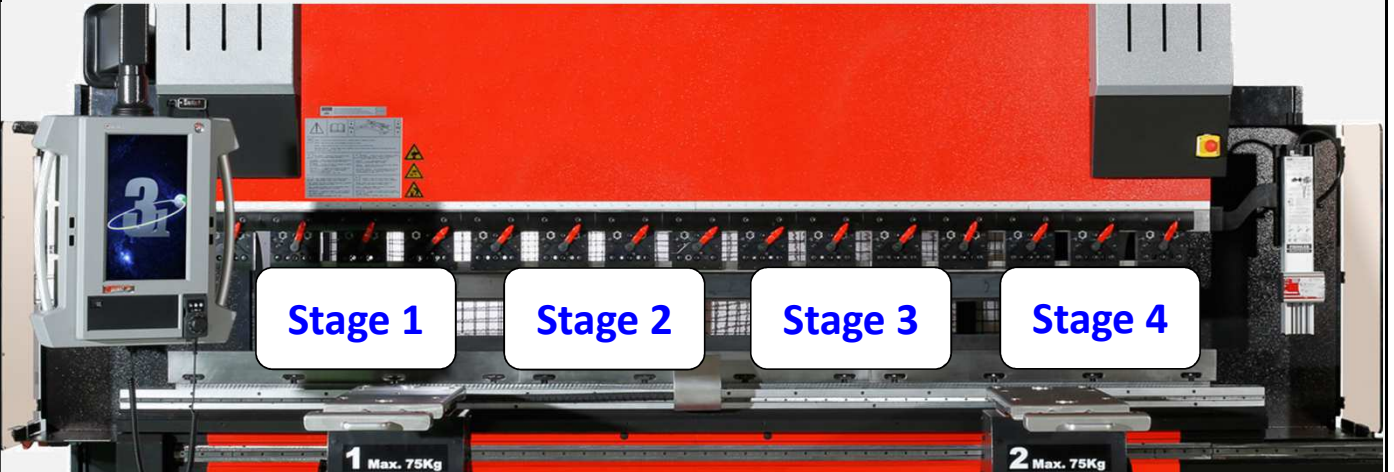

Stage engineering for sheet parts needing only 90° bends :

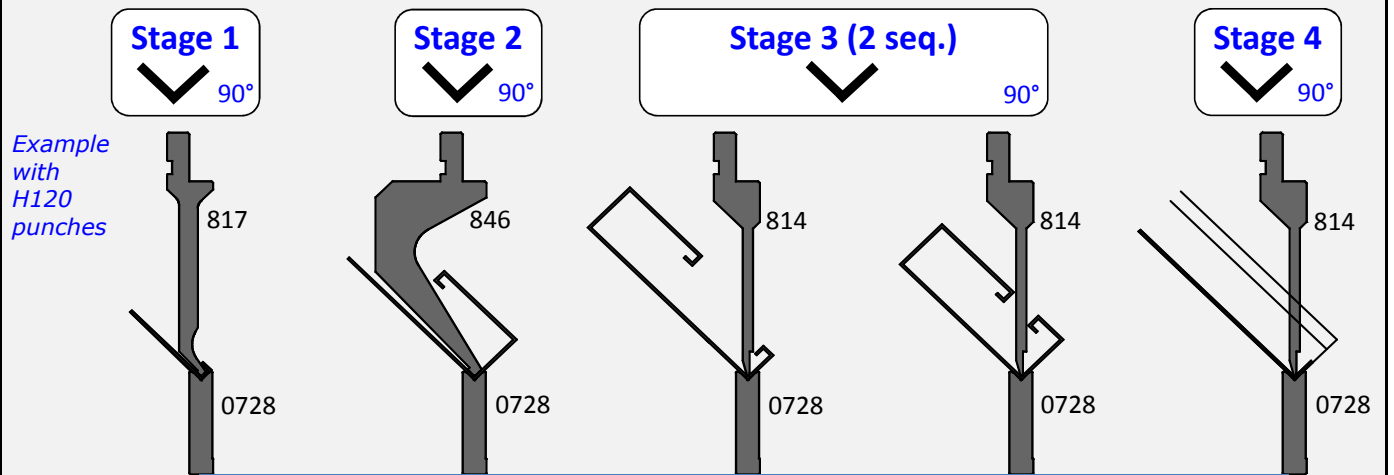

- Note:
- for perfect staging please use H120 punches (alternatively H90 or H160)
 - all H120 - R0,6 punches are manufactured on same height (AFH principle)
 - please use H60 dies from type 070... to 088...
 - all above tools are able to build unlimited stages for 90° bends

Stage engineering for parts needing multiple bends :

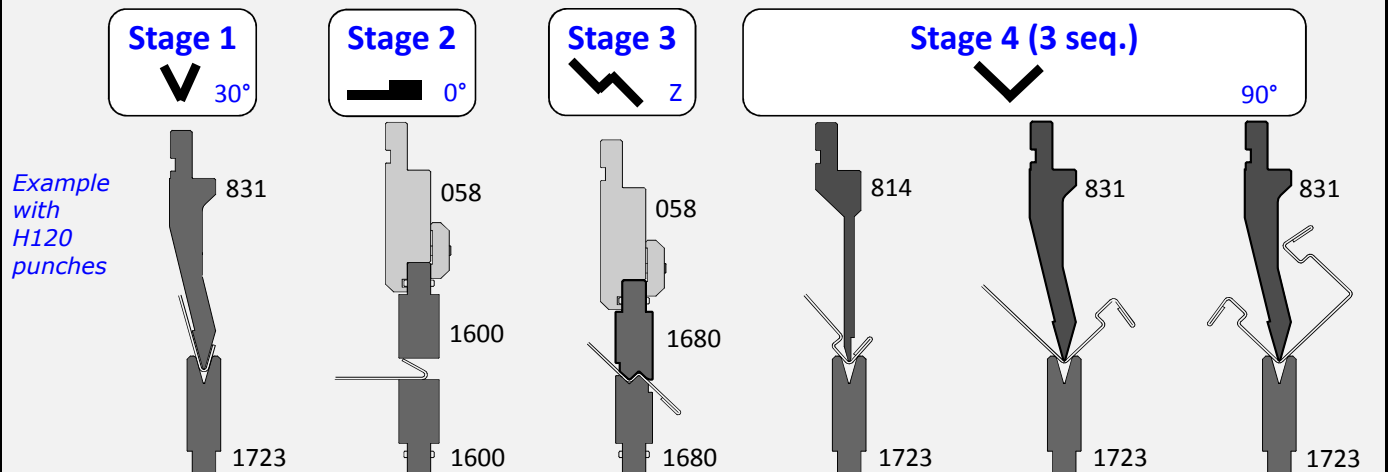

- Note:
- for perfect staging please use H120 punches (alternatively H90 or H160)
 - please use dies from type 170... to 182...
 - all staged dies paired with H120 (alternatively H90 or H160) punches have common shut height making brake setup fast and stage bending easy
 - Common shut height tools available for 90°, sharp angle, hemming and offset bending

■ Dies prepared for minimal offset values:

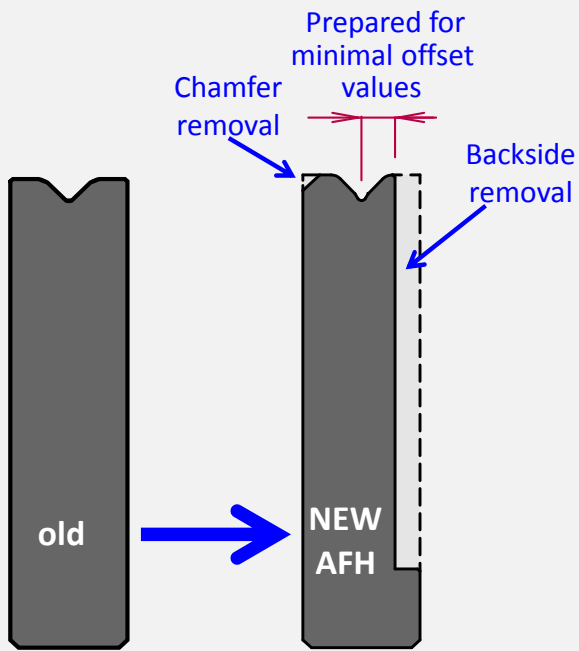

Examples:

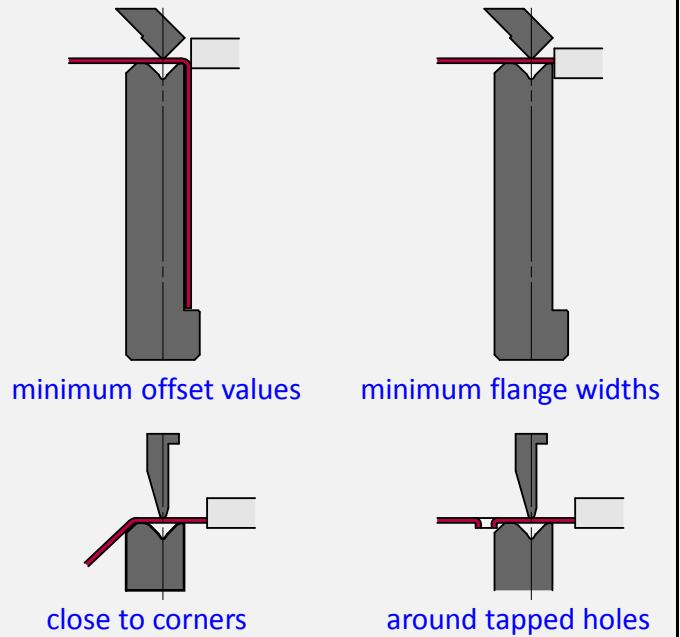

■ Use with angle measurement system :

To ensure the highest part accuracy from the very first bend, an angle measuring and correcting system like BIS, BIJ or BIL is necessary. All generated bend correction data from our angle measuring systems are calibrated with NEW AFH tools.

- Enlarges return bend area around the punch
- Eases software success of Dr.ABE BEND
- Prevents mistakes due to same punch height
- Quick change in combination with AGRIP clamps

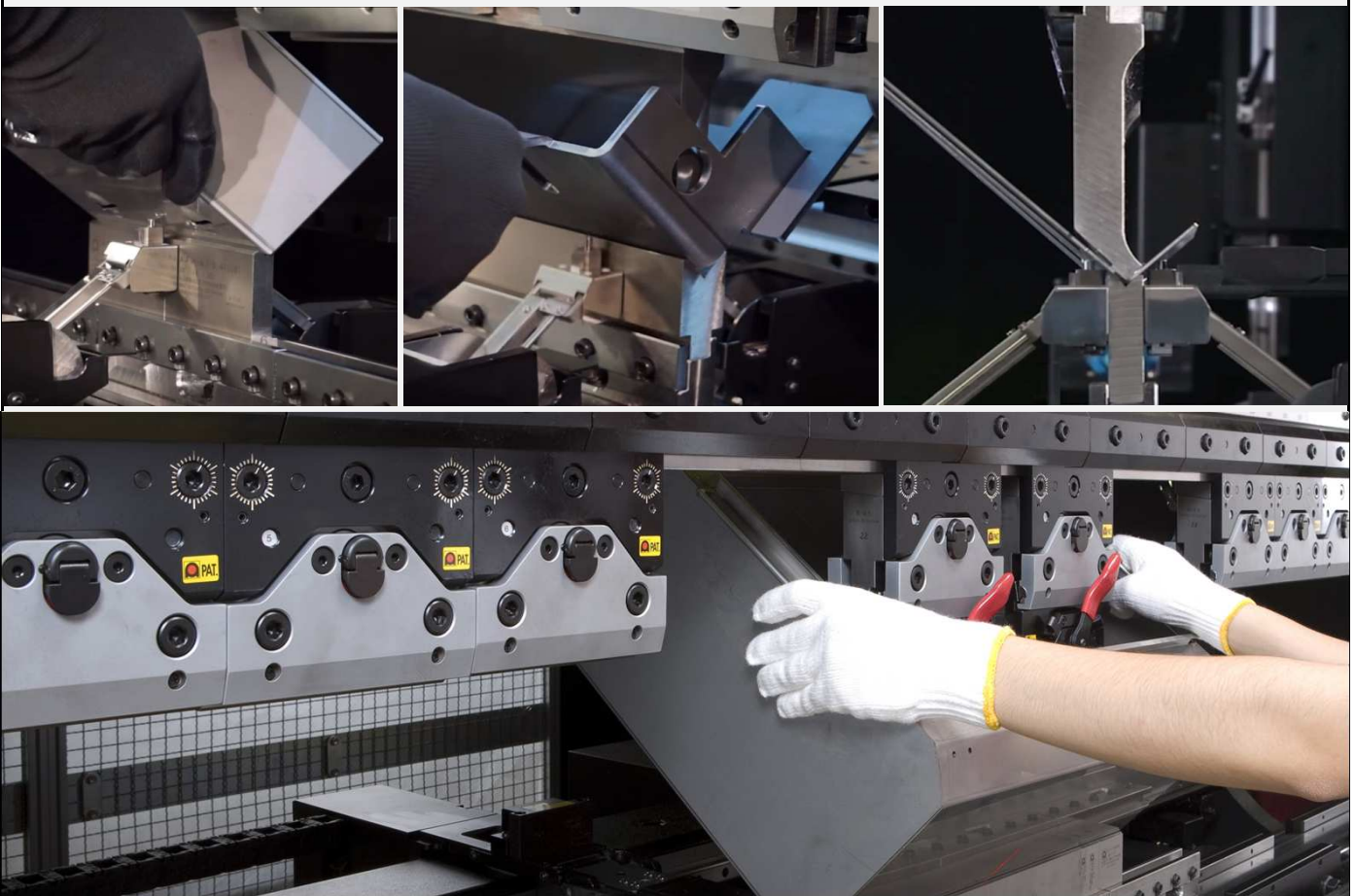

Combination of tool-sets per machine length

Machine length m				Tool-set length mm
	835 solid	415 solid	800 sect.	
1,2	1	1		1.250
		3		1.245
		1	1	1.215
	1		1	1.635
2	2	1		2.085
	2		1	2.470
	1	1	1	2.050
		3	1	2.045
	1	2	1	2.465
2,5	3			2.505
	2	2		2.500
	2		1	2.470
	2	1	1	2.885
	1	2	1	2.465
	1		2	2.435
	1	3	1	2.880
	1	1	2	2.850
3	3	1		2.920
	3		1	3.305
	2	3		2.915
	2	2	1	3.300
	2	1	1	2.885
	2		2	3.270
	1	5		2.910
	1	4	1	3.295
	1	2	2	3.265
		4	2	3.260
4	5			4.175
	4	2		4.170
	4	1	1	4.555
	4		1	4.140
	3	3	1	4.550
	3	2	1	4.135
	3	1	2	4.520
	3		2	4.105
	2	2	2	4.100

Worldwide sales organization, ensuring excellent availability all over the world, and guaranteeing outstanding service for the customers



AFH Standard Punch 804 (9 mm tip)

Punch 804 replaces old punches [S51](#); [S52](#); [A04](#); [A16](#)

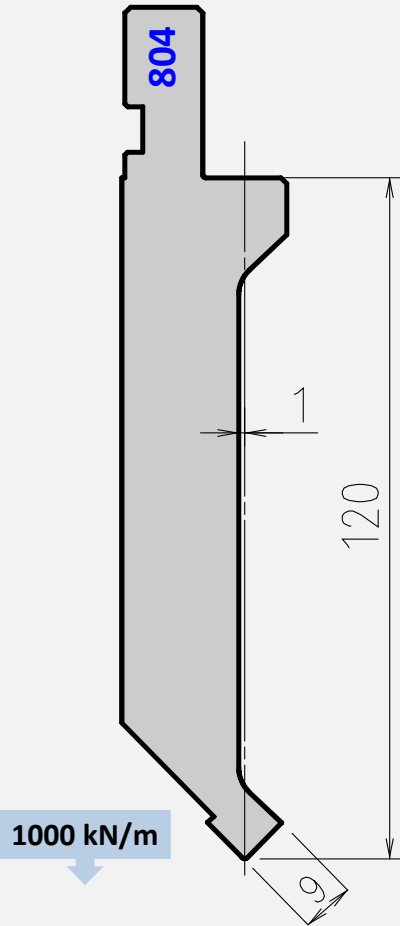

Tool angle	Tip radius	Length mm	Item No.	Weight Kg
86°	R0.6	835	ES 8048061	17,1
		415	ES 8048062	8,5
		800 Sect	ES 8048063	15,1
	R1.5	835	ES 8048151	17,1
		415	ES 8048152	8,5
		800 Sect	ES 8048153	15,1
	R3	835	ES 8048301	17,1
		415	ES 8048302	8,5
		800 Sect	ES 8048303	15,1
88°	R0.6	835	ES 8047061	17,1
		415	ES 8047062	8,5
		800 Sect	ES 8047063	15,1
90°	R0.6	835	ES 8049061	17,1
		415	ES 8049062	8,5
		800 Sect	ES 8049063	15,1

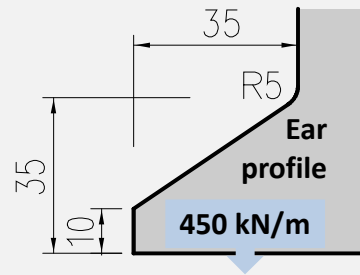

AFH Standard Punch 847 (9 mm tip)

Punch 847 replaces old punches [45](#); [47](#); [S55](#); [S56](#); [A47](#); [A48](#).

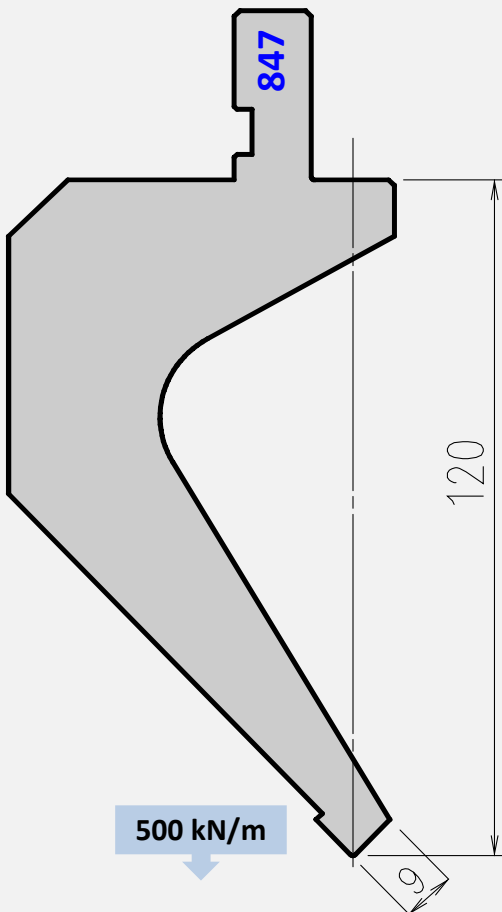

Tool angle	Tip radius	Length mm	Item No.	Weight Kg
86°	R0.6	835	ES 8478061	25,2
		415	ES 8478062	12,5
		800 Sect	ES 8478063	22,2
	R1.5	835	ES 8478151	25,2
		415	ES 8478152	12,5
		800 Sect	ES 8478153	22,2
	R3	835	ES 8478301	25,2
		415	ES 8478302	12,5
		800 Sect	ES 8478303	22,2
88°	R0.6	835	ES 8477061	25,2
		415	ES 8477062	12,5
		800 Sect	ES 8477063	22,2
90°	R0.6	835	ES 8479061	25,2
		415	ES 8479062	12,5
		800 Sect	ES 8479063	22,2

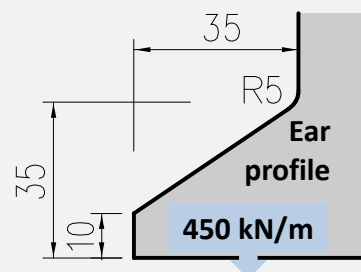

AFH Sash Punch 820 (8 mm tip)

Punch 820 replaces old punches 202; A20; A21

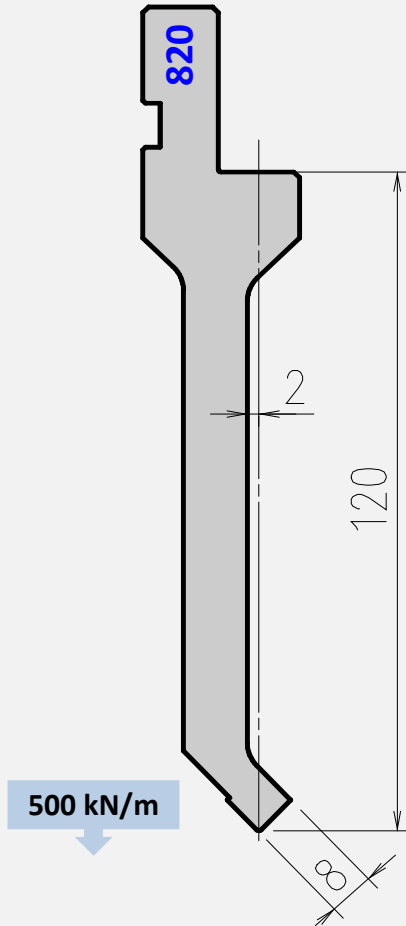

Tool angle	Tip radius	Length mm	Item No.	Weight Kg
86°	R0.6	835	ES 8208061	11,7
		415	ES 8208062	5,8
		800 Sect	ES 8208063	10,5
	R1.5	835	ES 8208151	11,7
		415	ES 8208152	5,8
		800 Sect	ES 8208153	10,5
88°	R0.6	835	ES 8207061	11,7
		415	ES 8207062	5,8
		800 Sect	ES 8207063	10,5

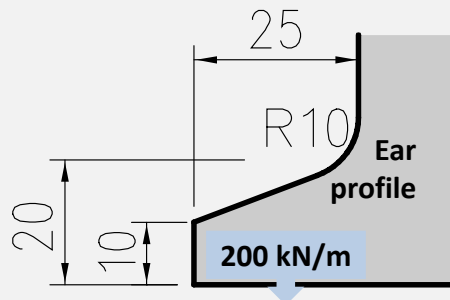

AFH Sash Punch 817 (4 mm tip)

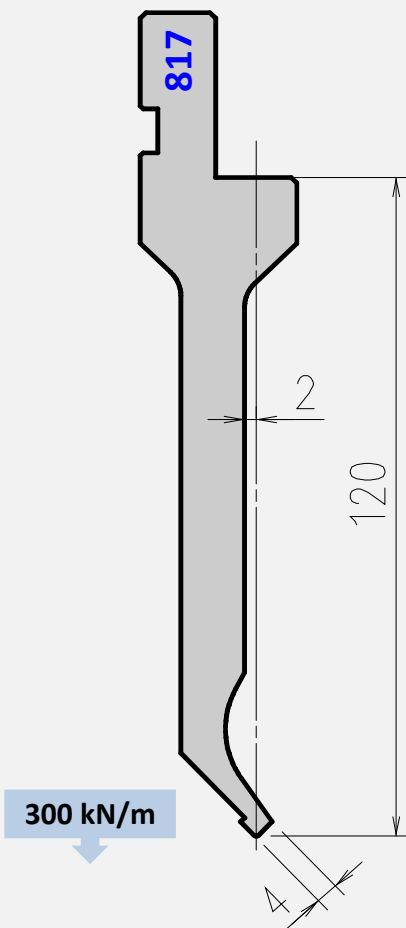

Tool angle	Tip radius	Length mm	Item No.	Weight Kg
86°	R0.6	835	ES 8178061	11,1
		415	ES 8178062	5,5
		800 Sect	ES 8178063	10,4
88°	R0.6	835	ES 8177061	11,1
		415	ES 8177062	5,5
		800 Sect	ES 8177063	10,4

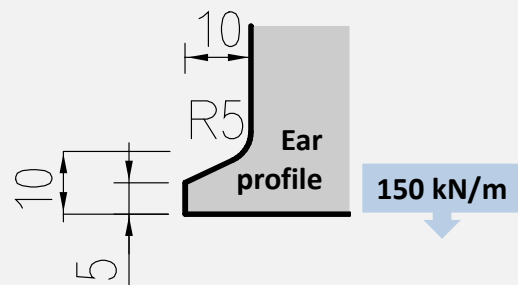

AFH Thin Gooseneck Punch 846 (6 mm tip)

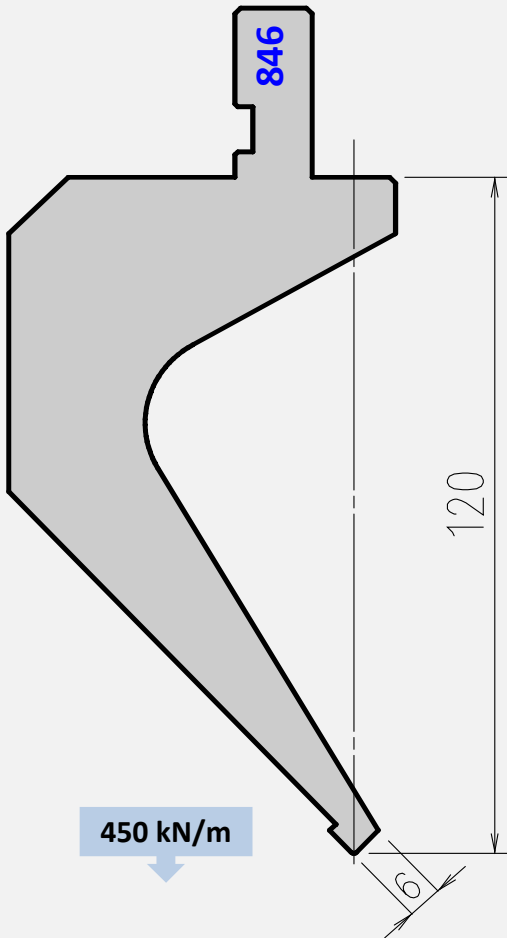

Tool angle	Tip radius	Length mm	Item No.	Weight Kg
86°	R0.6	835	ES 8468061	23,3
		415	ES 8468062	11,6
		800 Sect	ES 8468063	20,5
88°	R0.6	835	ES 8467061	23,3
		415	ES 8467062	11,6
		800 Sect	ES 8467063	20,5

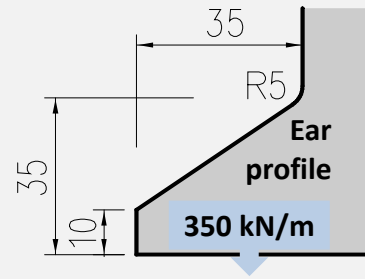

AFH Acute Sash Punch 840

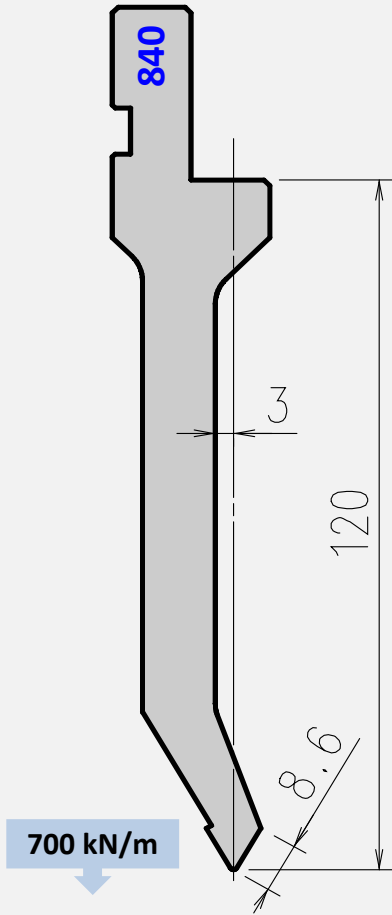

Tool angle	Tip radius	Length mm	Item No.	Weight Kg
60°	R0.6	835	ES 8406061	12,4
		415	ES 8406062	6,2
		800 Sect	ES 8406063	11,0
	R1.5	835	ES 8406151	12,4
		415	ES 8406152	6,2
		800 Sect	ES 8406153	11,0

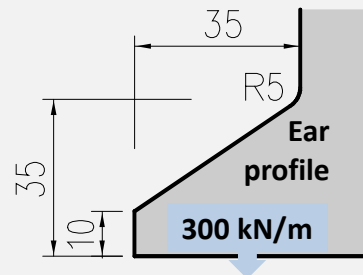

AFH Gooseneck Punch 841

Punch 841 replaces old punches 454

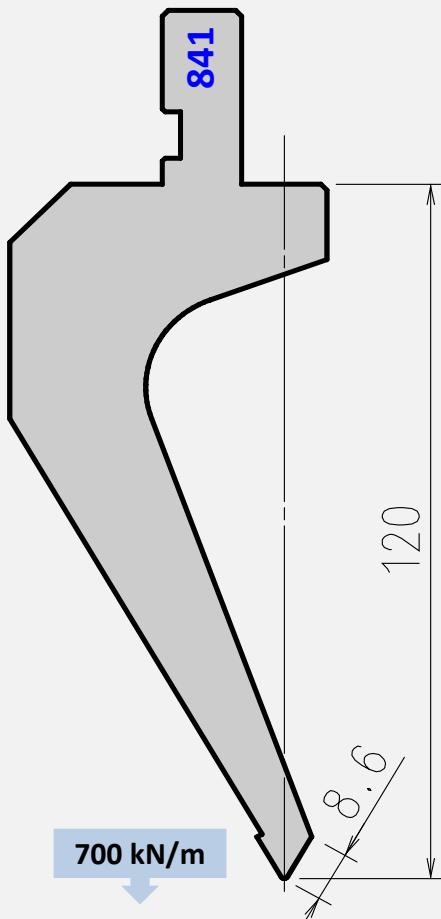

Tool angle	Tip radius	Length mm	Item No.	Weight Kg
60°	R0.6	835	ES 8416061	19,2
		415	ES 8416062	9,5
		800 Sect	ES 8416063	16,9
	R1.5	835	ES 8416151	19,2
		415	ES 8416152	9,5
		800 Sect	ES 8416153	16,9

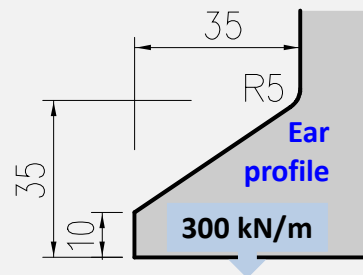

AFH Acute Angle Punch 814

Punch 814 replaces old punches [109](#); [S57](#); [S58](#); [A18](#); [A19](#); [A13](#).

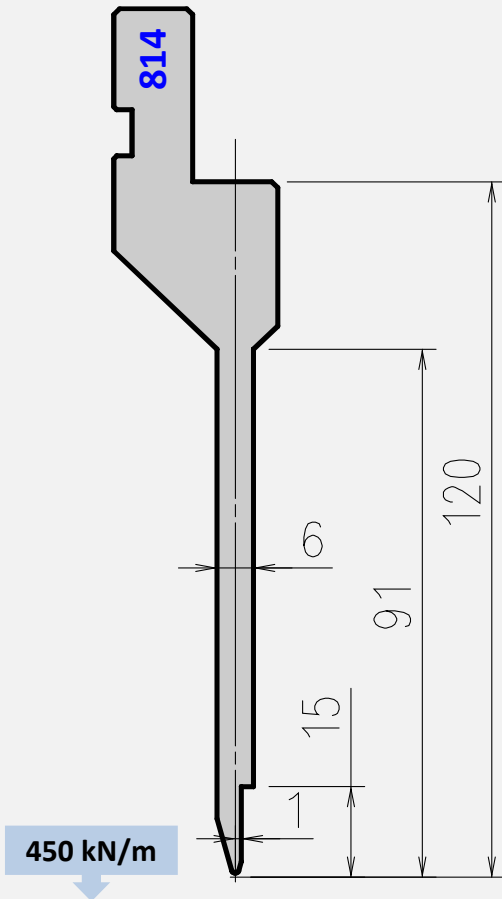

Tool angle	Tip radius	Length mm	Item No.	Weight Kg
30°	R0.6	835	ES 8143061	9,8
		415	ES 8143062	4,9
		800 Sect	ES 8143063	8,8

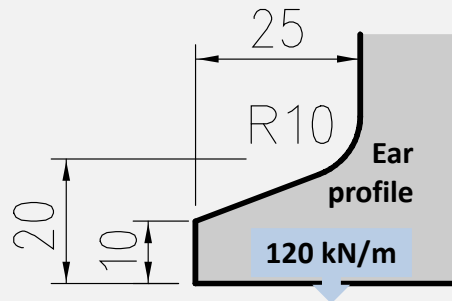

AFH Hemming Punch 831

Punch 831 replaces old punches [210](#), [Z330](#) and [S35](#).

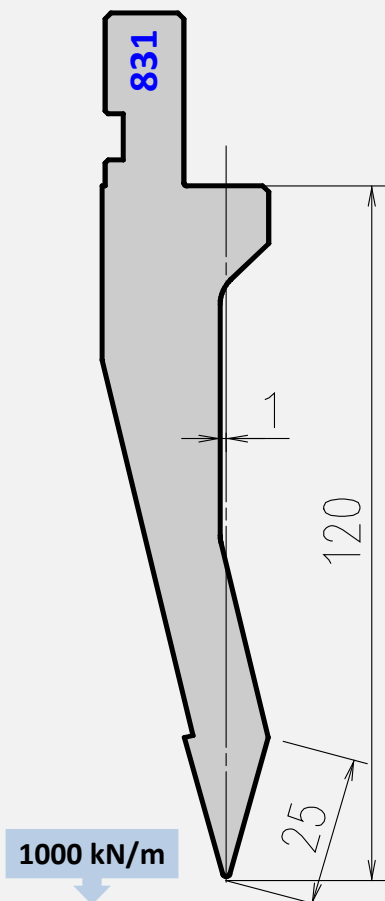

Tool angle	Tip radius	Length mm	Item No.	Weight Kg
26°	R0.6	835	ES 8312061	13,9
		415	ES 8312062	6,9
		800 Sect	ES 8312063	12,7
30°	R0.6	835	ES 8313061	14,1
		415	ES 8313062	7,0
		800 Sect	ES 8313063	12,9
	R1.5	835	ES 8313151	14,1
		415	ES 8313152	7,0
		800 Sect	ES 8313153	12,9
	R3	835	ES 8313301	13,9
		415	ES 8313302	6,9
		800 Sect	ES 8313303	12,7
R4	835	ES 8313401	13,9	
	415	ES 8313402	6,9	
	800 Sect	ES 8313403	12,7	

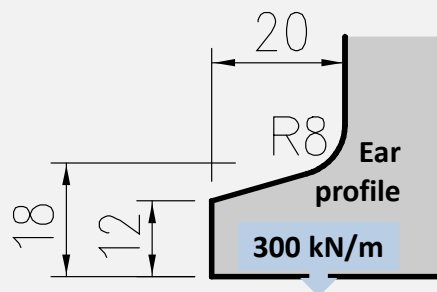

AFH Straight Punch 803

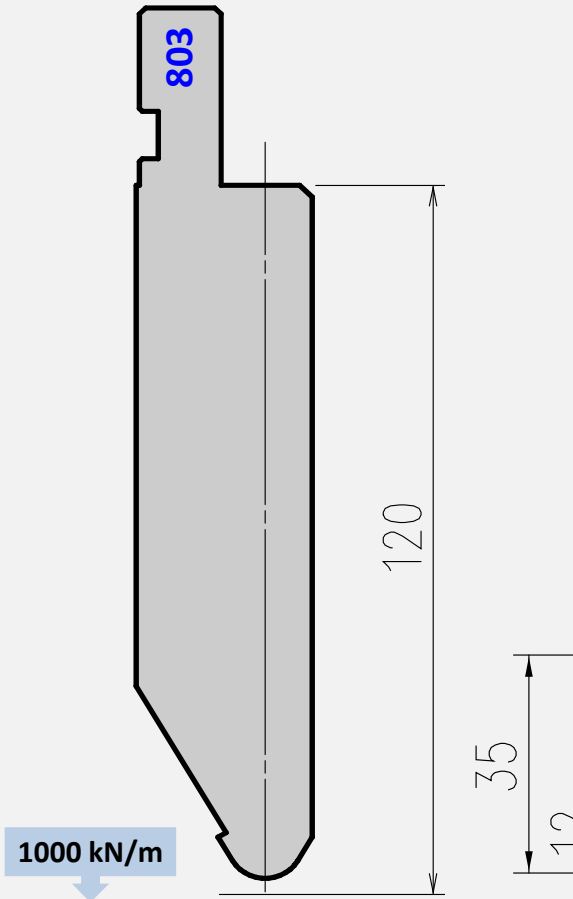

Tool angle	Tip radius	Length mm	Item No.	Weight Kg
60°	R5.0	835	ES 8036501	21,8
		415	ES 8036502	10,8
		800 Sect	ES 8036503	19,5
	R6.0	835	ES 8036601	21,8
		415	ES 8036602	10,8
		800 Sect	ES 8036603	19,5

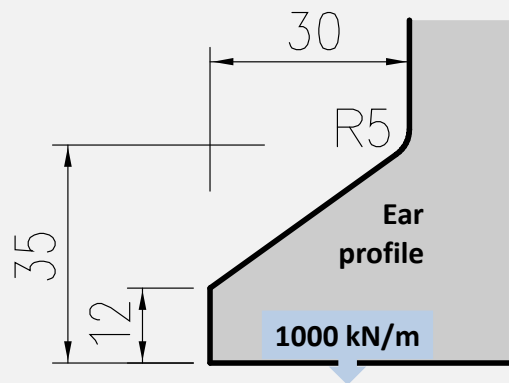

AFH Flattening Punch 822

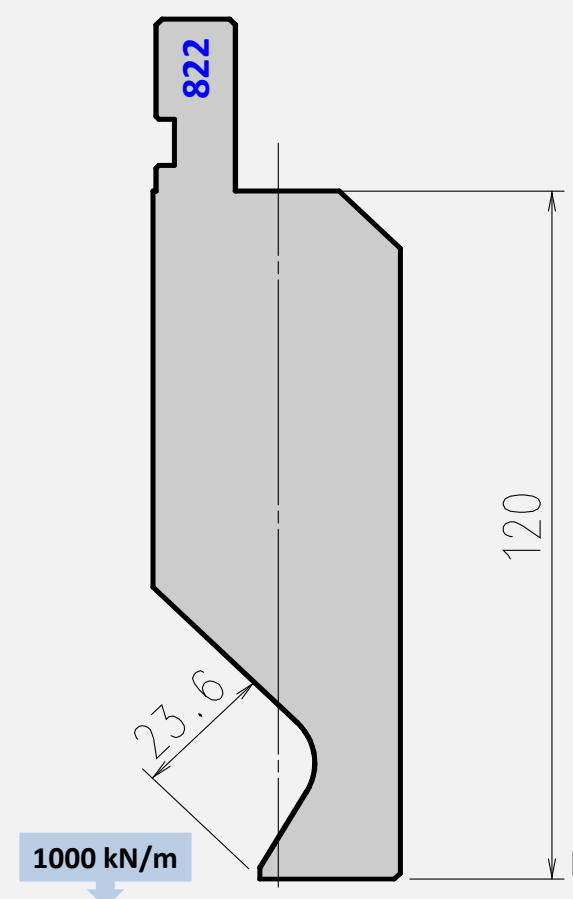

	Length mm	Item No.	Weight Kg
Flattening	835	ES 8220001	27,8
	415	ES 8220002	13,8
	800 Sect	ES 8220003	26,6

Example for staged flattening:

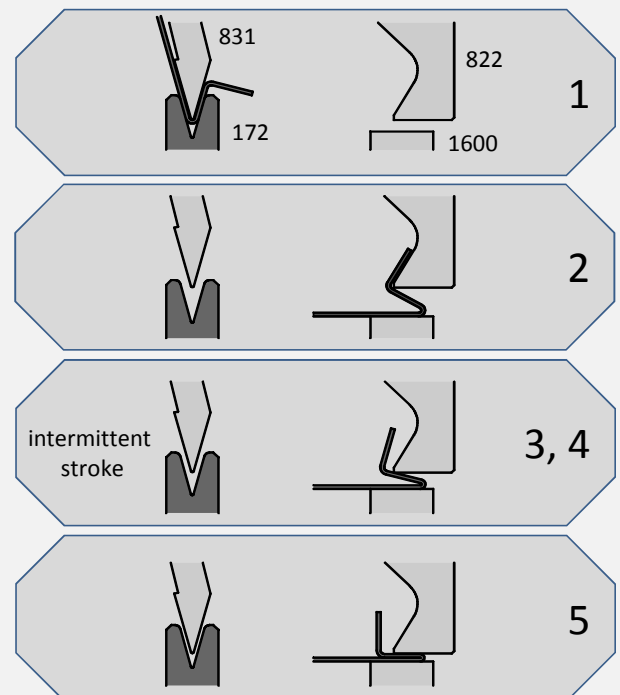

AFH Standard Punch 704 (9 mm tip)

Punch 704 replaces old punches S01; S02

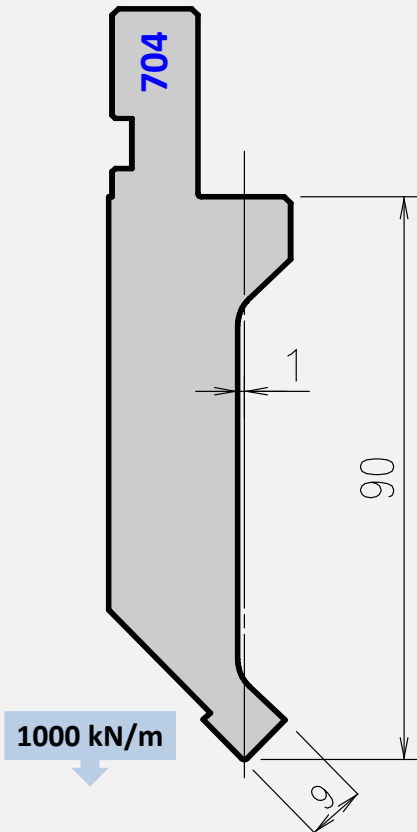

Tool angle	Tip radius	Length mm	Item No.	Weight Kg
86°	R0.6	835	ES 7048061	13,3
		415	ES 7048062	6,6
		800 Sect	ES 7048063	11,8
	R1.5	835	ES 7048151	13,3
		415	ES 7048152	6,6
		800 Sect	ES 7048153	11,8
	R3	835	ES 7048301	13,3
		415	ES 7048302	6,6
		800 Sect	ES 7048303	11,8
88°	R0.6	835	ES 7047061	13,3
		415	ES 7047062	6,6
		800 Sect	ES 7047063	11,8
90°	R0.6	835	ES 7049061	13,3
		415	ES 7049062	6,6
		800 Sect	ES 7049063	11,8

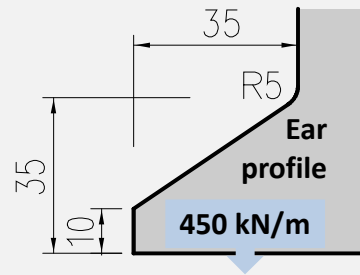

AFH Standard Punch 747 (9 mm tip)

Punch 747 replaces old punch 452

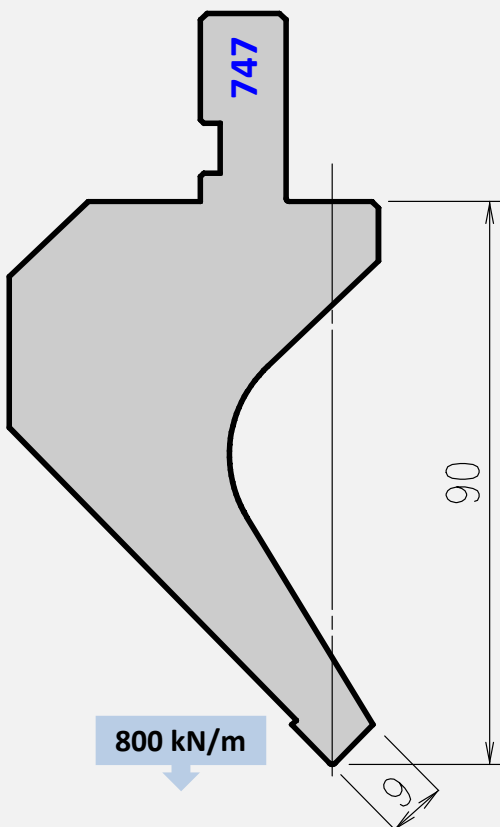

Tool angle	Tip radius	Length mm	Item No.	Weight Kg
86°	R0.6	835	ES 7478061	19,4
		415	ES 7478062	9,6
		800 Sect	ES 7478063	17,1
	R1.5	835	ES 7478151	19,4
		415	ES 7478152	9,6
		800 Sect	ES 7478153	17,1
	R3	835	ES 7478301	19,4
		415	ES 7478302	9,6
		800 Sect	ES 7478303	17,1
88°	R0.6	835	ES 7477061	19,4
		415	ES 7477062	9,6
		800 Sect	ES 7477063	17,1
90°	R0.6	835	ES 7479061	19,4
		415	ES 7479062	9,6
		800 Sect	ES 7479063	17,1

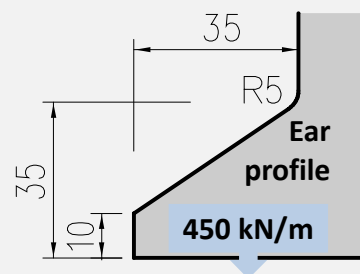

AFH Sash Punch 720 (8 mm tip)

Punch 720 replaces old punches S03; S04

Tool angle	Tip radius	Length mm	Item No.	Weight Kg
86°	R0.6	835	ES 7208061	9,1
		415	ES 7208062	4,5
		800 Sect	ES 7208063	8,2
	R1.5	835	ES 7208151	9,1
		415	ES 7208152	4,5
		800 Sect	ES 7208153	8,2
88°	R0.6	835	ES 7207061	9,1
		415	ES 7207062	4,5
		800 Sect	ES 7207063	8,2

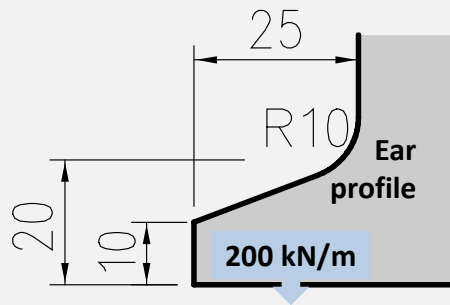
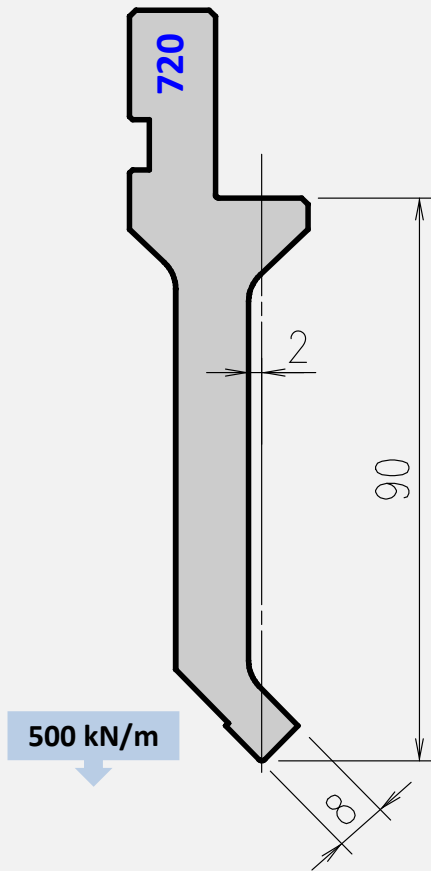

AFH Thin Gooseneck Punch 746 (6 mm tip)

Punch 746 replaces old punches 453; S05; S06

Tool angle	Tip radius	Length mm	Item No.	Weight Kg
86°	R0.6	835	ES 7468061	18,3
		415	ES 7468062	9,1
		800 Sect	ES 7468063	16,1
88°	R0.6	835	ES 7467061	18,3
		415	ES 7467062	9,1
		800 Sect	ES 7467063	16,1

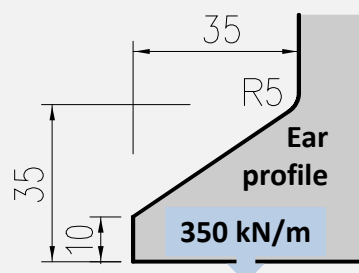
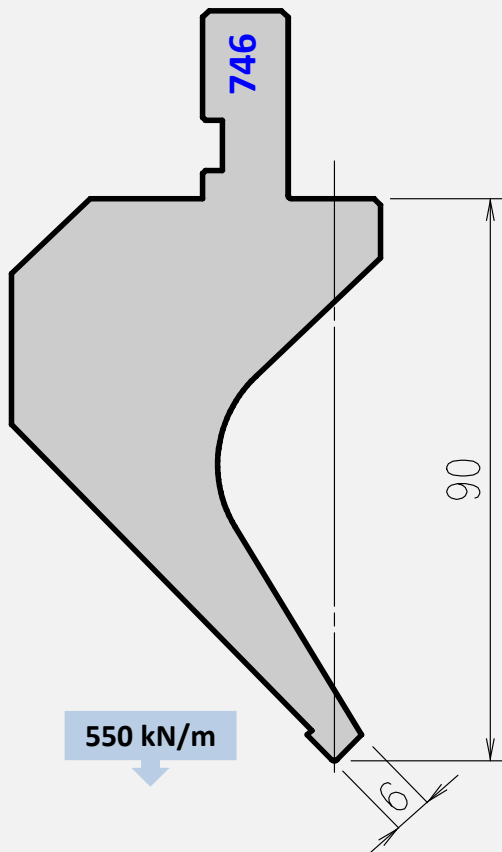

AFH Sash Punch 717 (4 mm tip)

Punch 717 replaces old punches Z2883; 670

Tool angle	Tip radius	Length mm	Item No.	Weight Kg
86°	R0.6	835	ES 7178061	11,8
		415	ES 7178062	5,8
		800 Sect	ES 7178063	11,0
88°	R0.6	835	ES 7177061	11,8
		415	ES 7177062	5,8
		800 Sect	ES 7177063	11,0

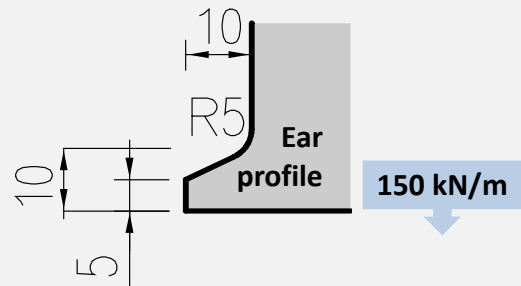
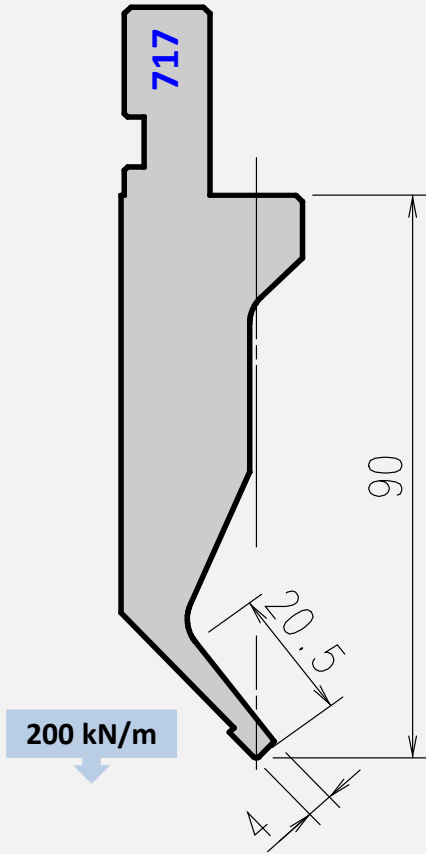

AFH Acute Angle Punch 713

Punch 713 replaces old punches S07; S08; S31

Tool angle	Tip radius	Length mm	Item No.	Weight Kg
30°	R0.6	835	ES 7133061	8,7
		415	ES 7133062	4,3
		800 Sect	ES 7133063	7,9

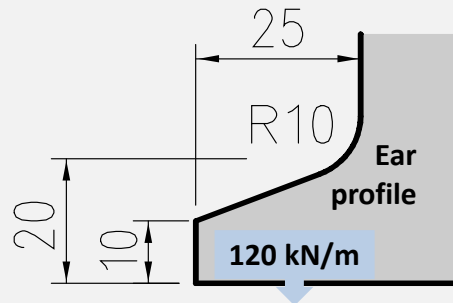
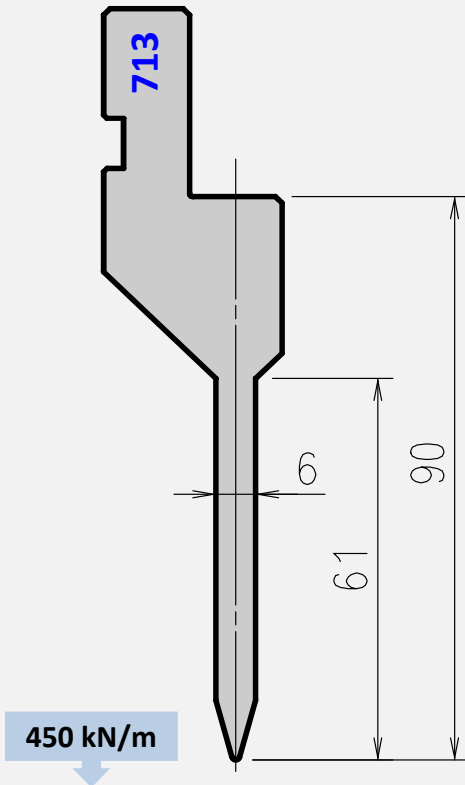

AFH Hemming Punch 731

Punch 731 replaces old punches 211; S30

Tool angle	Tip radius	Length mm	Item No.	Weight Kg
30°	R0.6	835	ES 7313061	10,1
		415	ES 7313062	5,0
		800 Sect	ES 7313063	9,2
	R1.5	835	ES 7313151	10,1
		415	ES 7313152	5,0
		800 Sect	ES 7313153	9,2
	R3	835	ES 7313301	10,1
		415	ES 7313302	5,0
		800 Sect	ES 7313303	9,2

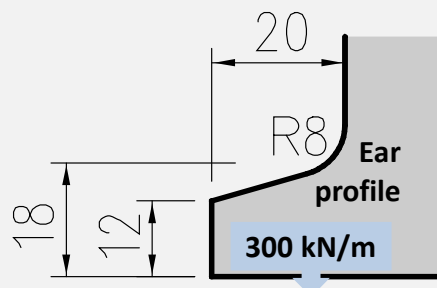
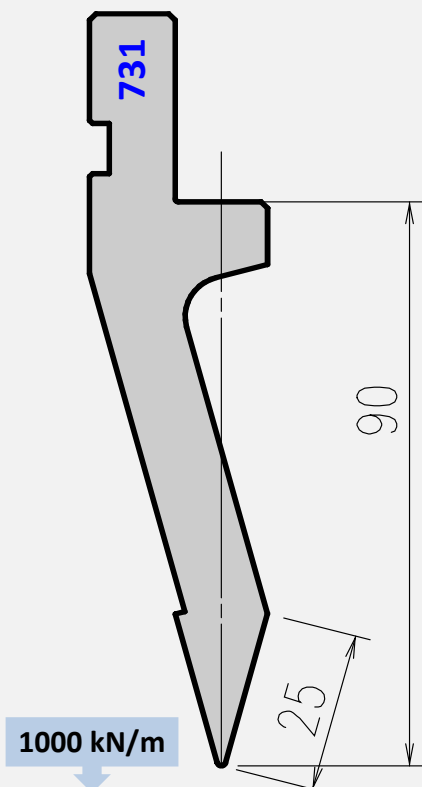

AFH Std. Punch 904

AFH Acute Angle Punch 914

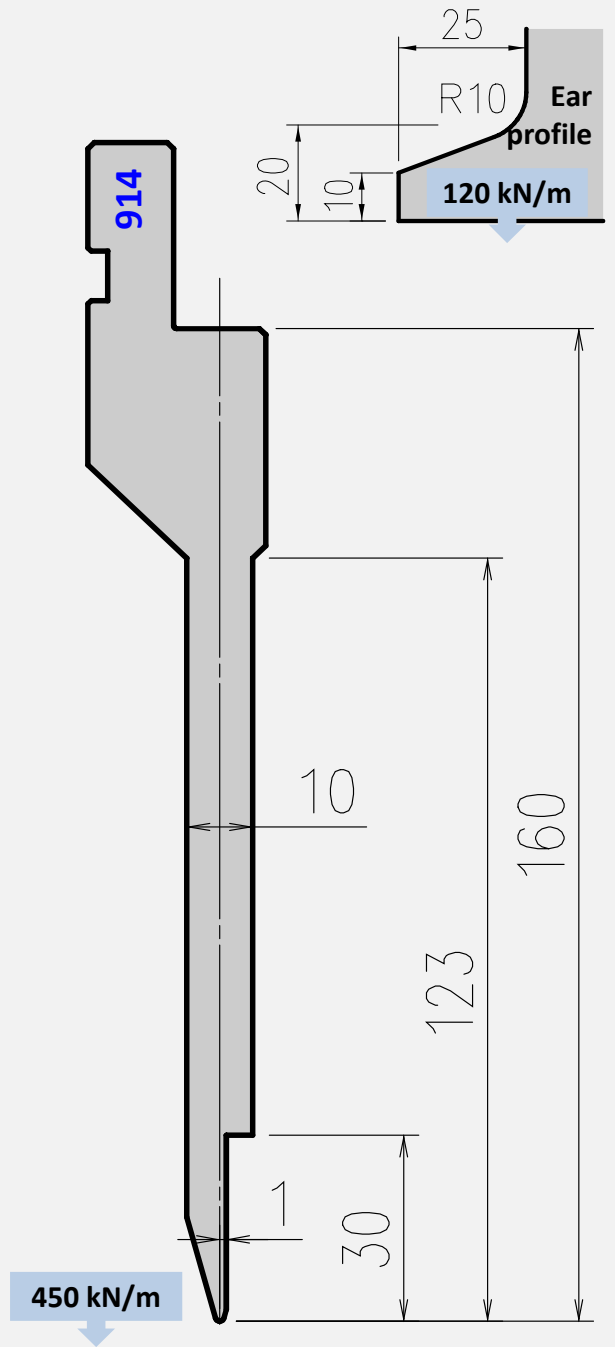
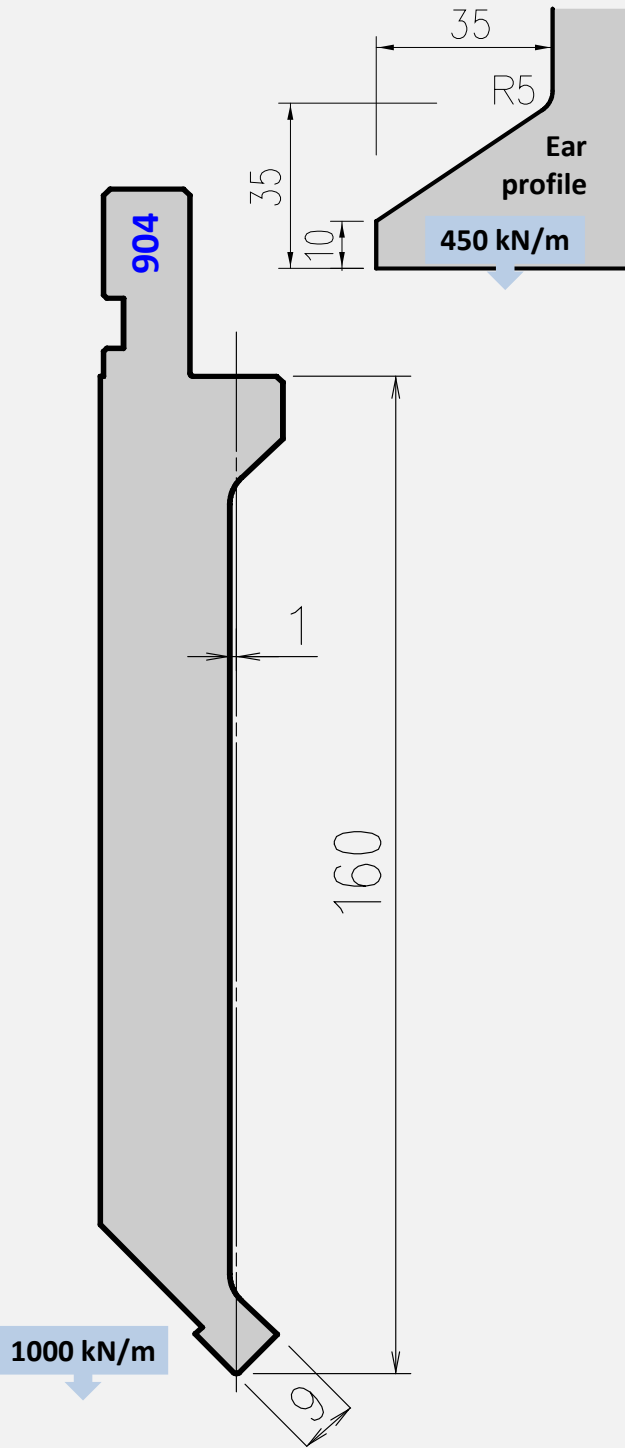

Tool angle	Tip radius	Length mm	Item No.	Wt. Kg
86°	R0.6	835	ES 9048061	22,1
		415	ES 9048062	11,0
		800 Sect	ES 9048063	19,5
	R1.5	835	ES 9048151	22,1
		415	ES 9048152	11,0
		800 Sect	ES 9048153	19,5
	R3	835	ES 9048301	22,1
		415	ES 9048302	11,0
		800 Sect	ES 9048303	19,5
88°	R0.6	835	ES 9047061	22,1
		415	ES 9047062	11,0
		800 Sect	ES 9047063	19,5

Punch 914 replaces old punches [110](#); [113](#)

Tool angle	Tip radius	Length mm	Item No.	Wt. Kg
30°	R0.6	835	ES 9143061	15,1
		415	ES 9143062	7,5
		800 Sect	ES 9143063	13,6

AFH Standard Punch 947

Punch 947 replaces old punch 472

Tool angle	Tip radius	Length mm	Item No.	Weight Kg
86°	R0.6	835	ES 9478061	39,1
		415	ES 9478062	19,4
		800 Sect	ES 9478063	34,3
	R1.5	835	ES 9478151	39,1
		415	ES 9478152	19,4
		800 Sect	ES 9478153	34,3
	R3	835	ES 9478301	39,1
		415	ES 9478302	19,4
		800 Sect	ES 9478303	34,3
88°	R0.6	835	ES 9477061	39,1
		415	ES 9477062	19,4
		800 Sect	ES 9477063	34,3

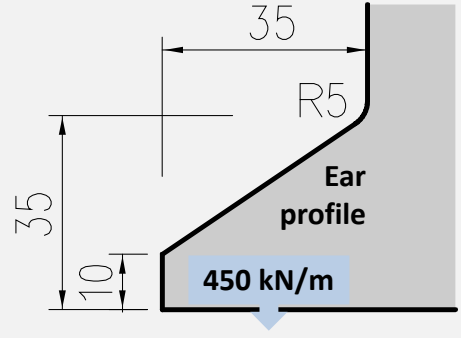
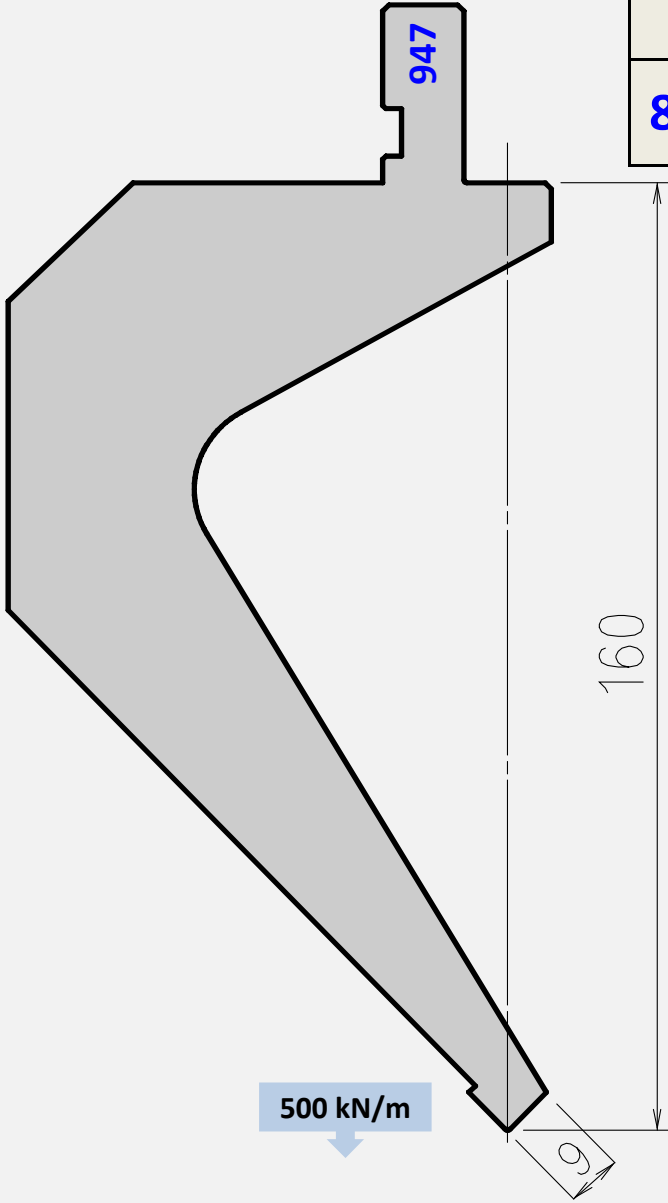

Standard Punch 604 (9 mm tip)

Punch 604 replaces old punch 4

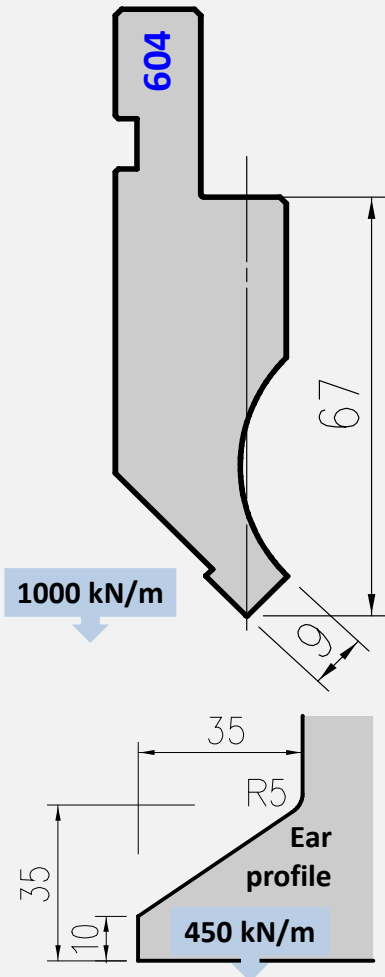

Tool angle	Tip radius	Length mm	Item No.	Weight Kg
88°	R0.2	835	ES 6047021	11,0
		415	ES 6047022	5,5
		800 Sect	ES 6047023	9,7
	R0.6	835	ES 6047061	11,0
		415	ES 6047062	5,5
		800 Sect	ES 6047063	9,7
	R0.8	835	ES 6047081	11,0
		415	ES 6047082	5,5
		800 Sect	ES 6047083	9,7
	R1.5	835	ES 6047151	11,0
		415	ES 6047152	5,5
		800 Sect	ES 6047153	9,7
R3	835	ES 6047301	11,0	
	415	ES 6047302	5,5	
	800 Sect	ES 6047303	9,7	
90°	R0.2	835	ES 6049021	11,0
		415	ES 6049022	5,5
		800 Sect	ES 6049023	9,7
	R0.6	835	ES 6049061	11,0
		415	ES 6049062	5,5
		800 Sect	ES 6049063	9,7

Standard Punch 617 (4 mm tip)

Punch 617 replaces old punch 117

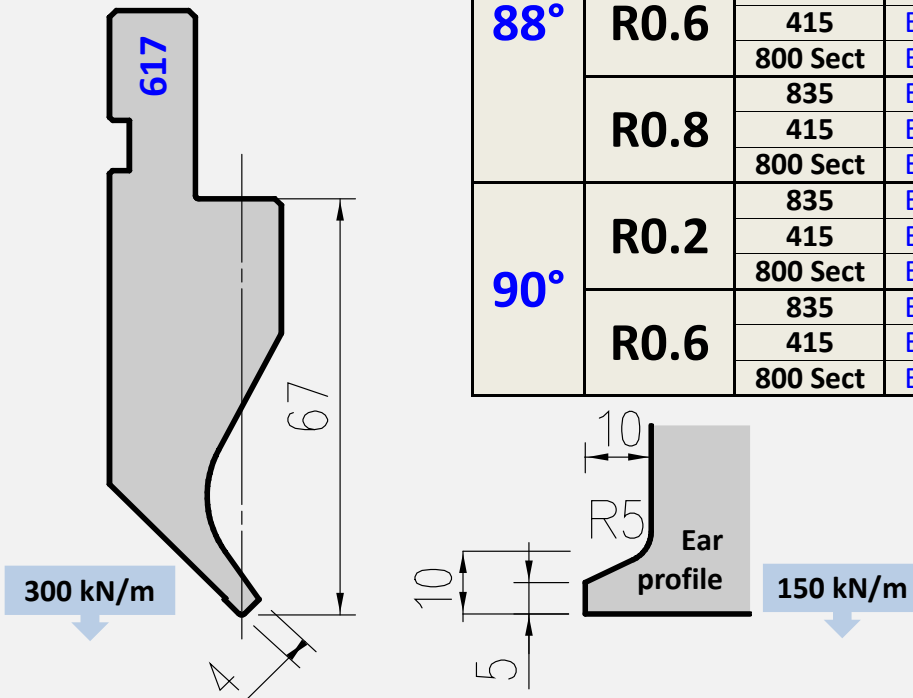

Tool angle	Tip radius	Length mm	Item No.	Weight Kg
88°	R0.2	835	ES 6177021	10,2
		415	ES 6177022	5,1
		800 Sect	ES 6177023	9,1
	R0.6	835	ES 6177061	10,2
		415	ES 6177062	5,1
		800 Sect	ES 6177063	9,1
	R0.8	835	ES 6177081	10,2
		415	ES 6177082	5,1
		800 Sect	ES 6177083	9,1
90°	R0.2	835	ES 6179021	10,2
		415	ES 6179022	5,1
		800 Sect	ES 6179023	9,1
	R0.6	835	ES 6179061	10,2
		415	ES 6179062	5,1
		800 Sect	ES 6179063	9,1

Straight Punch 603

Punch 603 replaces old punch 3

Tool angle	Tip radius	Length mm	Item No.	Weight Kg
60°	R6.0	835	ES 6036601	12,3
		415	ES 6036602	6,1
		800 Sect	ES 6036603	11,1

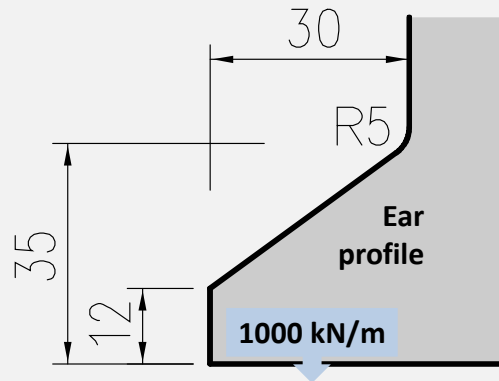
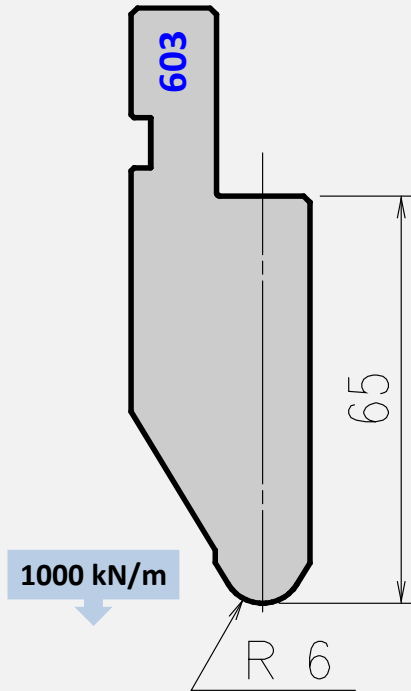

Acute Sash Punch 640

Punch 640 replaces old punch 704

Tool angle	Tip radius	Length mm	Item No.	Weight Kg
60°	R0.8	835	ES 6406081	8,3
		415	ES 6406082	4,1
		800 Sect	ES 6406083	7,6
	R2.0	835	ES 6406201	8,3
		415	ES 6406202	4,1
		800 Sect	ES 6406203	7,6

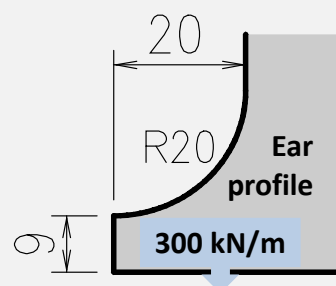
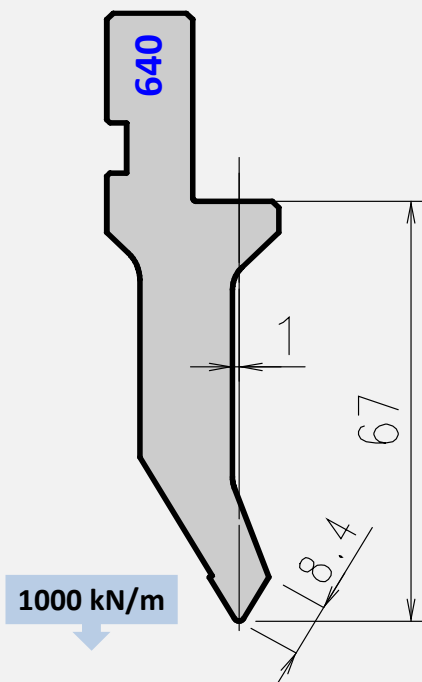

Straight Punch 631

Punch 631 replaces old punches 103 and 8

Tool angle	Tip radius	Length mm	Item No.	Weight Kg
30°	R0.52	835	ES 6313051	8,4
		415	ES 6313052	4,2
		800 Sect	ES 6313053	7,7

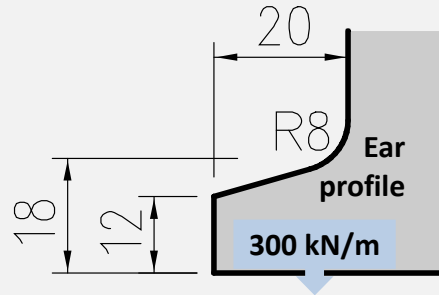
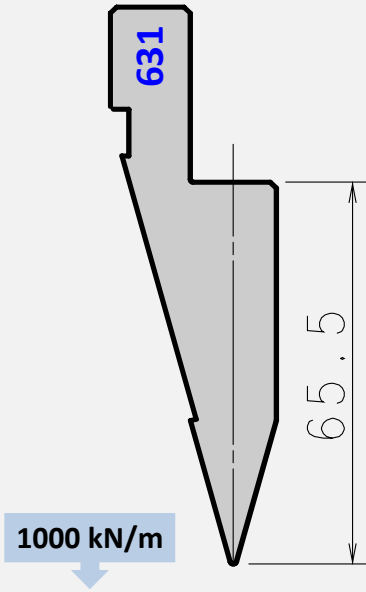

Flattening Punch 622

Punch 622 replaces old punch 220

	Length mm	Item No.	Weight Kg
Flattening	835	ES 6220001	13,5
	415	ES 6220002	6,7

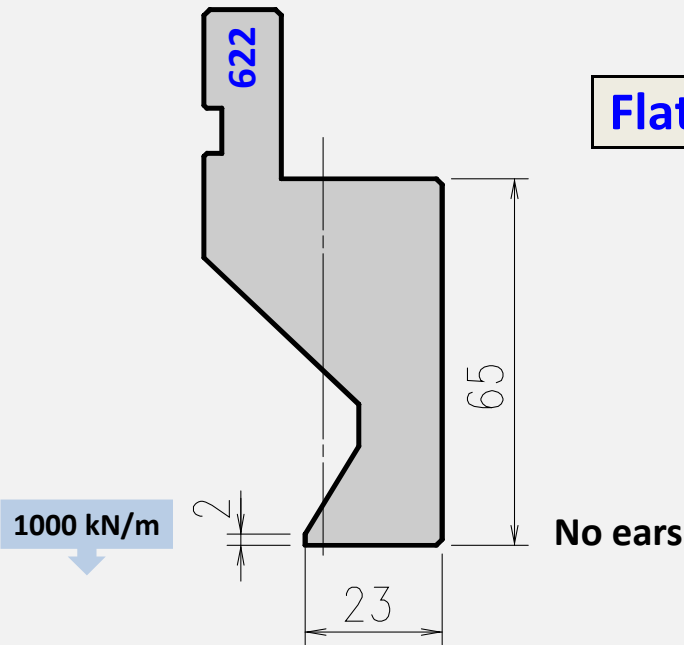

Flattening Punch 020

Punch 020 replaces old punch 20

	Length mm	Item No.	Weight Kg
Flattening	835	ES 0200001	4,5
	415	ES 0200002	2,2

All mounting hardware included.

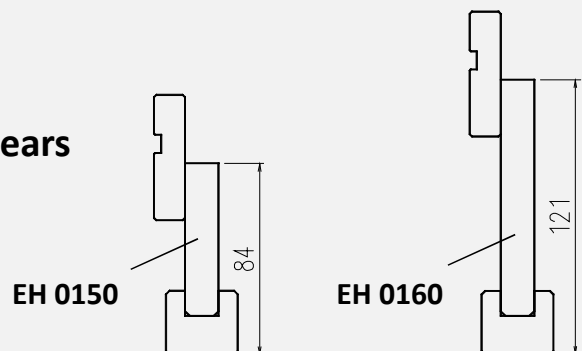
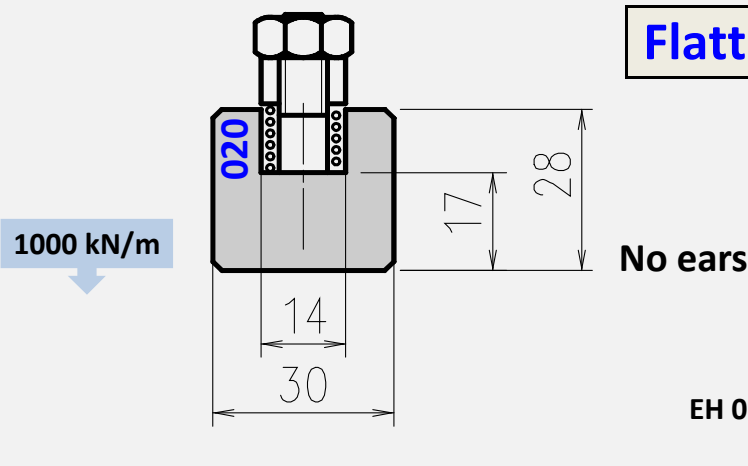

R7 Insert

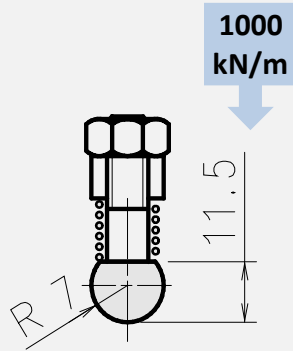

Insert 017007 replaces old insert 01707

L mm	Item No.	Weight Kg
835	ES 0170071	1,0
415	ES 0170072	0,6

R8 Insert

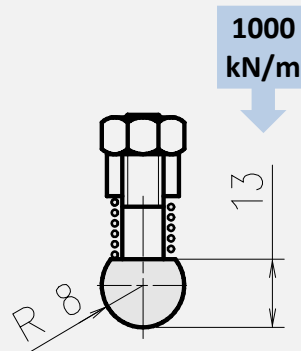

Insert 017008 replaces old insert 01708

L mm	Item No.	Weight Kg
835	ES 0170081	1,5
415	ES 0170082	0,8

R9 Insert

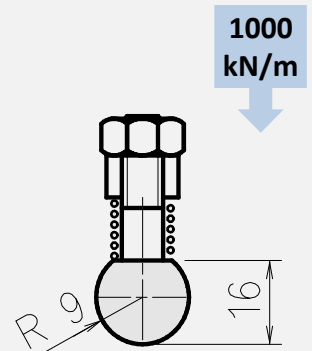

Insert 017009 replaces old insert 01709

L mm	Item No.	Weight Kg
835	ES 0170091	1,9
415	ES 0170092	0,9

R10 Insert

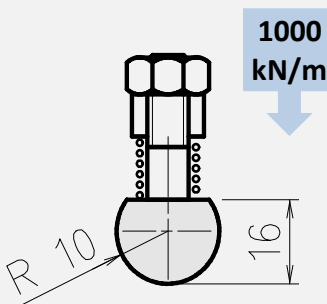

Insert 017010 replaces old insert 01710

L mm	Item No.	Weight Kg
835	ES 0170101	2,1
415	ES 0170102	1,1

R11 Insert

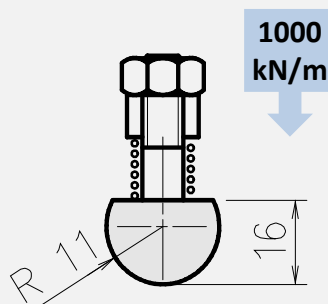

Insert 017011 replaces old insert 01711

L mm	Item No.	Weight Kg
835	ES 0170111	2,3
415	ES 0170112	1,2

R12,5 Insert

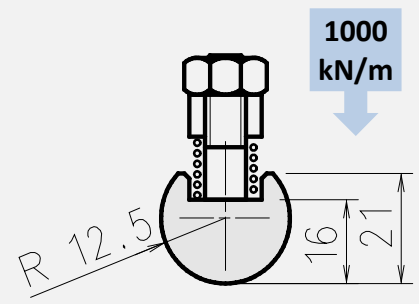

Insert 017012 replaces old insert 01712

L mm	Item No.	Weight Kg
835	ES 0170121	2,7
415	ES 0170122	1,4

R14 Insert

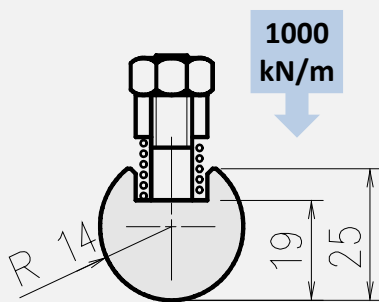

Insert 017014 replaces old insert 01714

L mm	Item No.	Weight Kg
835	ES 0170141	3,6
415	ES 0170142	1,8

R15 Insert

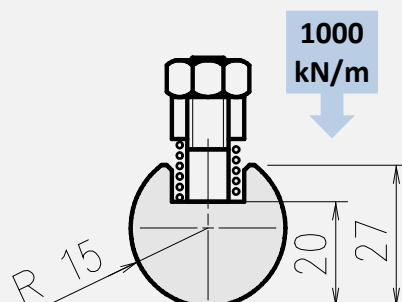

Insert 017015 replaces old insert 01715

L mm	Item No.	Weight Kg
835	ES 0170151	3,7
415	ES 0170152	1,8

R16 Insert

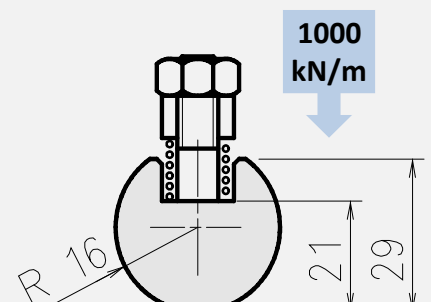

Insert 017016 replaces old insert 01716

L mm	Item No.	Weight Kg
835	ES 0170161	4,6
415	ES 0170162	2,3

Note: Use Radius Inserts with Punch Holder EH 0150 or EH 0160. Mounting hardware is included.

R17,5 Insert

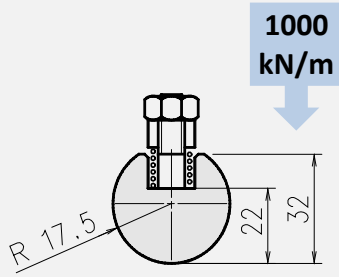

Insert 017017 replaces old insert 01717

L mm	Item No.	Weight Kg
835	ES 0170171	5,1
415	ES 0170172	2,5

R20 Insert

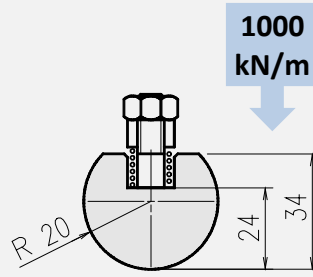

Insert 017020 replaces old insert 01720

L mm	Item No.	Weight Kg
835	ES 0170201	6,5
415	ES 0170202	3,2

R22,5 Insert

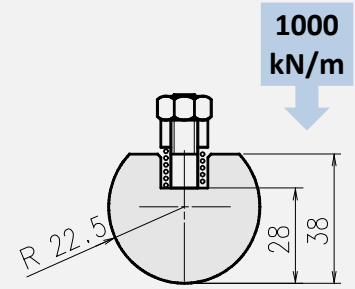

Insert 017022 replaces old insert 01722

L mm	Item No.	Weight Kg
835	ES 0170221	8,8
415	ES 0170222	4,4

R25 Insert

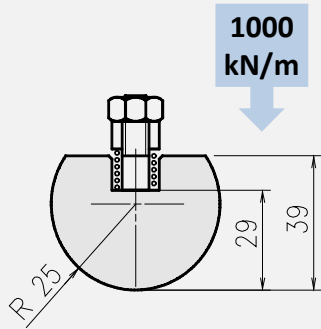

Insert 017025 replaces old insert 01725

L mm	Item No.	Weight Kg
835	ES 0170251	9,8
415	ES 0170252	4,8

R30 Insert

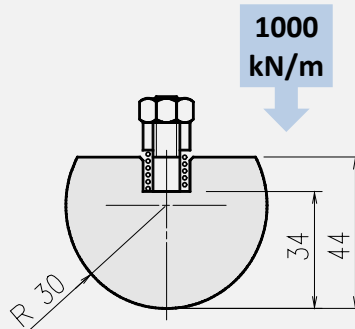

Insert 017030 replaces old insert 01730

L mm	Item No.	Weight Kg
835	ES 0170301	13,6
415	ES 0170302	6,8

R35 Insert

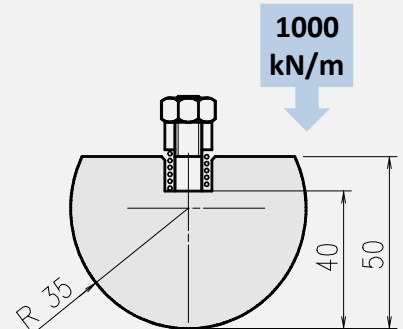

Insert 017035 replaces old insert 01735

L mm	Item No.	Weight Kg
835	ES 0170351	18,5
415	ES 0170352	9,2

R40 Insert

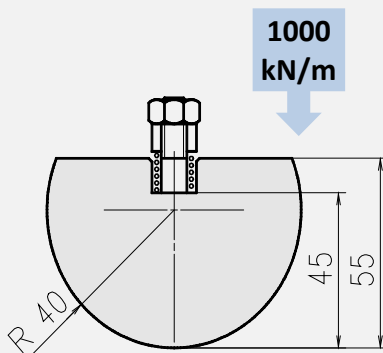

Insert 017040 replaces old insert 01740

L mm	Item No.	Weight Kg
835	ES 0170401	23,3
415	ES 0170402	11,6

R45 Insert

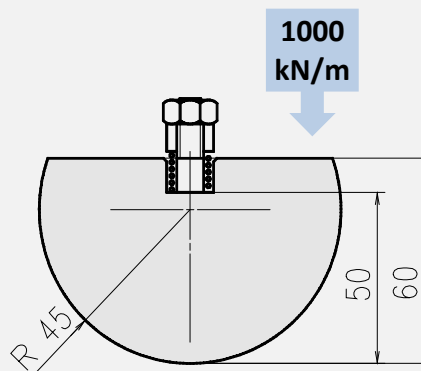

Insert 017045 replaces old insert 01745

L mm	Item No.	Weight Kg
835	ES 0170451	28,7
415	ES 0170452	14,3

R50 Insert

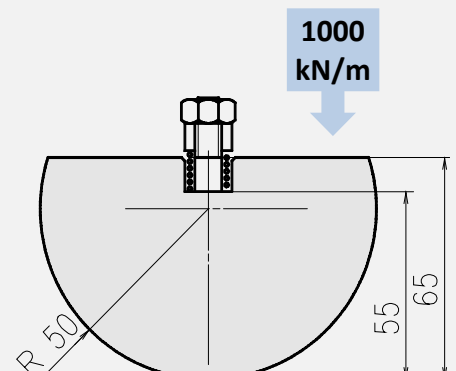

Insert 017050 replaces old insert 01750

L mm	Item No.	Weight Kg
835	ES 0170501	34,6
415	ES 0170502	17,2

Note: Use Radius Inserts with Punch Holder EH 0150 or EH 0160. Mounting hardware is included.

Punch Holder : 91

Sect. 835mm = 2x100ear
 20; 25; 30
 35; 40; 50
 70; 165; 200

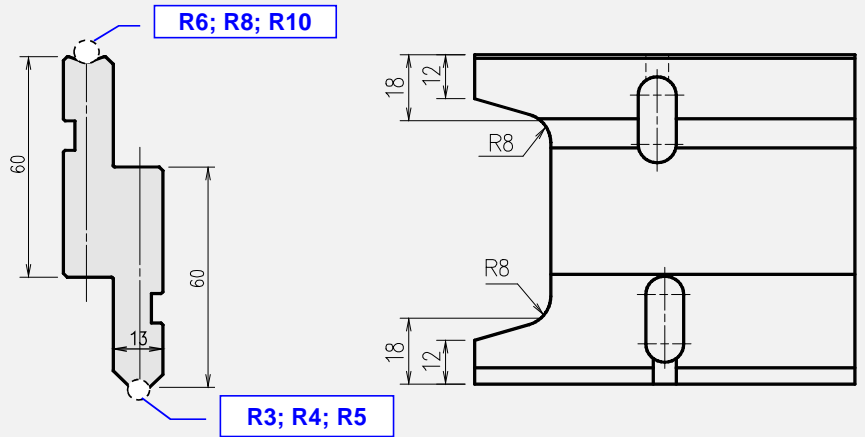
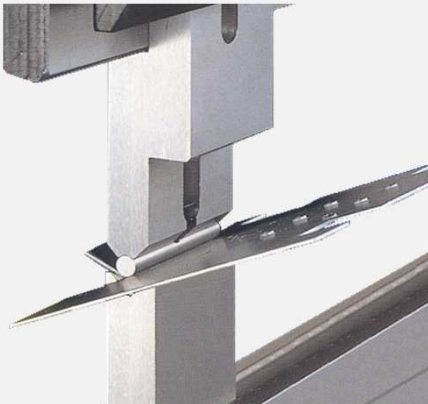

Tonnage:

- 1000 kN/m for 835 and 415 tools
 - 150 kN/m for Sect. tools

L mm	Item No.	Weight Kg
835	DX 091001	10,0
415	DX 091002	5,0
Sect.	DX 091801	10,0

R3 Insert

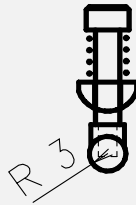

L mm	Item No.	Weight Kg
835	DX 090301	0,2
415	DX 090302	0,1
Sect.	DX 090831	0,2

R4 Insert

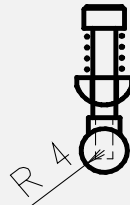

L mm	Item No.	Weight Kg
835	DX 090401	0,3
415	DX 090402	0,1
Sect.	DX 090841	0,3

R5 Insert

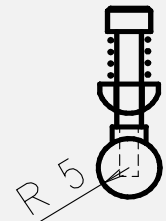

L mm	Item No.	Weight Kg
835	DX 090501	0,5
415	DX 090502	0,2
Sect.	DX 090851	0,5

R6 Insert

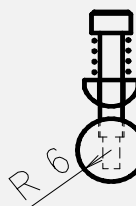

L mm	Item No.	Weight Kg
835	DX 090601	0,7
415	DX 090602	0,3
Sect.	DX 090861	0,7

R8 Insert

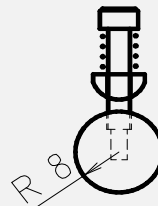

L mm	Item No.	Weight Kg
835	DX 090801	1,3
415	DX 090802	0,6
Sect.	DX 090881	1,3

R10 Insert

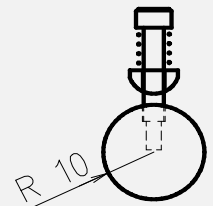

L mm	Item No.	Weight Kg
835	DX 090101	2,1
415	DX 090102	1,0
Sect.	DX 090811	2,1

Colour-Multi-Radius

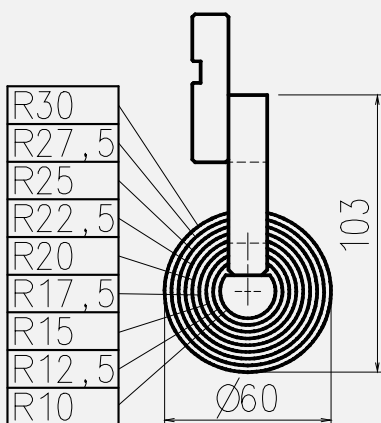

Sect. 835mm =
 25; 40; 50
 100; 120
 200; 300

500 kN/m

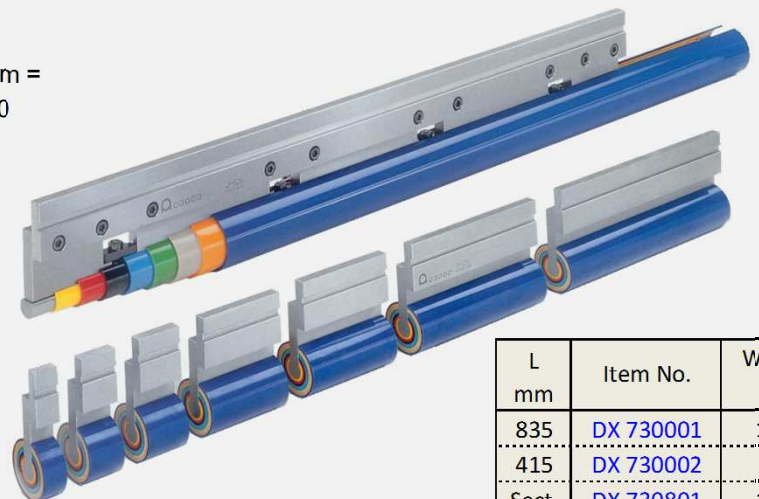

L mm	Item No.	Weight Kg
835	DX 730001	13,0
415	DX 730002	6,4
Sect.	DX 730801	13,0

AFH Standard Die 0703 (V 6)

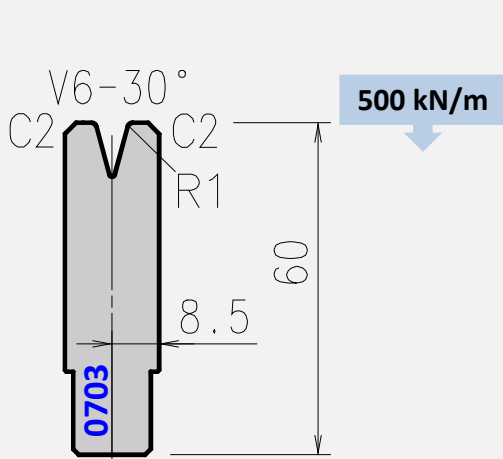

Die 0703 replaces old dies 14006 and A7003

Tool angle	Length mm	Item No.	Weight Kg
30°	835	ED 0703101	6,0
	415	ED 0703102	3,0
	800 sect.	ED 0703103	5,7

Staged* Die 1703 (V 6)

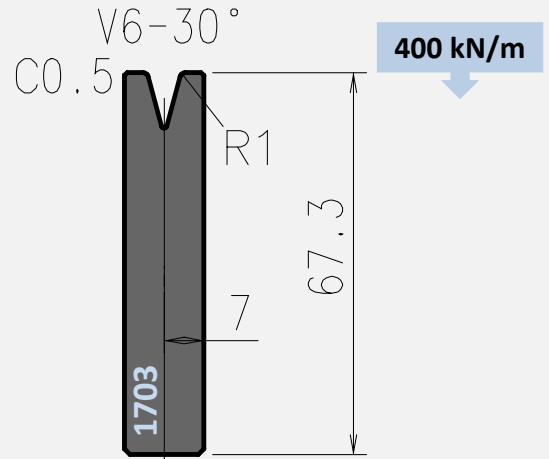

Die 1703 replaces old die S7030

Tool angle	Length mm	Item No.	Weight Kg
30° staged	835	ED 1703101	5,9
	415	ED 1703102	3,0
	800 sect.	ED 1703103	5,7

AFH Standard Die 0713 (V 8)

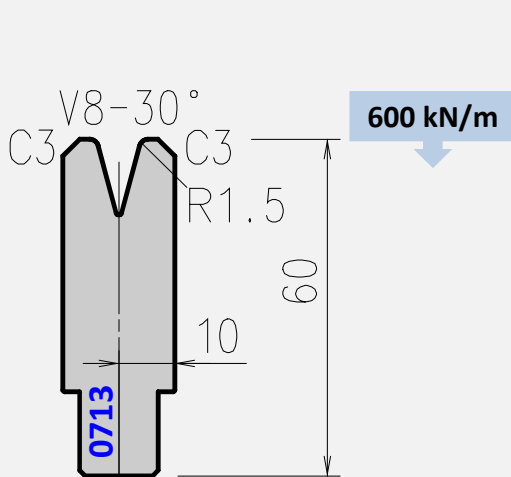

Die 0713 replaces old dies 14100 and A7103

Tool angle	Length mm	Item No.	Weight Kg
30°	835	ED 0713151	6,8
	415	ED 0713152	3,4
	800 sect.	ED 0713153	6,5

Staged* Die 1713 (V 8)

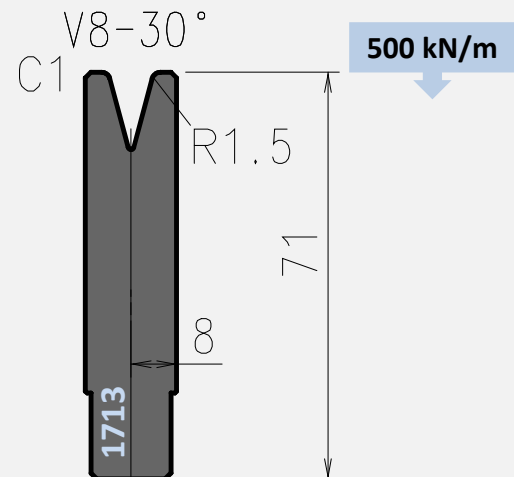

Die 1713 replaces old die S7130

Tool angle	Length mm	Item No.	Weight Kg
30° staged	835	ED 1713151	6,8
	415	ED 1713152	3,4
	800 sect.	ED 1713153	6,5



AFH Standard Die 0723 (V 10)

Staged* Die 1723 (V 10)

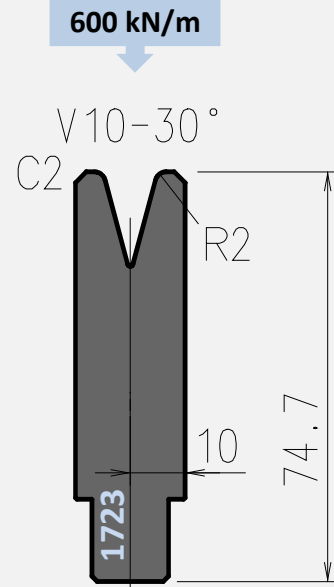
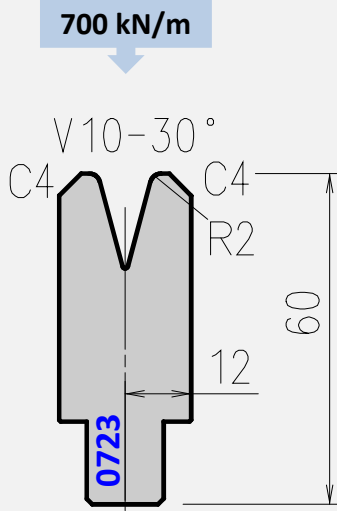

Die 0723 replaces old dies 14106 and A7203

Tool angle	Length mm	Item No.	Weight Kg
30°	835	ED 0723201	7,7
	415	ED 0723202	3,8
	800 sect.	ED 0723203	7,4

Die 1723 replaces old die S7230

Tool angle	Length mm	Item No.	Weight Kg
30° staged	835	ED 1723201	8,3
	415	ED 1723202	4,2
	800 sect.	ED 1723203	8,0

AFH Standard Die 0743 (V 12)

Staged* Die 1743 (V 12)

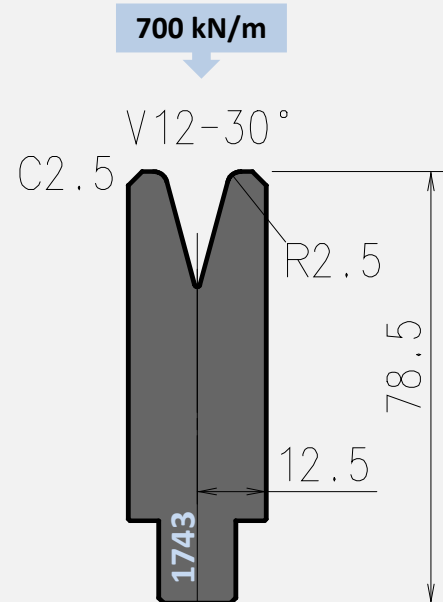
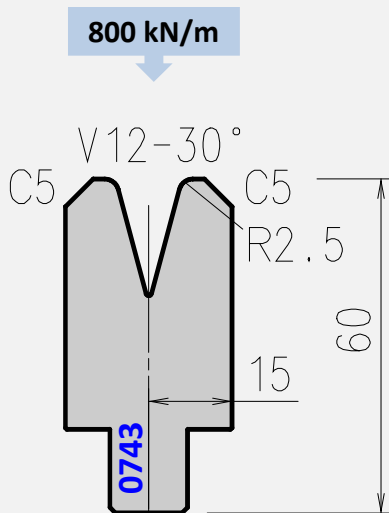

Die 0743 replaces old dies 14200 and A7403

Tool angle	Length mm	Item No.	Weight Kg
30°	835	ED 0743251	9,1
	415	ED 0743252	4,5
	800 sect.	ED 0743253	8,7

Die 1713 replaces old die S7430

Tool angle	Length mm	Item No.	Weight Kg
30° staged	835	ED 1743251	10,5
	415	ED 1743252	5,2
	800 sect.	ED 1743253	10,0

AFH Standard Die 0773 (V 16)

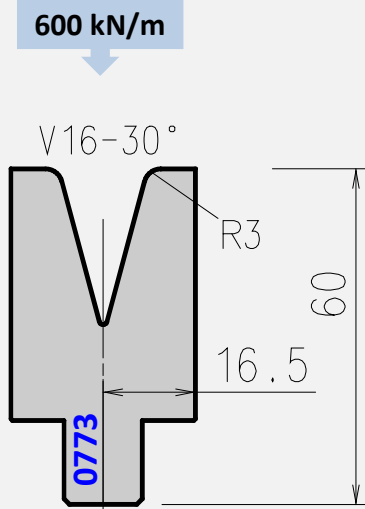

Die 0773 replaces old die 14206

Tool angle	Length mm	Item No.	Weight Kg
30°	835	ED 0773301	9,7
	415	ED 0773302	4,8
	800 sect.	ED 0773303	9,3

Standard Die 0793 (V 20)

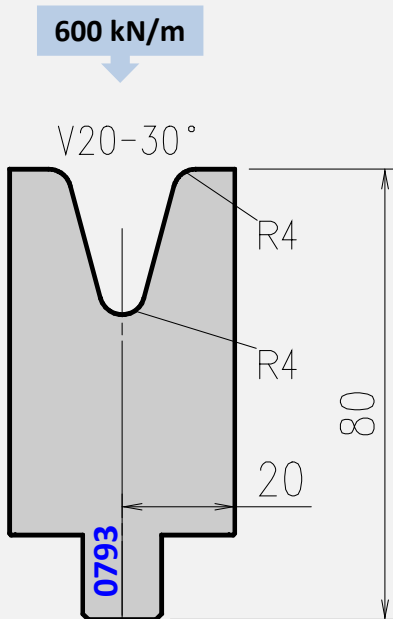

Die 0793 replaces old die 14300

Tool angle	Length mm	Item No.	Weight Kg
30°	835	ED 0793401	16,4
	415	ED 0793402	8,2
	800 sect.	ED 0793403	15,7

Standard Die 0823 (V 25)

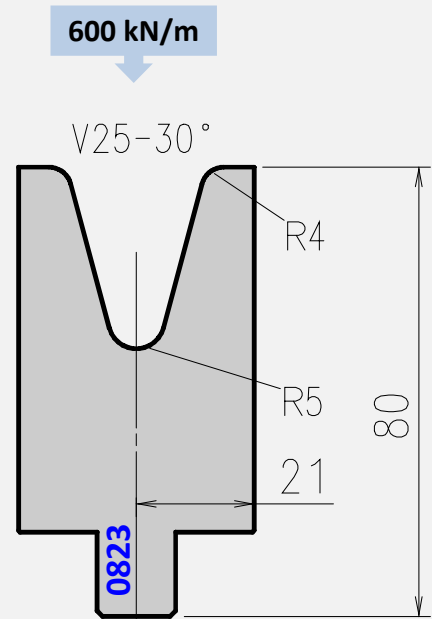

Die 0823 replaces old die 14306

Tool angle	Length mm	Item No.	Weight Kg
30°	835	ED 0823401	15,8
	415	ED 0823402	7,8
	800 sect.	ED 0823403	15,1

Standard Die 0871 (V 32)

Standard Die 0881 (V 40)

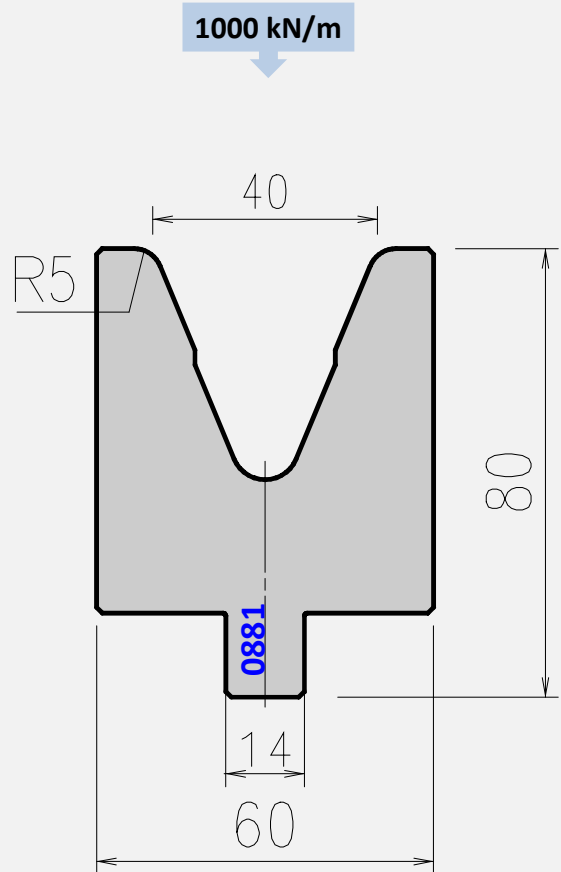
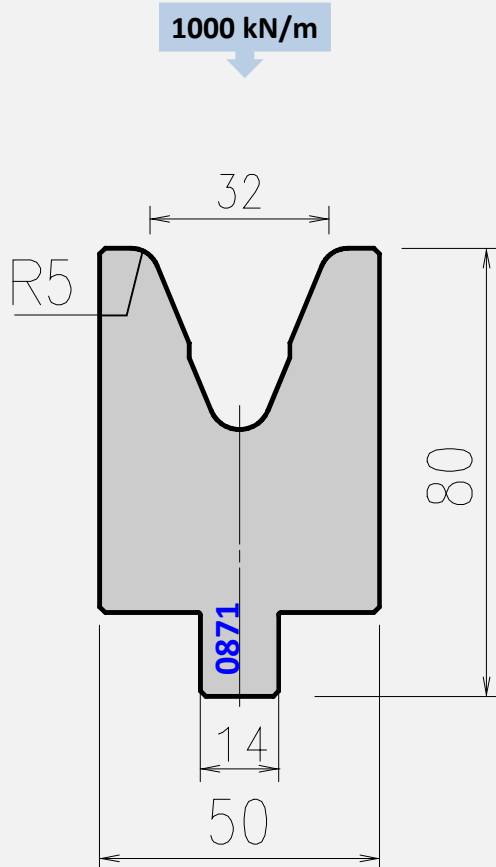

Die 0871 replaces old die 28700

Tool angle	Length mm	Item No.	Weight Kg
45°	835	ED 0871501	18,2
	415	ED 0871502	9,1
	800 sect.	ED 0871503	17,4

Die 0881 replaces old die 28800

Tool angle	Length mm	Item No.	Weight Kg
45°	835	ED 0881501	20,1
	415	ED 0881502	10,0
	800 sect.	ED 0881503	19,3

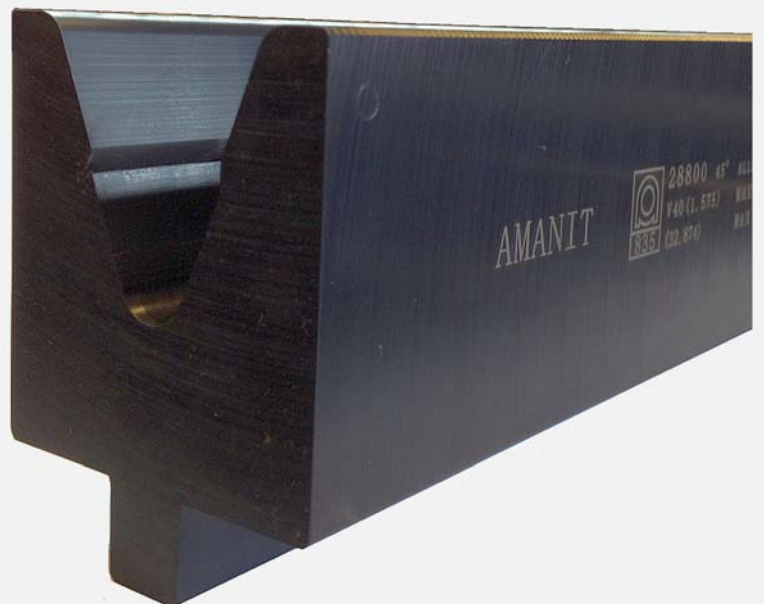

AFH Die 0706 (V 6)

AFH Die 0716 (V 8)

380 kN/m

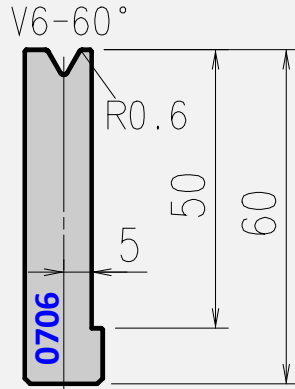

450 kN/m

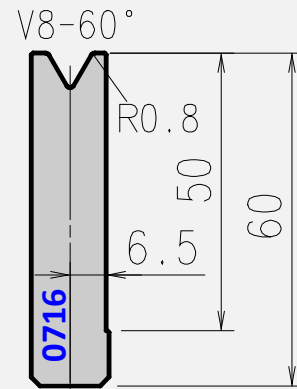

Die 0706 replaces old die 1700

Tool angle	Length mm	Item No.	Weight Kg
60°	835	ED 0706061	4,7
	415	ED 0706062	2,4
	800 sect.	ED 0706063	4,5

Die 0716 replaces old die 17100

Tool angle	Length mm	Item No.	Weight Kg
60°	835	ED 0716081	5,1
	415	ED 0716082	2,5
	800 sect.	ED 0716083	4,9

AFH Die 0726 (V 10)

AFH Die 0746 (V 12)

550 kN/m

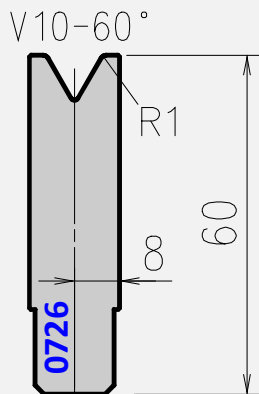

550 kN/m

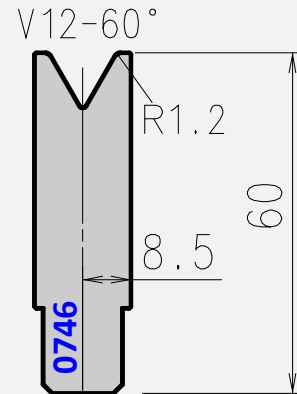

Die 0726 replaces old die 17200

Tool angle	Length mm	Item No.	Weight Kg
60°	835	ED 0726101	5,8
	415	ED 0726102	2,9
	800 sect.	ED 0726103	5,5

Die 0746 replaces old die 17400

Tool angle	Length mm	Item No.	Weight Kg
60°	835	ED 0746121	5,9
	415	ED 0746122	3,0
	800 sect.	ED 0746123	5,7

AFH Die 0776 (V 16)

AFH Die 0796 (V 20)

650 kN/m

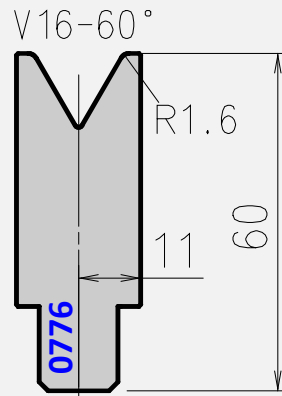

850 kN/m

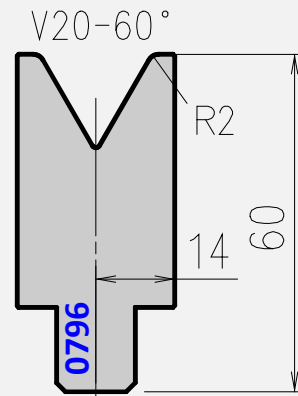

Die 0776 replaces old die 17700

Tool angle	Length mm	Item No.	Weight Kg
60°	835	ED 0776161	7,1
	415	ED 0776162	3,5
	800 sect.	ED 0776163	6,8

Die 0796 replaces old die 17900

Tool angle	Length mm	Item No.	Weight Kg
60°	835	ED 0796201	8,4
	415	ED 0796202	4,2
	800 sect.	ED 0796203	8,1

AFH Die 0826 (V 25)

850 kN/m

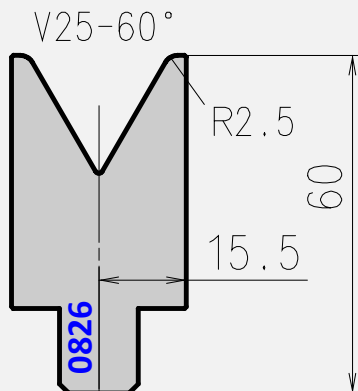

Die 0826 replaces old die 18200

Tool angle	Length mm	Item No.	Weight Kg
60°	835	ED 0826251	8,7
	415	ED 0826252	4,3
	800 sect.	ED 0826253	8,3

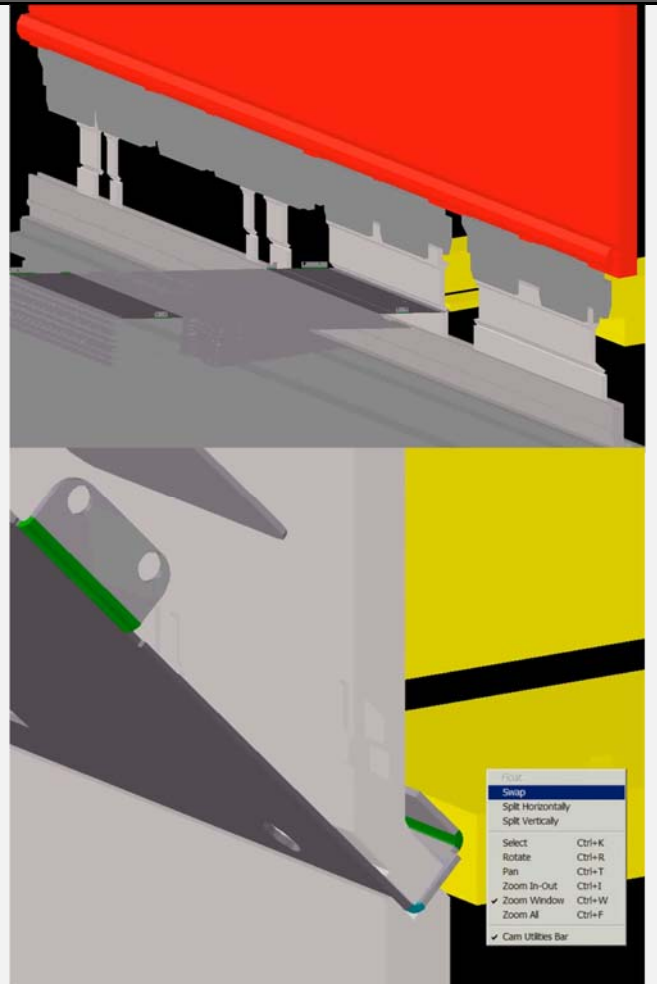

Four	
Swap	
Split Horizontally	
Split Vertically	
Select	Ctrl+K
Rotate	Ctrl+R
Pan	Ctrl+T
Zoom In-Out	Ctrl+I
Zoom Window	Ctrl+W
Zoom All	Ctrl+F
✓ Cam Utilities Bar	

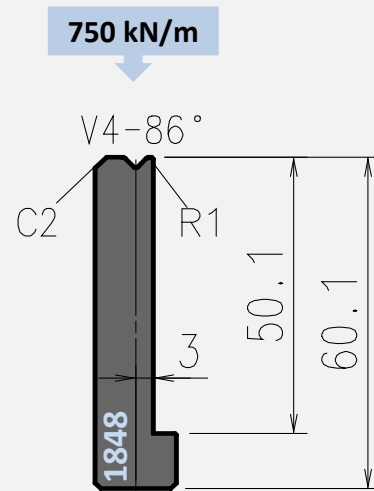
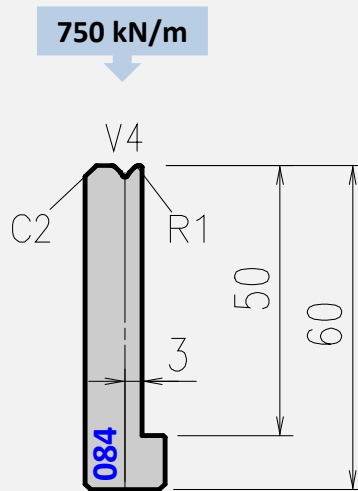
AFH Standard Die 084 (V 4)
Staged* Die 1848 (V 4)

Die 084 replaces old dies 084 and A840

Tool angle	Length mm	Item No.	Weight Kg
86°	835	ED 0848101	4,1
	415	ED 0848102	2,1
	800 sect.	ED 0848103	4,0
88°	835	ED 0847101	4,1
	415	ED 0847102	2,1
	800 sect.	ED 0847103	4,0
90°	835	ED 0849101	4,1
	415	ED 0849102	2,1
	800 sect.	ED 0849103	4,0

Die 1848 replaces old die S848

Tool angle	Length mm	Item No.	Weight Kg
86° staged	835	ED 1848101	4,3
	415	ED 1848102	2,2
	800 sect.	ED 1848103	4,1

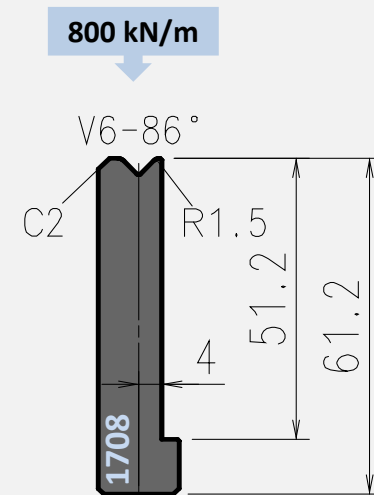
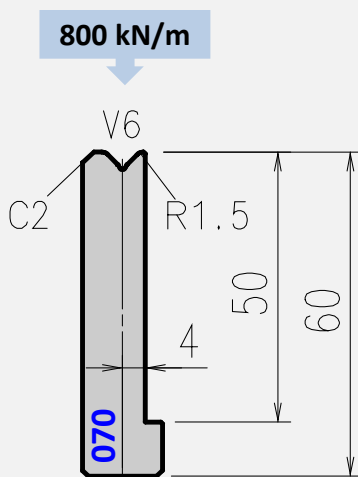
AFH Standard Die 070 (V 6)
Staged* Die 1708 (V 6)

Die 070 replaces old dies 070 and A700

Tool angle	Length mm	Item No.	Weight Kg
86°	835	ED 0708151	4,4
	415	ED 0708152	2,2
	800 sect.	ED 0708153	4,2
88°	835	ED 0707151	4,4
	415	ED 0707152	2,2
	800 sect.	ED 0707153	4,2
90°	835	ED 0709151	4,4
	415	ED 0709152	2,2
	800 sect.	ED 0709153	4,2

Die 1708 replaces old die S708

Tool angle	Length mm	Item No.	Weight Kg
86° staged	835	ED 1708151	4,6
	415	ED 1708152	2,3
	800 sect.	ED 1708153	4,4

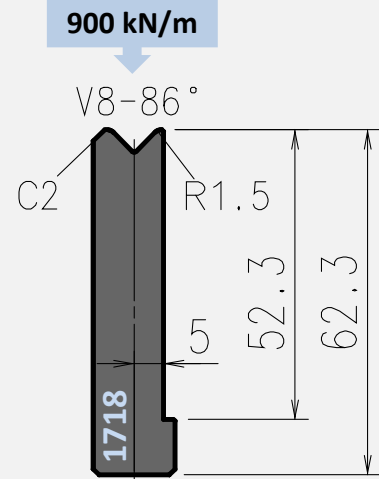
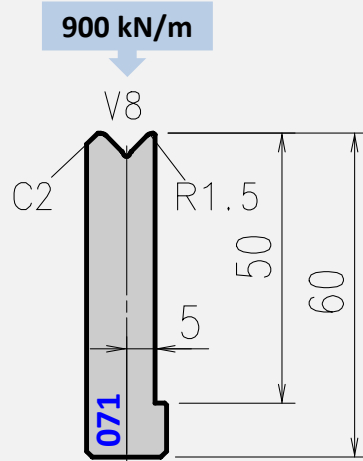
AFH Standard Die 071 (V 8)
Staged* Die 1718 (V 8)

Die 071 replaces old dies 071 and A710

Tool angle	Length mm	Item No.	Weight Kg
86°	835	ED 0718151	4,7
	415	ED 0718152	2,3
	800 sect.	ED 0718153	4,5
88°	835	ED 0717151	4,7
	415	ED 0717152	2,3
	800 sect.	ED 0717153	4,5
90°	835	ED 0719151	4,7
	415	ED 0719152	2,3
	800 sect.	ED 0719153	4,5

Die 1718 replaces old die S718

Tool angle	Length mm	Item No.	Weight Kg
86° staged	835	ED 1718151	4,9
	415	ED 1718152	2,5
	800 sect.	ED 1718153	4,7

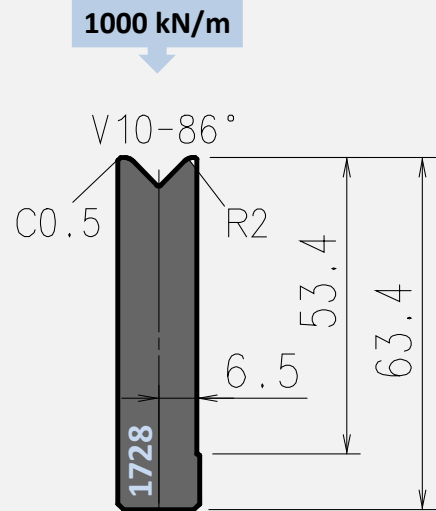
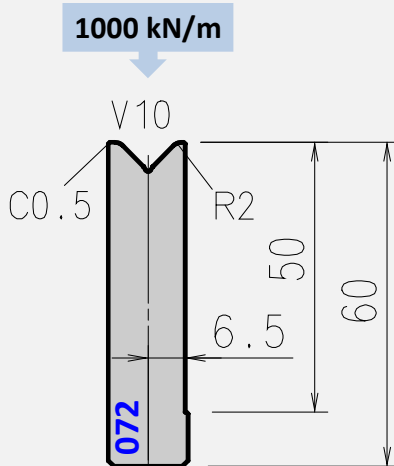
AFH Standard Die 072 (V 10)
Staged* Die 1728 (V 10)

Die 072 replaces old dies 072 and A720

Tool angle	Length mm	Item No.	Weight Kg
86°	835	ED 0728201	5,2
	415	ED 0728202	2,6
	800 sect.	ED 0728203	4,9
88°	835	ED 0727201	5,2
	415	ED 0727202	2,6
	800 sect.	ED 0727203	4,9
90°	835	ED 0729201	5,2
	415	ED 0729202	2,6
	800 sect.	ED 0729203	4,9

Die 1728 replaces old die S728

Tool angle	Length mm	Item No.	Weight Kg
86° staged	835	ED 1728201	5,4
	415	ED 1728202	2,7
	800 sect.	ED 1728203	5,2

AFH Standard Die 074 (V 12)

Staged* Die 1748 (V 12)

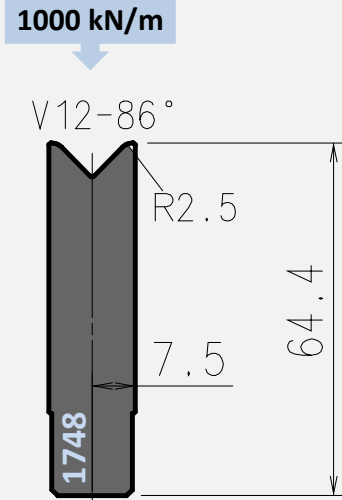
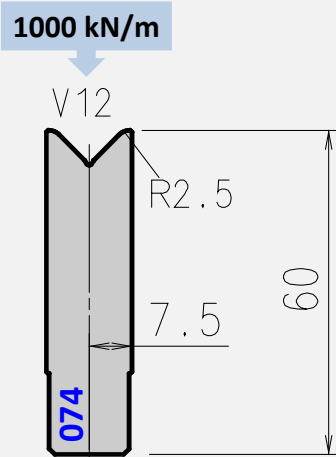

Die 074 replaces old dies 074 and A740

Tool angle	Length mm	Item No.	Weight Kg
86°	835	ED 0748251	5,5
	415	ED 0748252	2,7
	800 sect.	ED 0748253	5,3
88°	835	ED 0747251	5,5
	415	ED 0747252	2,7
	800 sect.	ED 0747253	5,3
90°	835	ED 0749251	5,5
	415	ED 0749252	2,7
	800 sect.	ED 0749253	5,3

Die 1748 replaces old die S748

Tool angle	Length mm	Item No.	Weight Kg
86° staged	835	ED 1748251	5,8
	415	ED 1748252	2,9
	800 sect.	ED 1748253	5,6

AFH Standard Die 076 (V 14)

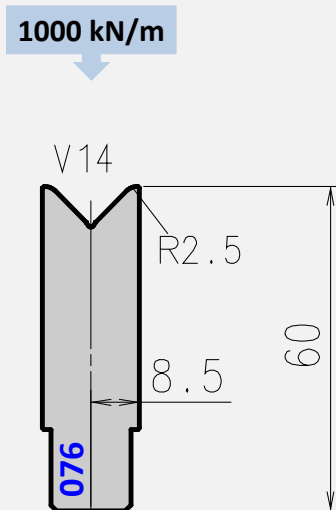

Die 076 replaces old dies 076 and A760

Tool angle	Length mm	Item No.	Weight Kg
86°	835	ED 0768251	6,0
	415	ED 0768252	3,0
	800 sect.	ED 0768253	5,8
88°	835	ED 0767251	6,0
	415	ED 0767252	3,0
	800 sect.	ED 0767253	5,8

AFH Standard Die 077 (V 16)

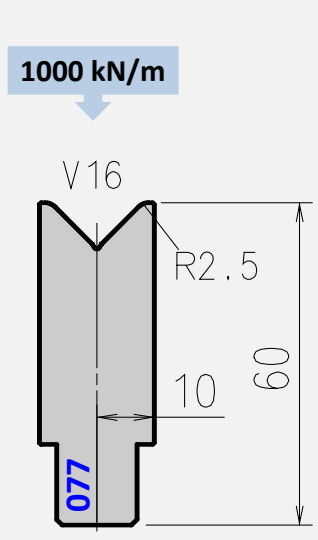

Die 077 replaces old dies 077 and A770

Tool angle	Length mm	Item No.	Weight Kg
86°	835	ED 0778251	6,8
	415	ED 0778252	3,4
	800 sect.	ED 0778253	6,5
88°	835	ED 0777251	6,8
	415	ED 0777252	3,4
	800 sect.	ED 0777253	6,5

Staged* Die 1778 (V 16)

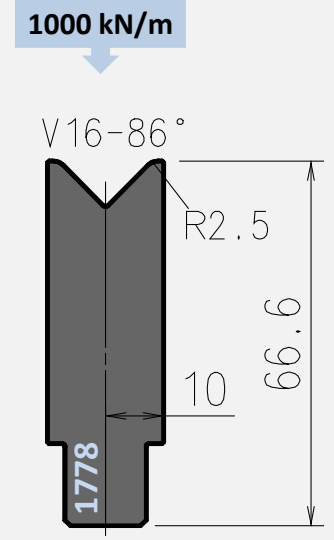

Die 1778 replaces old die S778

Tool angle	Length mm	Item No.	Weight Kg
86° staged	835	ED 1778251	7,4
	415	ED 1778252	3,7
	800 sect.	ED 1778253	7,1

AFH Standard Die 078 (V 18)

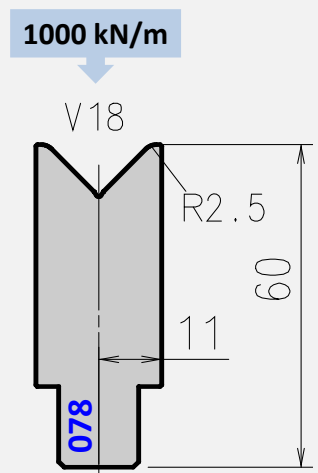

Die 078 replaces old dies 078 and A780

Tool angle	Length mm	Item No.	Weight Kg
86°	835	ED 0788251	7,3
	415	ED 0788252	3,6
	800 sect.	ED 0788253	7,0
88°	835	ED 0787251	7,3
	415	ED 0787252	3,6
	800 sect.	ED 0787253	7,0



AFH Standard Die 079 (V 20) **Staged* Die 1798 (V 20)**

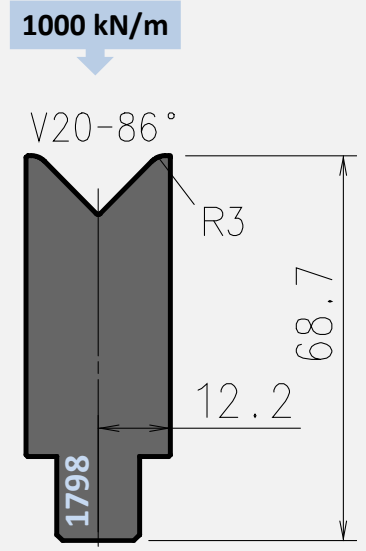
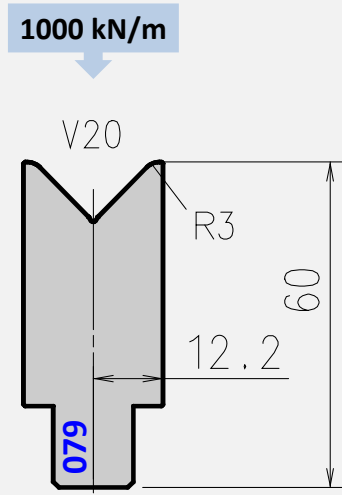

Die 079 replaces old dies 079 and A790

Tool angle	Length mm	Item No.	Weight Kg
86°	835	ED 0798301	7,8
	415	ED 0798302	3,9
	800 sect.	ED 0798303	7,5
88°	835	ED 0797301	7,8
	415	ED 0797302	3,9
	800 sect.	ED 0797303	7,5

Die 1798 replaces old die S798

Tool angle	Length mm	Item No.	Weight Kg
86° staged	835	ED 1798301	8,9
	415	ED 1798302	4,4
	800 sect.	ED 1798303	8,5

AFH Standard Die 082 (V 25) **Staged* Die 1828 (V 25)**

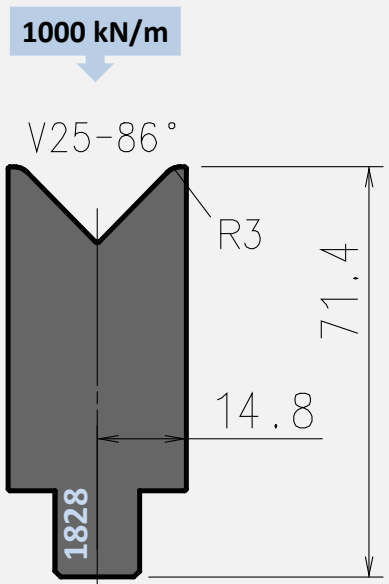
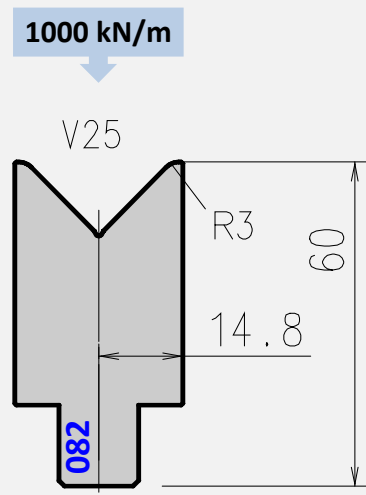

Die 082 replaces old dies 082 and A820

Tool angle	Length mm	Item No.	Weight Kg
86°	835	ED 0828301	9,0
	415	ED 0828302	4,5
	800 sect.	ED 0828303	8,6
88°	835	ED 0827301	9,0
	415	ED 0827302	4,5
	800 sect.	ED 0827303	8,6

Die 1828 replaces old die S828

Tool angle	Length mm	Item No.	Weight Kg
86° staged	835	ED 1828301	10,6
	415	ED 1828302	5,3
	800 sect.	ED 1828303	10,2

AFH Standard Die 0874 (V 32)

AFH Standard Die 0884 (V 40)

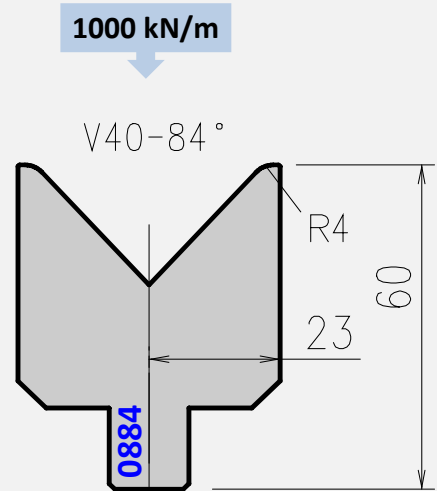
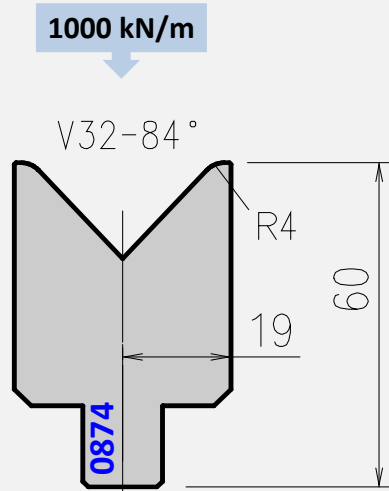

Die 0874 replaces old die A870

Tool angle	Length mm	Item No.	Weight Kg
84°	835	ED 0874401	10,6
	415	ED 0874402	5,3
	800 sect.	ED 0874403	10,2

Die 0884 replaces old die A880

Tool angle	Length mm	Item No.	Weight Kg
84°	835	ED 0884401	11,8
	415	ED 0884402	5,9
	800 sect.	ED 0884403	11,3

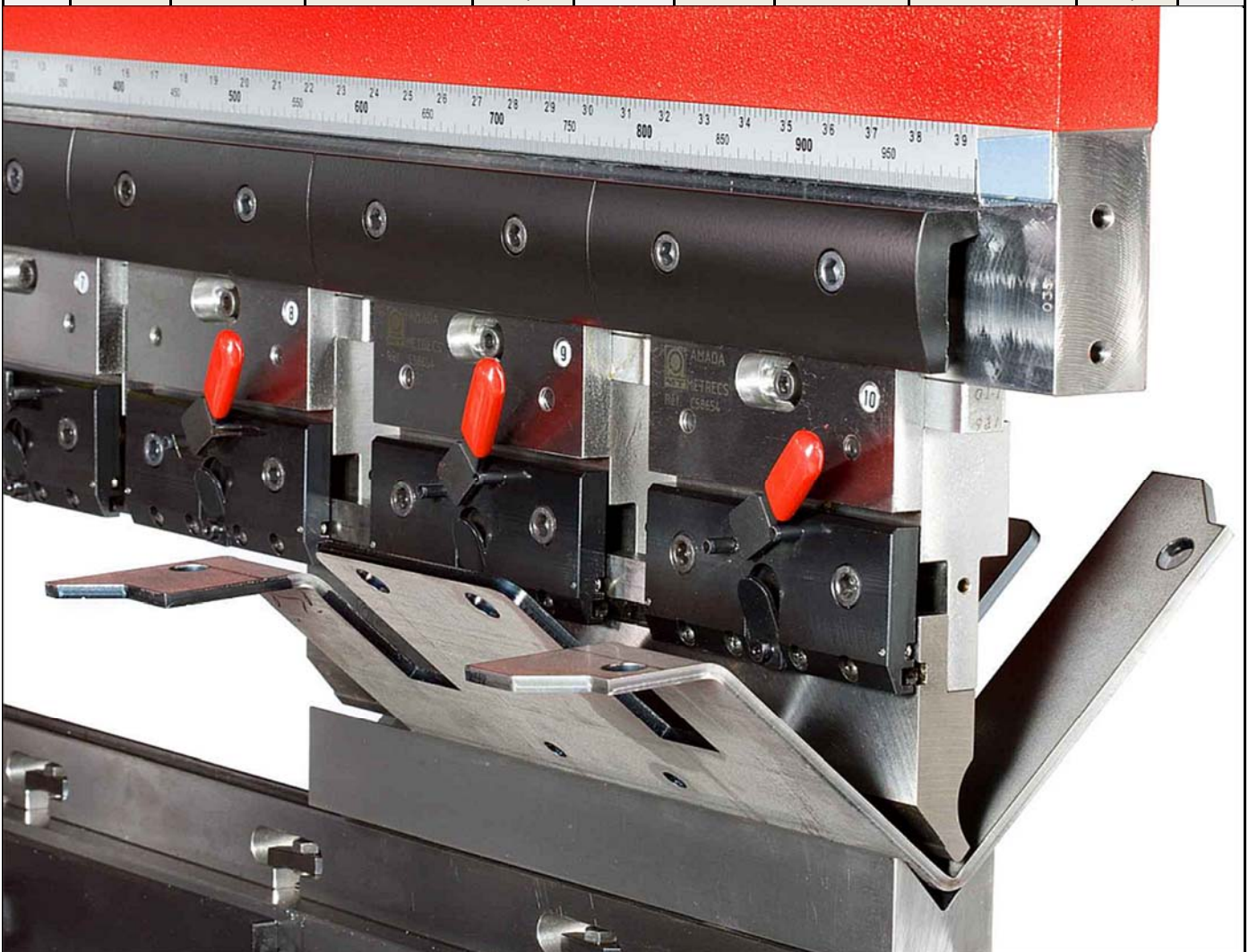

Staged Punch Holder 0282 (to use with H90 mm punches)

Staged Punch Holder 0582 (to use with H120 mm punches)

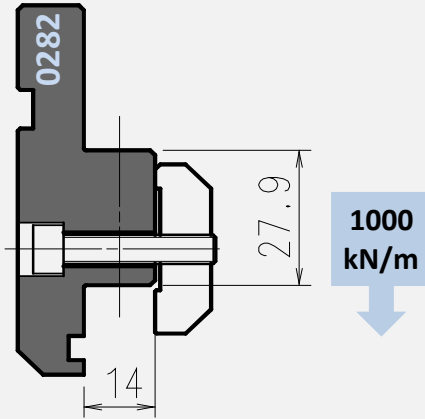

Holder 0282 replaces old holder SPH282

Length mm	Item No.	Weight Kg
415	EH 0282002	5,3

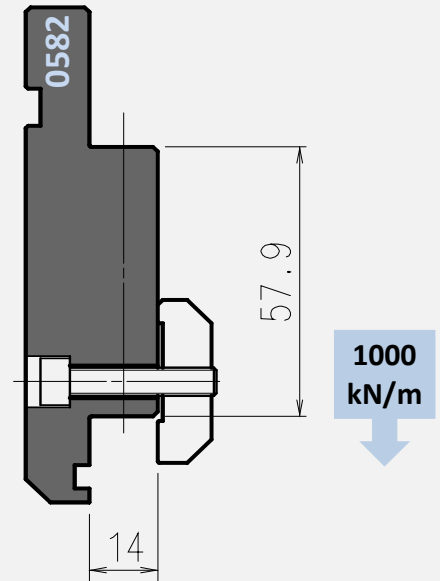

Holder 0582 replaces old holder SPH582

Length mm	Item No.	Weight Kg
415	EH 0582002	7,9

Staged Hemming Tool 1600

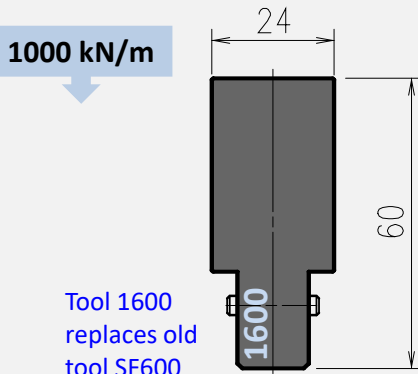

Tool 1600 replaces old tool SF600

Length mm	Item No.	Weight Kg
835	ED 1600001	8,0
415	ED 1600002	4,0
800 sect.	ED 1600003	7,7

Notes:

1. Staged hemming tool is reversible and can be mounted on punch or die holder. Depending on thrust force direction tool stops are needed on punch side or on die side.
2. Flattening involves high thrust forces, therefore it's sequence always needs an intermittent stroke.

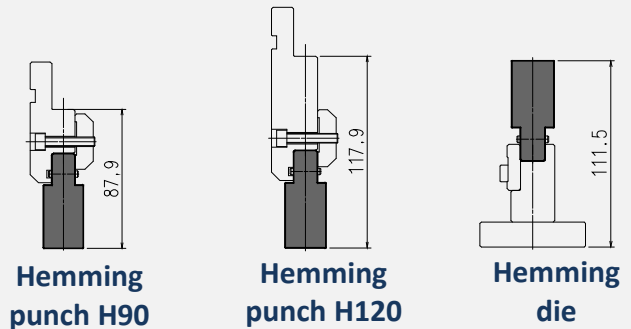

Tool Stop for flattening

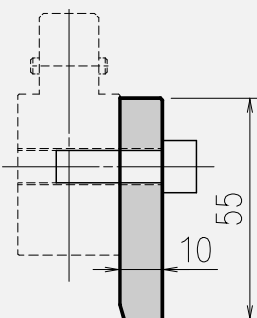

Note:

Tool stop prevents thrust forces from affecting the rest of tooling system.

Tool stop 1600 replaces old tool stop SF601

Length mm	Item No.	Weight Kg
for 835	ED 1600011	3,7
for 415	ED 1600012	1,8
for sect.	ED 1600013	3,5

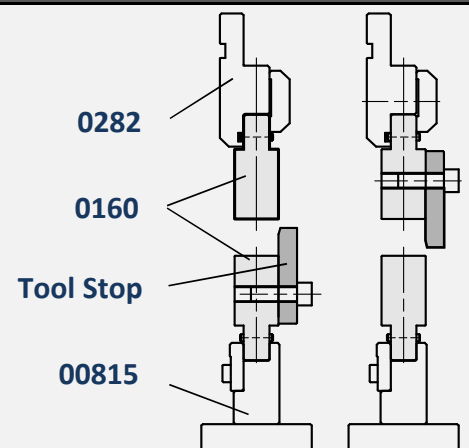

Staged Offset Tool Z3
Staged Offset Tool Z4
Staged Offset Tool Z5

1000 kN/m

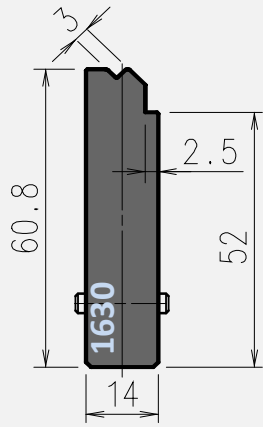

Tool 1630 replaces old tool SZ03

Length mm	Item No.	Weight Kg
835	ED 1630061	5,4
415	ED 1630062	2,7
800 sect.	ED 1630063	5,2

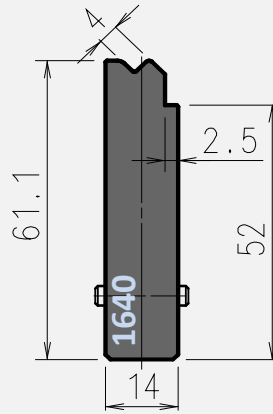

Tool 1640 replaces old tool SZ04

Item No.	Weight Kg
ED 1640081	5,4
ED 1640082	2,7
ED 1640083	5,2

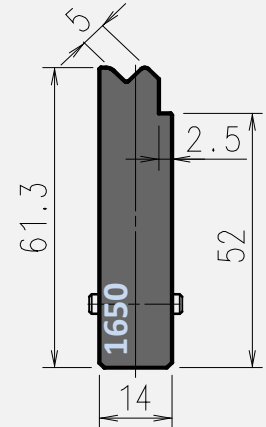

Tool 1650 replaces old tool SZ05

Item No.	Weight Kg
ED 1650101	5,4
ED 1650102	2,7
ED 1650103	5,2

Staged Offset Tool Z6
Staged Offset Tool Z8
Staged Offset Tool Z10

1000 kN/m

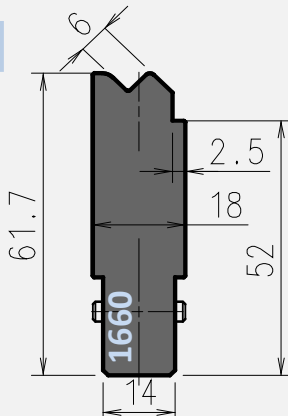

Tool 1660 replaces old tool SZ06

Length mm	Item No.	Weight Kg
835	ED 1660101	6,4
415	ED 1660102	3,2
800 sect.	ED 1660103	6,1

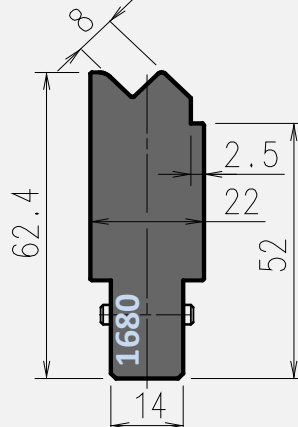

Tool 1680 replaces old tool SZ08

Item No.	Weight Kg
ED 1680101	7,5
ED 1680102	3,7
ED 1680103	7,2

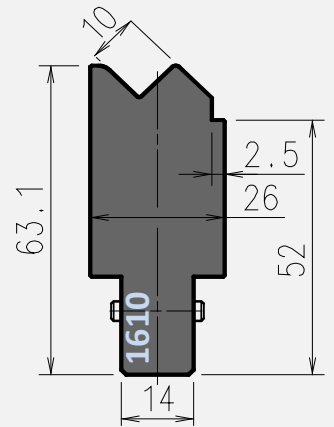

Tool 1610 replaces old tool SZ10

Item No.	Weight Kg
ED 1610101	8,6
ED 1610102	4,3
ED 1610103	8,2

Note:

- Staged offset tools are reversible and can be mounted on a punch or die holder
- Use with holder 0282 for H=90mm and with 0582 for H=120mm punch height
- Two of each code are required when ordering a punch and die set

As top tool

As bottom tool

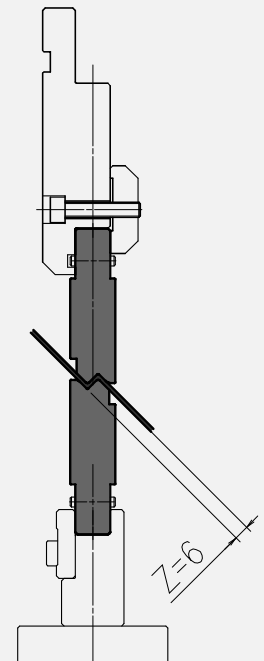
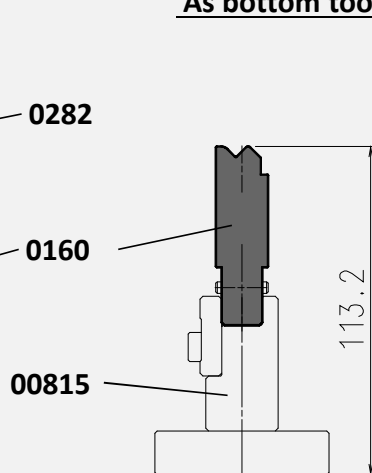
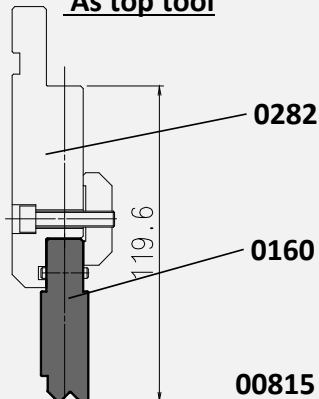

90° 2V dies (V4 to V9)

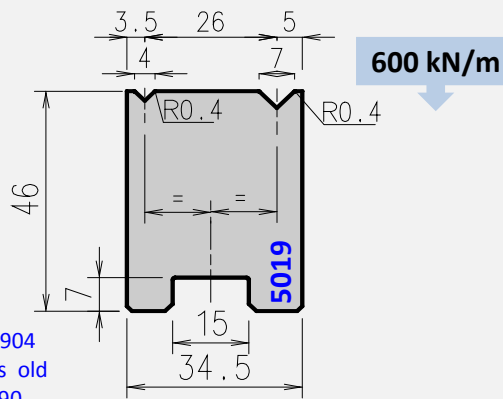

Die 501904 replaces old die 50190

Tool angle	Length mm	Item No.	Weight Kg
90°	835	ED 5019041	9,6
	415	ED 5019042	4,8
	800 sect.	ED 5019043	9,2

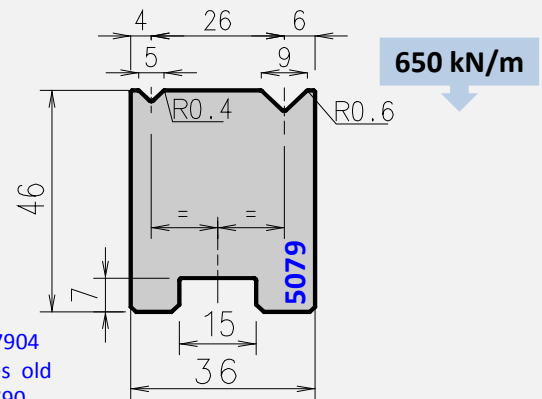

Die 507904 replaces old die 50790

Tool angle	Length mm	Item No.	Weight Kg
90°	835	ED 5079041	10,0
	415	ED 5079042	5,0
	800 sect.	ED 5079043	9,6

90° 2V dies (V6 to V12)

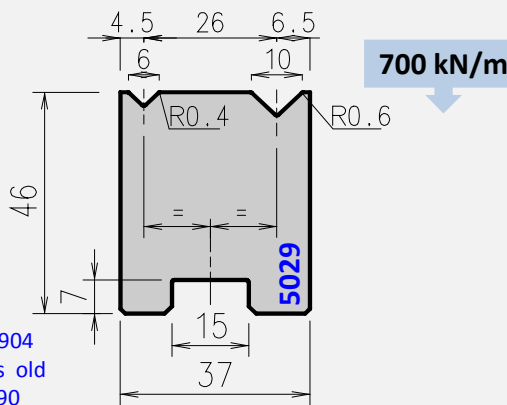

Die 502904 replaces old die 50290

Tool angle	Length mm	Item No.	Weight Kg
90°	835	ED 5029041	10,3
	415	ED 5029042	5,1
	800 sect.	ED 5029043	9,9

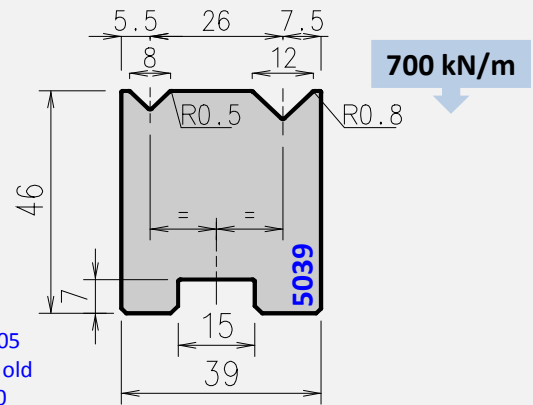

Die 503905 replaces old die 50390

Tool angle	Length mm	Item No.	Weight Kg
90°	835	ED 5039051	10,7
	415	ED 5039052	5,3
	800 sect.	ED 5039053	10,3

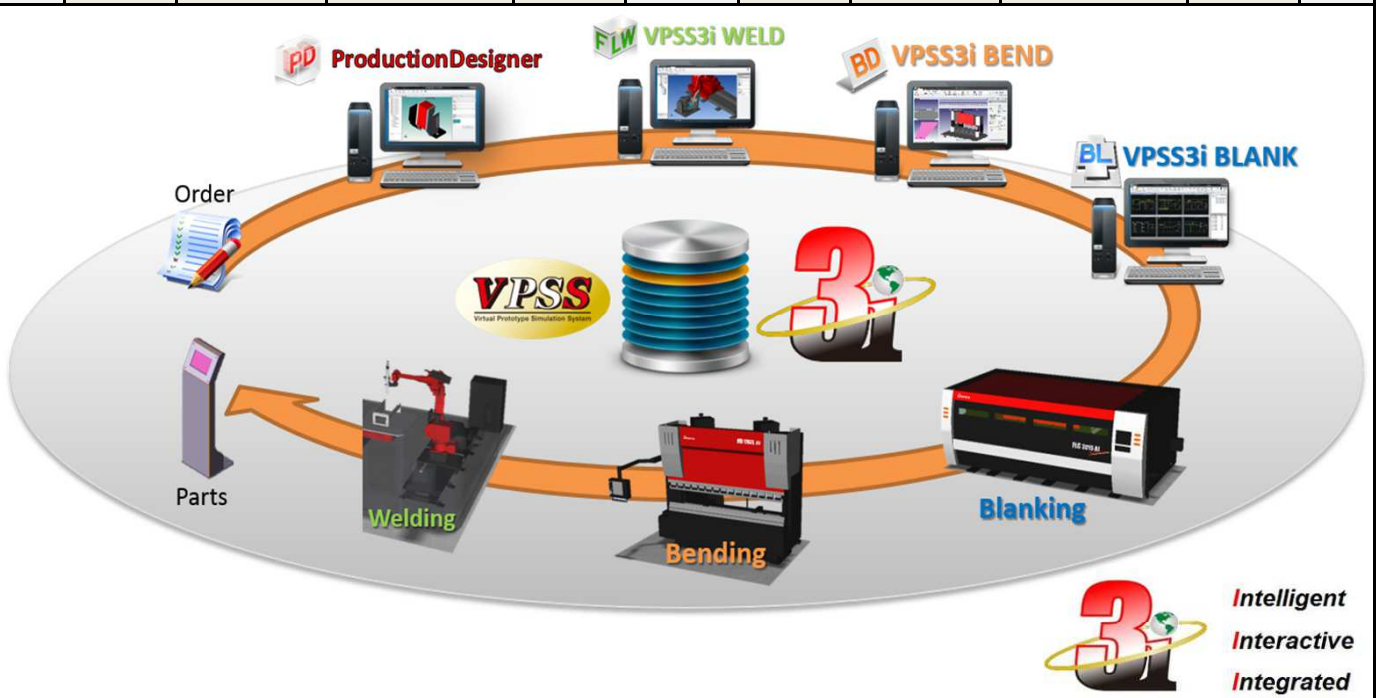

88° 2V dies (V4 to V10)

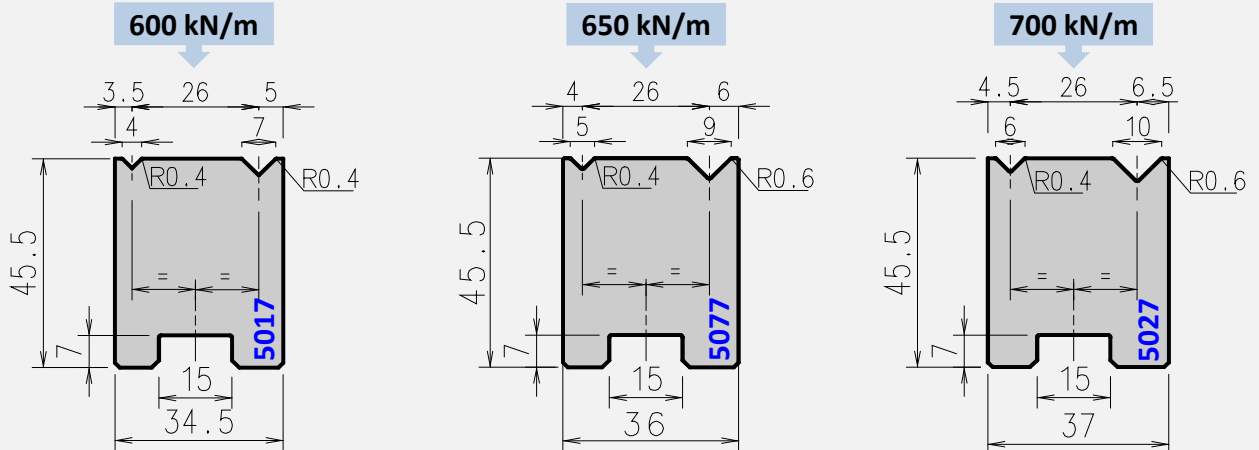

Die 501704 replaces old die 50196

Die 507704 replaces old die 50796

Die 502704 replaces old die 50296

Tool angle	Length mm	Item No.	Weight Kg
88°	835	ED 5017041	9,5
	415	ED 5017042	4,7
	800 sect.	ED 5017043	9,1

Item No.	Weight Kg
ED 5077041	9,9
ED 5077042	4,9
ED 5077043	9,5

Item No.	Weight Kg
ED 5027041	10,2
ED 5027042	5,1
ED 5027043	9,8

88° 2V dies (V8 to V20)

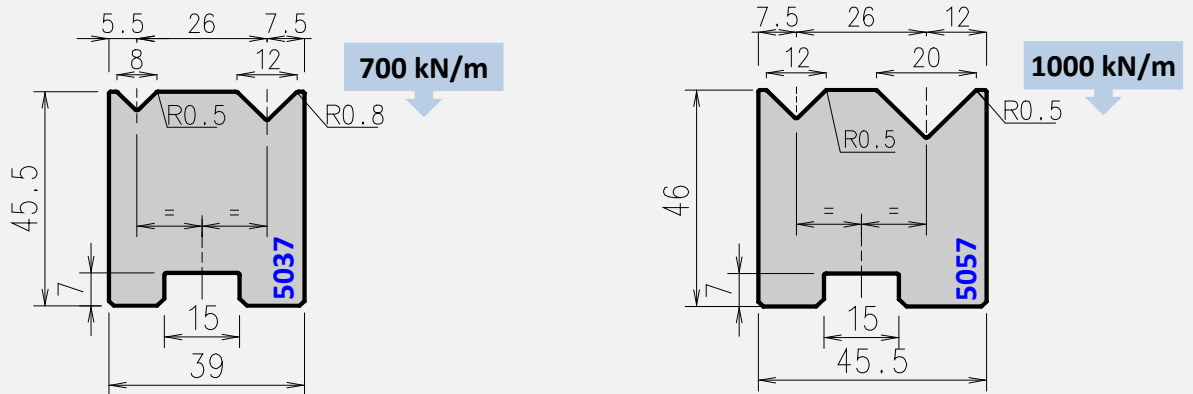

Die 503705 replaces old die 50396

Die 505705 replaces old die 50596

Tool angle	Length mm	Item No.	Weight Kg
88°	835	ED 5037051	10,6
	415	ED 5037052	5,3
	800 sect.	ED 5037053	10,2

Tool angle	Length mm	Item No.	Weight Kg
88°	835	ED 5057051	12,1
	415	ED 5057052	6,0
	800 sect.	ED 5057053	11,6

88° 2V dies (V14 to V25)

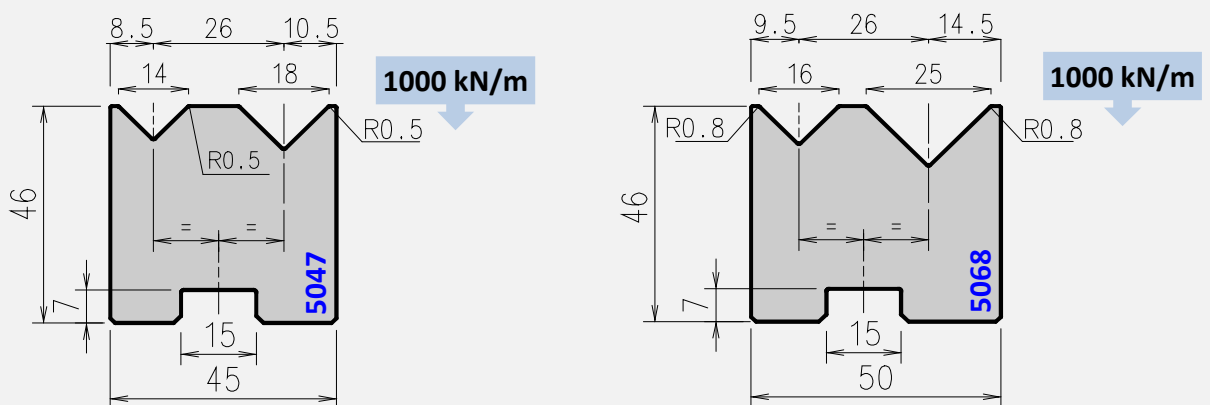

Die 504705 replaces old die 50496

Die 506708 replaces old die 50696

Tool angle	Length mm	Item No.	Weight Kg
88°	835	ED 5047051	12,0
	415	ED 5047052	6,0
	800 sect.	ED 5047053	11,5

Tool angle	Length mm	Item No.	Weight Kg
88°	835	ED 5067081	12,9
	415	ED 5067082	6,4
	800 sect.	ED 5067083	12,4

30° - 2V dies (V6 to V12)

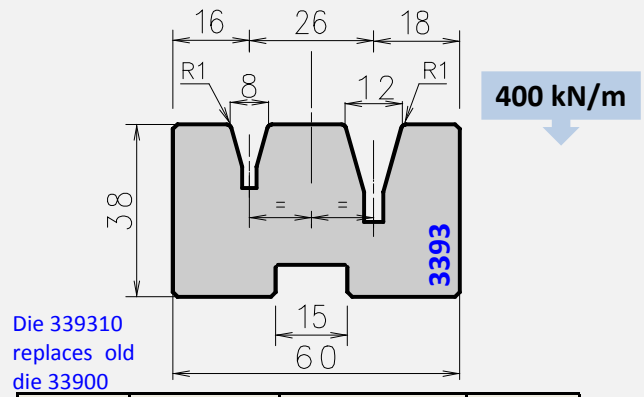
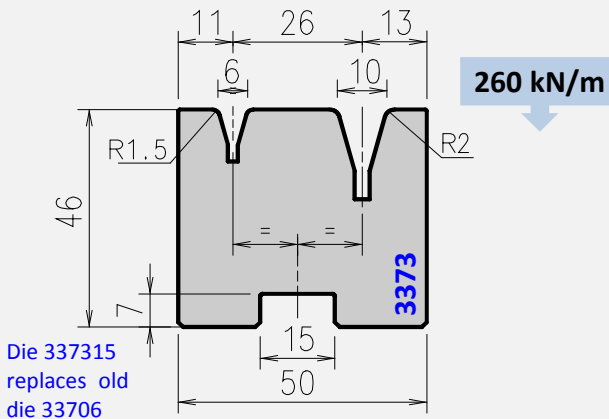

Tool angle	Length mm	Item No.	Weight Kg
30°	835	ED 3373151	13,5
	415	ED 3373152	6,7
	800 sect.	ED 3373153	12,9

Tool angle	Length mm	Item No.	Weight Kg
30°	835	ED 3393101	12,9
	415	ED 3393102	6,4
	800 sect.	ED 3393103	12,4

60° - 2V dies (V6 to V12)

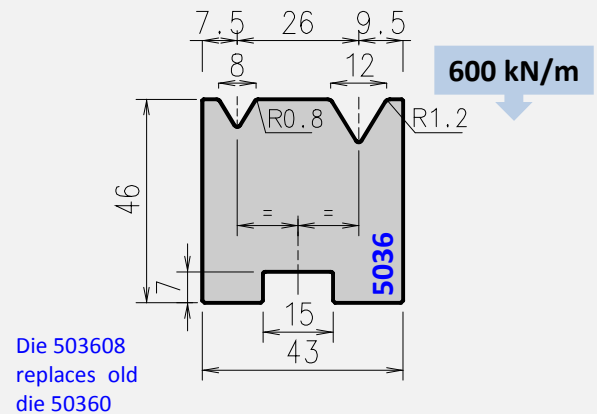
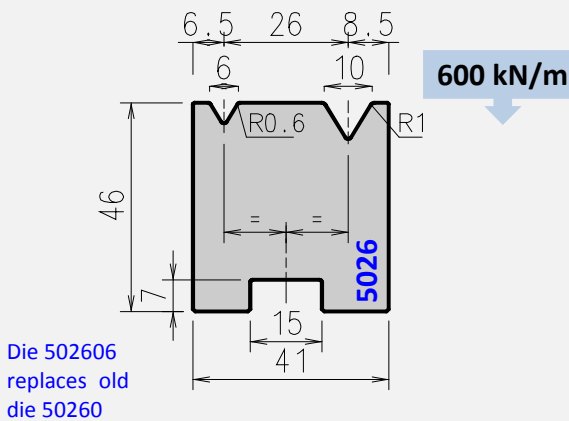

Tool angle	Length mm	Item No.	Weight Kg
60°	835	ED 5026061	11,3
	415	ED 5026062	5,6
	800 sect.	ED 5026063	10,8

Tool angle	Length mm	Item No.	Weight Kg
60°	835	ED 5036081	11,7
	415	ED 5036082	5,8
	800 sect.	ED 5036083	11,2

60° - 2V dies (V16 to V25)

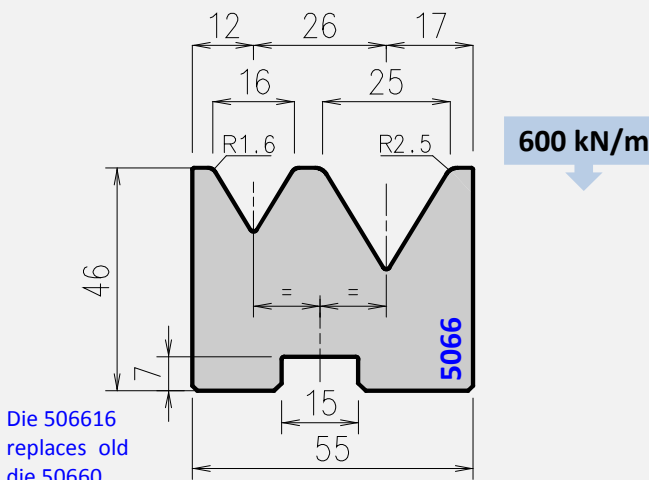

Tool angle	Length mm	Item No.	Weight Kg
60°	835	ED 5066161	13,4
	415	ED 5066162	6,7
	800 sect.	ED 5066163	12,8

V18 and V25 - 30° Large V dies

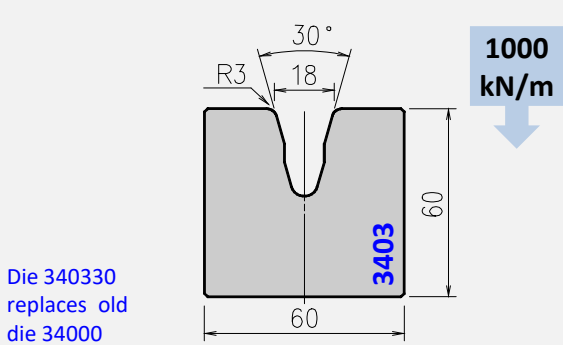

Tool angle	Length mm	Item No.	Weight Kg
30°	835	ED 3403301	21,4
	415	ED 3403302	10,6
	800 sect.	ED 3403303	20,5

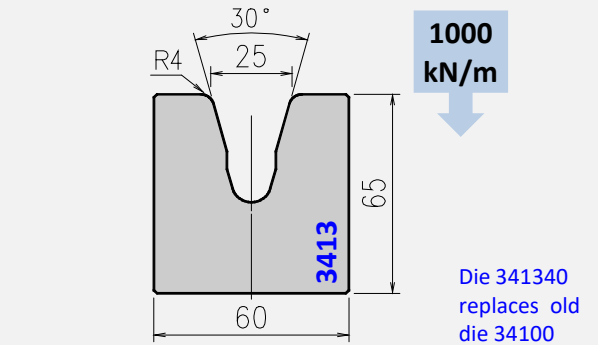

Tool angle	Length mm	Item No.	Weight Kg
30°	835	ED 3413401	21,7
	415	ED 3413402	10,8
	800 sect.	ED 3413403	20,8

V32 and V40 - 45° Large V dies

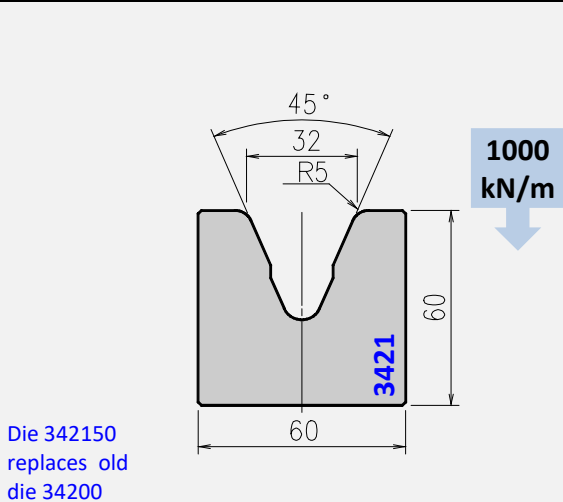

Tool angle	Length mm	Item No.	Weight Kg
45°	835	ED 3421501	19,3
	415	ED 3421502	9,6
	800 sect.	ED 3421503	18,5

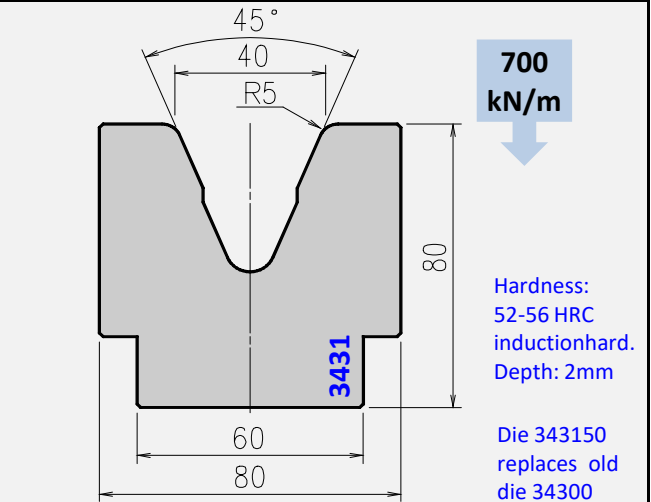

Tool angle	Length mm	Item No.	Weight Kg
45°	835	ED 3431501	32,6
	415	ED 3431502	16,2
	800 sect.	ED 3431503	31,2

V63 and V80 - 60° Large V dies

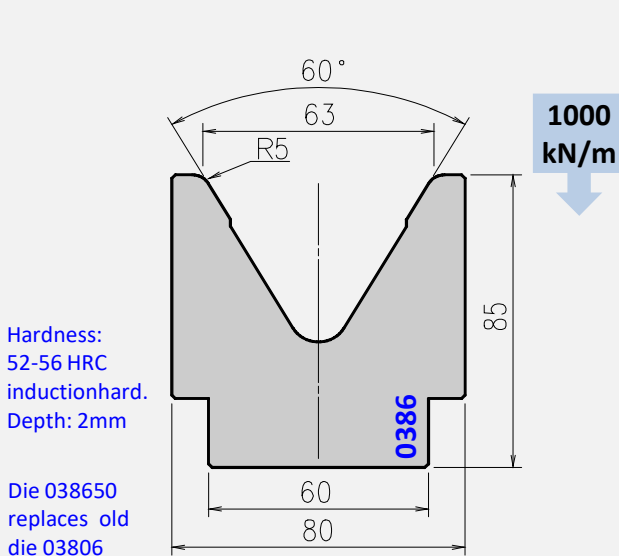

Tool angle	Length mm	Item No.	Weight Kg
60°	835	ED 0386501	30,2
	415	ED 0386502	15,0

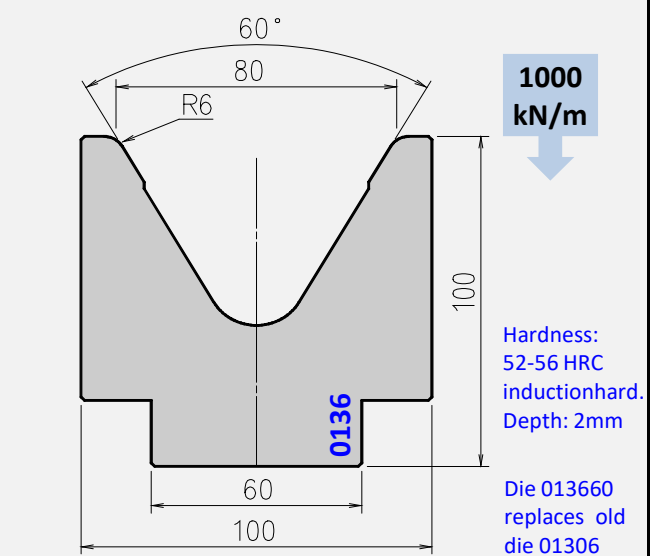

Tool angle	Length mm	Item No.	Weight Kg
60°	835	ED 0136601	42,0
	415	ED 0136602	20,9

V32 and V40 - 85° Large V dies

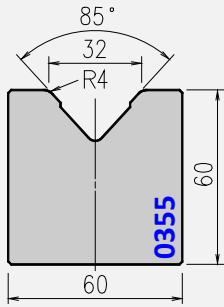

1000 kN/m

Die 035540
replaces old
die 03500

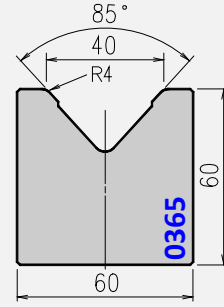

1000 kN/m

Die 036540
replaces old
die 03600

Tool angle	Length mm	Item No.	Weight Kg
85°	835	ED 0355401	21,4
	415	ED 0355402	10,7
	800 sect.	ED 0355403	20,5

Tool angle	Length mm	Item No.	Weight Kg
85°	835	ED 0365401	20,2
	415	ED 0365402	10,1
	800 sect.	ED 0365403	19,4

V50 and V63 - 85° Large V dies

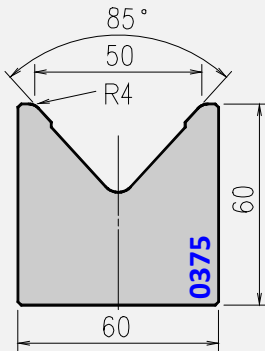

1000 kN/m

Die 037540
replaces old
die 03700

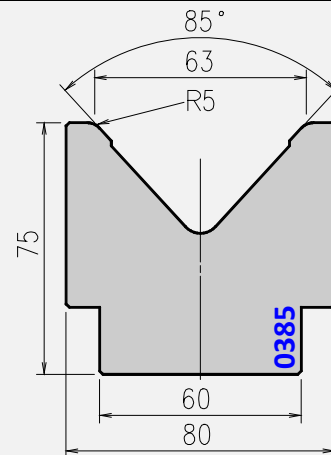

1000 kN/m

Hardness:
52-56 HRC
inductionhard.
Depth: 2mm

Die 038550
replaces old
dies 03800
and Z0063

Tool angle	Length mm	Item No.	Weight Kg
85°	835	ED 0375401	18,7
	415	ED 0375402	9,3
	800 sect.	ED 0375403	17,9

Tool angle	Length mm	Item No.	Weight Kg
85°	835	ED 0385501	29,1
	415	ED 0385502	14,4
	800 sect.	ED 0385503	27,8

V80 - 85° and V100 - 80° Large V dies

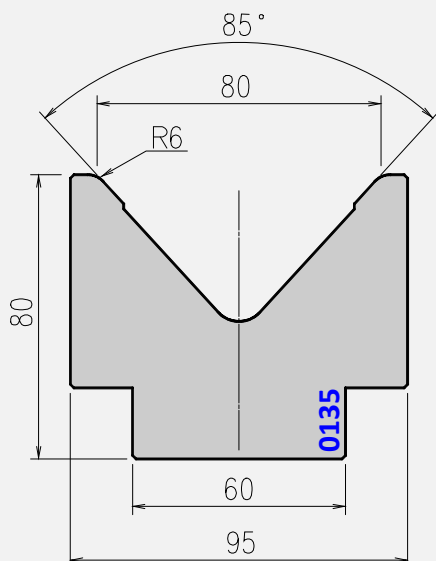

1000 kN/m

Hardness:
52-56 HRC
inductionhard.
Depth: 2mm

Die 013560
replaces old
die Z0080

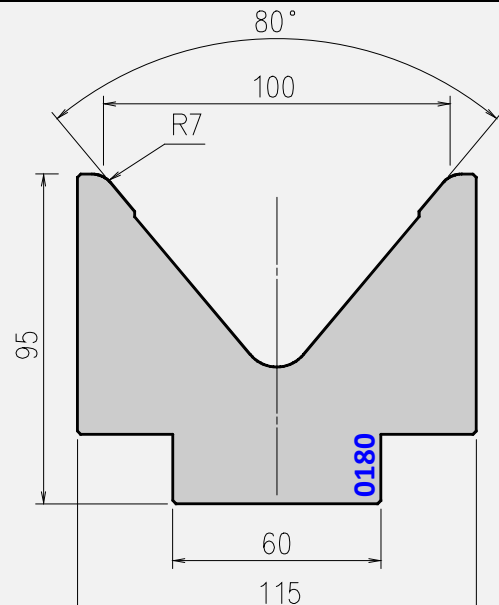

1000 kN/m

Hardness:
52-56 HRC
inductionhard.
Depth: 2mm

Die 018070
replaces old
die Z0100

Tool angle	Length mm	Item No.	Weight Kg
85°	835	ED 0135601	33,2
	415	ED 0135602	16,5

Tool angle	Length mm	Item No.	Weight Kg
80°	835	ED 0180701	44,1
	415	ED 0180702	21,9

V125 and V160 - 80° Large V dies

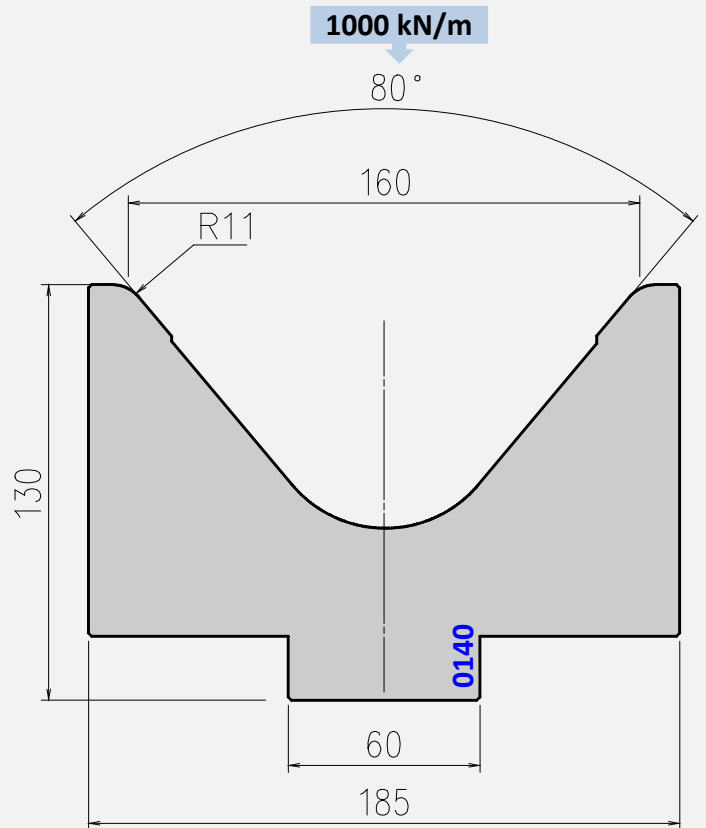
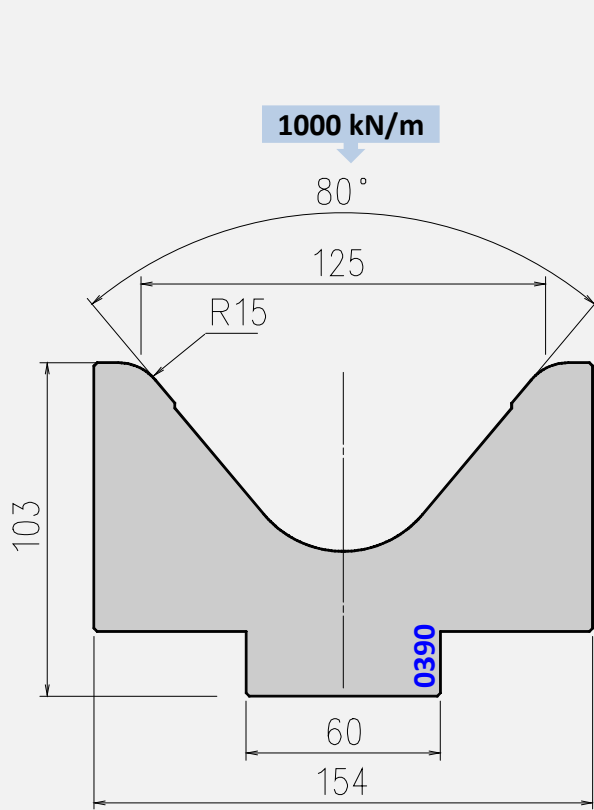

Hardness: 52-56 HRC; inductionhard.; Depth: 2mm
Die 039015 replaces old die Z0125

Tool angle	Length mm	Item No.	Weight Kg
80°	835	ED 0390151	62,0
	415	ED 0390152	30,8

Hardness: 52-56 HRC; inductionhard.; Depth: 2mm
Die 014011 replaces old die Z0160

Tool angle	Length mm	Item No.	Weight Kg
80°	835	ED 0140111	92,6
	415	ED 0140112	46,0

4V - 85° - 88°

4V - 60°

3U - 90°

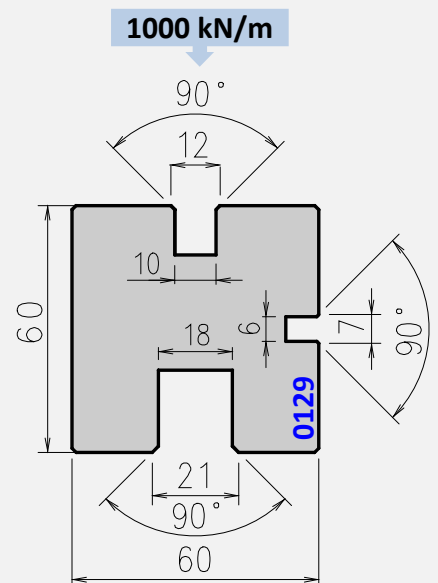
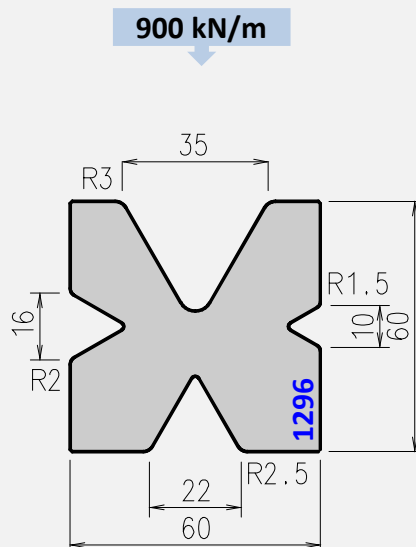
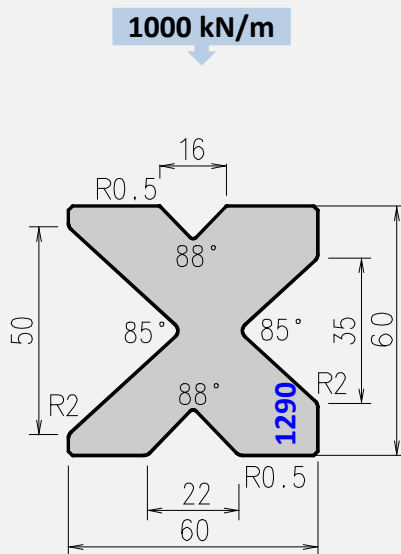

Hardness: 52-56 HRC; inductionhard.; Depth: 2mm
Die 129000 replaces old die Z0000

Length mm	Item No.	Weight Kg
835	ED 1290001	15,6
415	ED 1290002	7,8

Hardness: 52-56 HRC; inductionhard.; Depth: 2mm
Die 129600 replaces old die Z0006

Item No.	Weight Kg
ED 1296001	17,8
ED 1296002	8,8

Hardness: 28-32 HRC; Throughhardened;
Die 012900 replaces old die 01200

Item No.	Weight Kg
ED 0129001	20,2
ED 0129002	10,1

30° Hemming dies (V6 to V8)

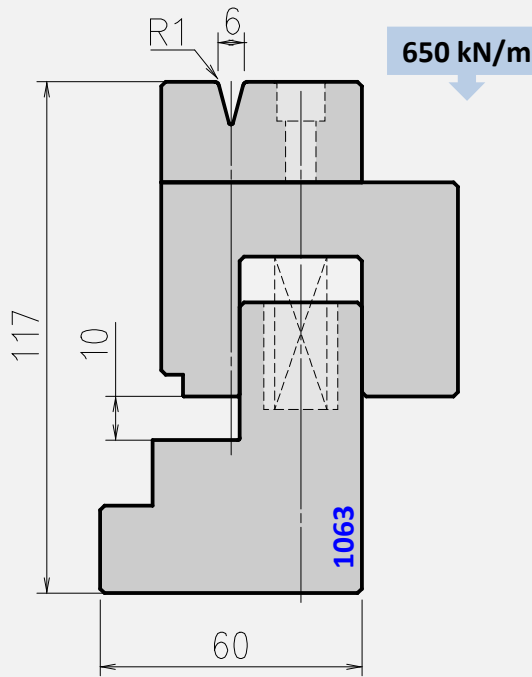

Die 106310 replaces old die 10469

Tool angle	Length mm	Item No.	Weight Kg
30°	835	ED 1063101	40,4
	415	ED 1063102	20,1

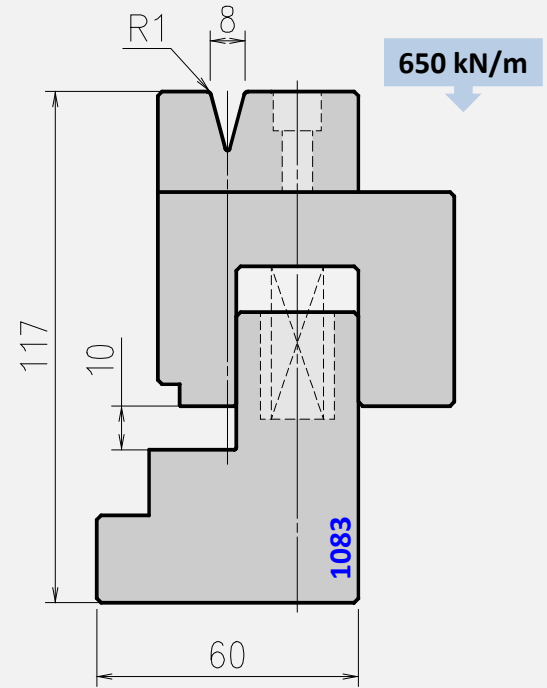

Die 108310 replaces old die 10409

Tool angle	Length mm	Item No.	Weight Kg
30°	835	ED 1083101	40,2
	415	ED 1083102	20,0

Replacement parts for 30° Hemming dies (V6 to V8)

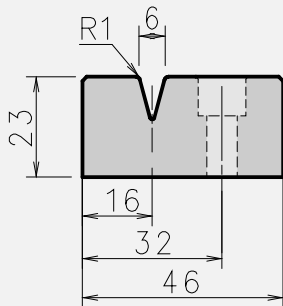

Die 006310 replaces old die 80149

Tool angle	Length mm	Item No.	Weight Kg
30°	835	ED 0063101	6,7
	415	ED 0063102	3,3

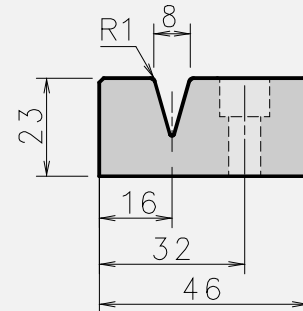

Die 008310 replaces old die 80139

Tool angle	Length mm	Item No.	Weight Kg
30°	835	ED 0083101	6,5
	415	ED 0083102	3,2

Tonnage required for hemming

Sheet thickness t mm	Mild steel (400 N/mm ²)			Stainless steel (600 N/mm ²)		
	Tonnage kN/m	C mm	Tonnage kN/m	Tonnage kN/m	C mm	Tonnage kN/m
0,60	230	3	90	350	3	150
0,80	320	3	120	500	3	200
1,00	400	3,5	150	600	3,5	250
1,25	500	3,5	170	800	3,5	260
1,50	630	4,6	220	950	4,6	380
2,00	800	5,5	300	1300	5,5	500
2,50	900	6,5	550	1800	6,5	900
3,00	1000	8	700	2100	8	1000

26° Hemming dies (V10 to V12)

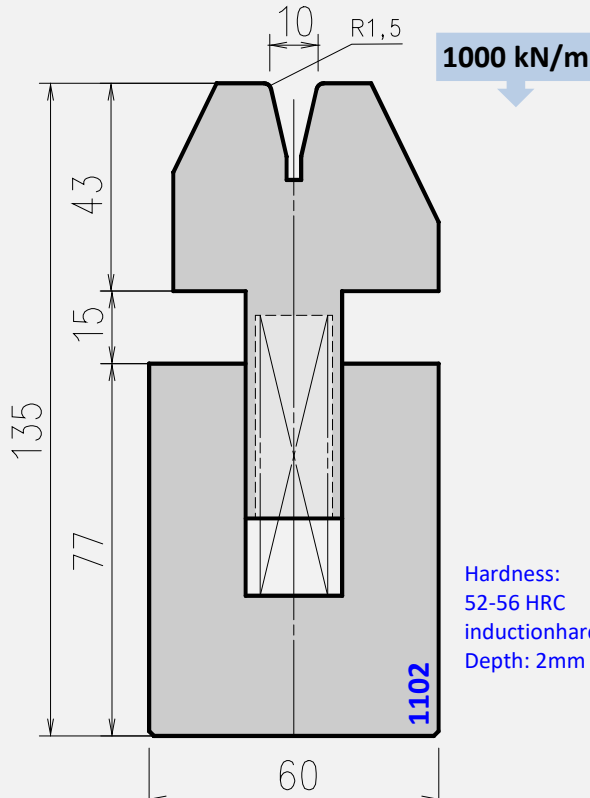

Hardness:
52-56 HRC
inductionhard.
Depth: 2mm

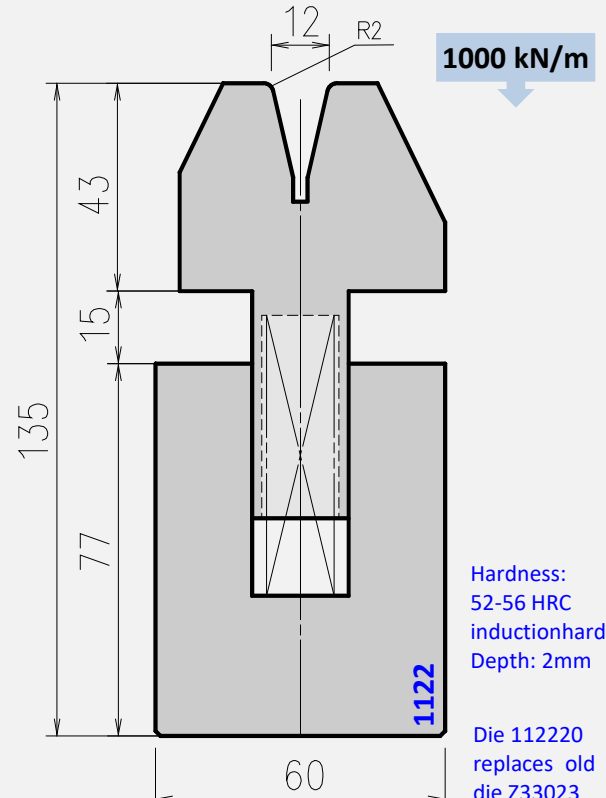

Hardness:
52-56 HRC
inductionhard.
Depth: 2mm

Die 112220
replaces old
die Z33023

Tool angle	Length mm	Item No.	Weight Kg
26°	835	ED 1102151	42,5
	415	ED 1102152	21,1

Tool angle	Length mm	Item No.	Weight Kg
26°	835	ED 1122201	42,1
	415	ED 1122202	20,9

30° Hemming insert dies (V6 to V8)

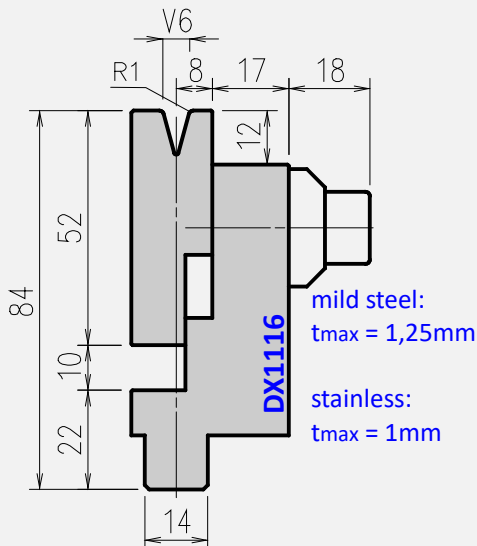

mild steel:
t_{max} = 1,25mm

stainless:
t_{max} = 1mm

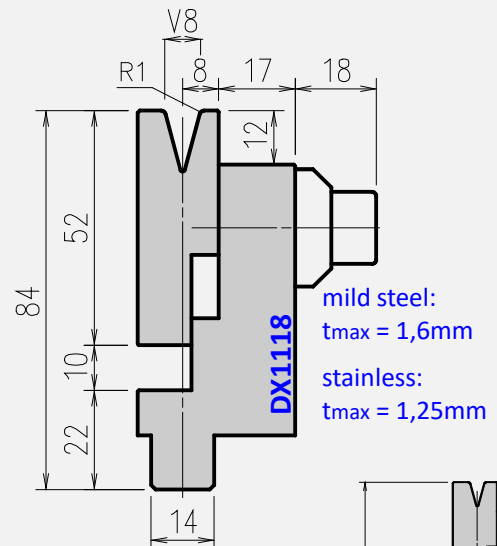

mild steel:
t_{max} = 1,6mm

stainless:
t_{max} = 1,25mm

Note:

- Tonnage for 30° prebending : 500 kN/m
- Tonnage for flattening 800 kN/m
- 470 Sect. = 45 + 2x50 + 55 + 60 + 65 + 70 + 75
- tool hardness HRC 36 to 42

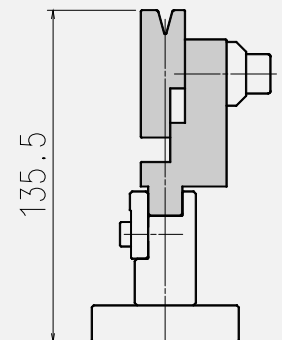

Tool angle	Length mm	Item No.	Weight Kg
30°	835	DX 111601	16,0
	415	DX 111602	8,0
	470 Sect.	DX 111681	9,0

Tool angle	Length mm	Item No.	Weight Kg
30°	835	DX 111801	16,0
	415	DX 111802	8,0
	470 Sect.	DX 111881	9,0

Pneumatic die holder (for standard and hemming bends)

The **pneumatic die holder** is a permanent fixture on the press brake machine and operates as:

- traditional die holder with standard (or special) dies for 90° or acute bends
- double decker hemming system with acute-angle dies. The pneumatic movement is considered as a programmable NC axis in the control system and ensures a rapid opening or closing.

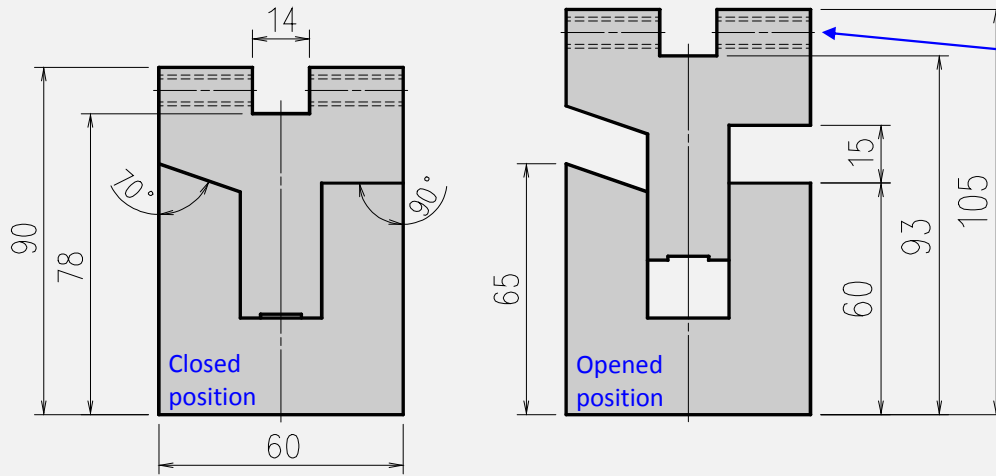

screw holes for mounting the optional clamps (during the use with large V dies)

Length mm	Item No.	Weight Kg
1250	T04066AN	50
2050	T04067AN	82
2550	T04068AN	102
3050	T04069AN	122
4050	T04070AN	162

Note:

- tonnage in closed position: up to 1000 kN/m, depends on die
- tonnage in opened position: up to 600 kN/m, depends on die
- die holder with induction hardened working surfaces (54-58 HRC)
- included accessories:
 - air distribution and regulation assy
 - relays 12V DC and 24V DC (according to your press brake)
 - air pipes and electric cables
 - temporary plates for easy installation
- please read operator's manual before installation

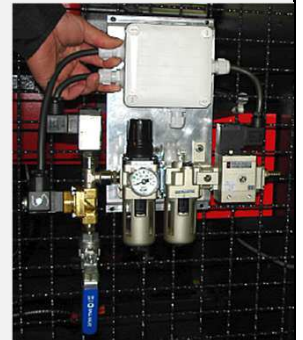

Optional clamps (with mounting hardware) for large V dies:

- for front side : T50001A and for rear side : T50002A
- please choose clamp quantity from the below table

For length	Front side	Rear side
1250 mm	6	6
2050 mm	10	10
2550 mm	13	13
3050 mm	15	15
4050 mm	20	20

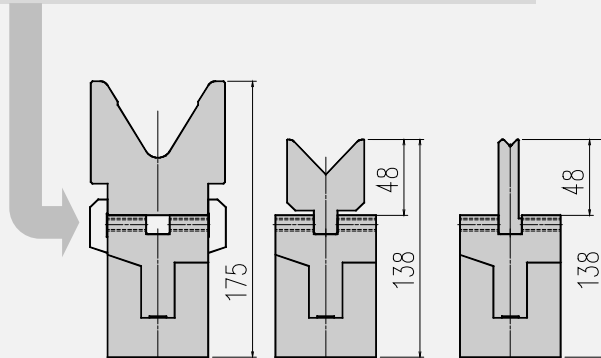

Use for standard bends: closed position

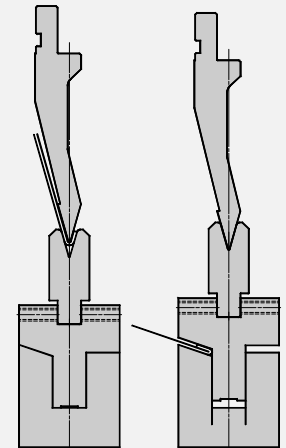

Use for hemming: closed and opened position



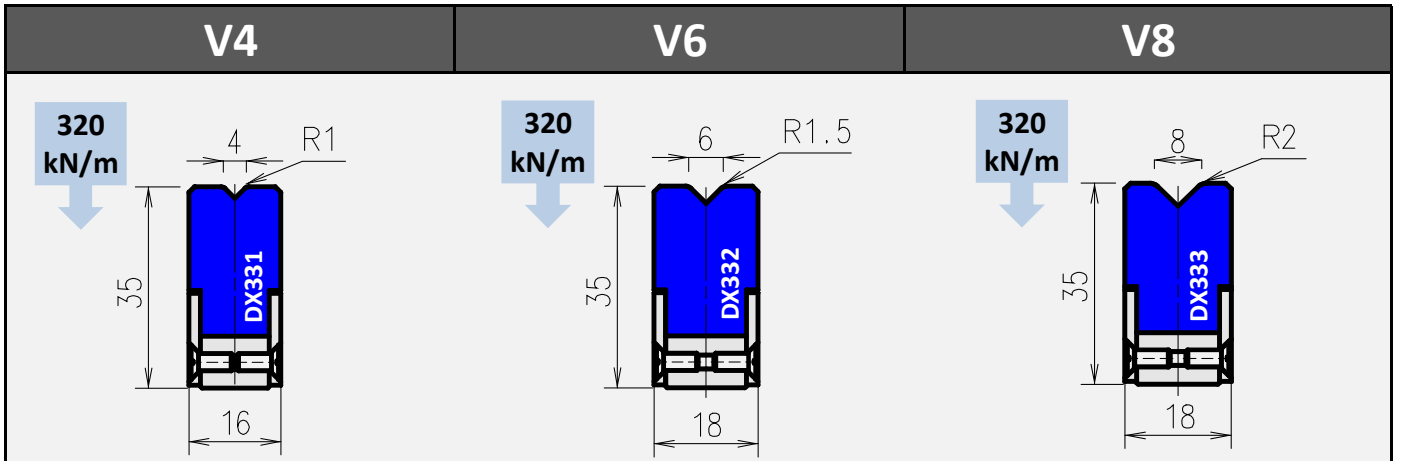

Tool angle	L mm	Item No.	Weight Kg	Tool angle	L mm	Item No.	Weight Kg	Tool angle	L mm	Item No.	Weight Kg
90°	835	DX 331001	1,2	90°	835	DX 332001	1,4	88°	835	DX 333001	1,4
	415	DX 331002	0,6		415	DX 332002	0,7		415	DX 333002	0,7

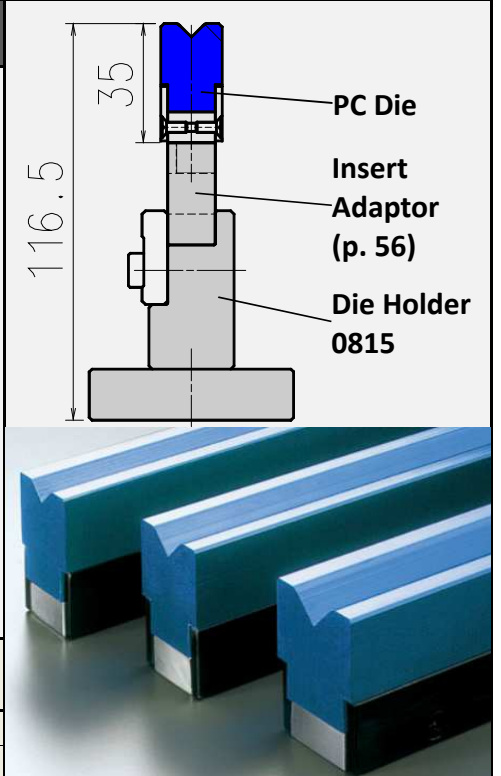
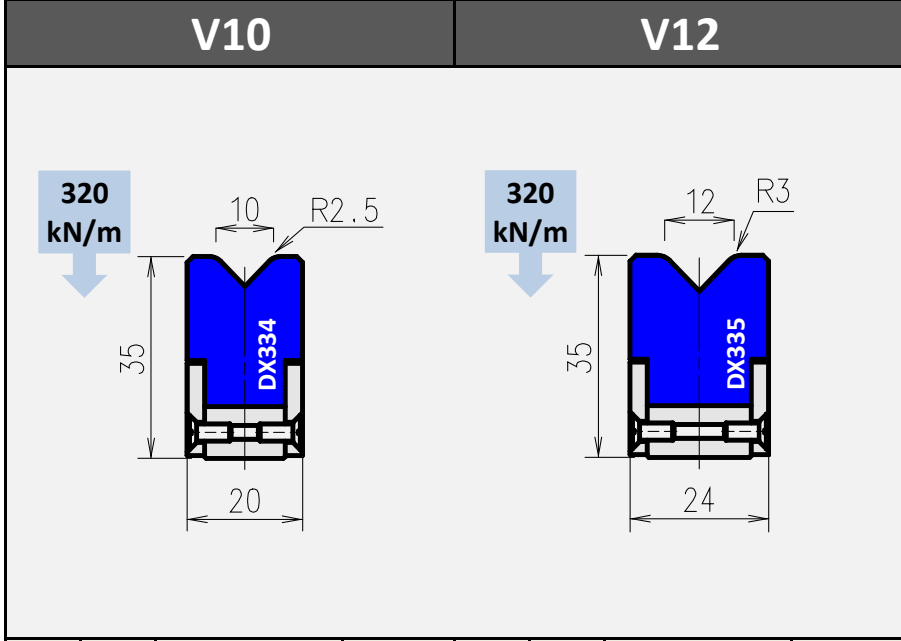

Tool angle	L mm	Item No.	Weight Kg	Tool angle	L mm	Item No.	Weight Kg
88°	835	DX 334001	1,6	88°	835	DX 335001	2,0
	415	DX 334002	0,8		415	DX 335002	1,0

V32				V40				V50			
-----	--	--	--	-----	--	--	--	-----	--	--	--

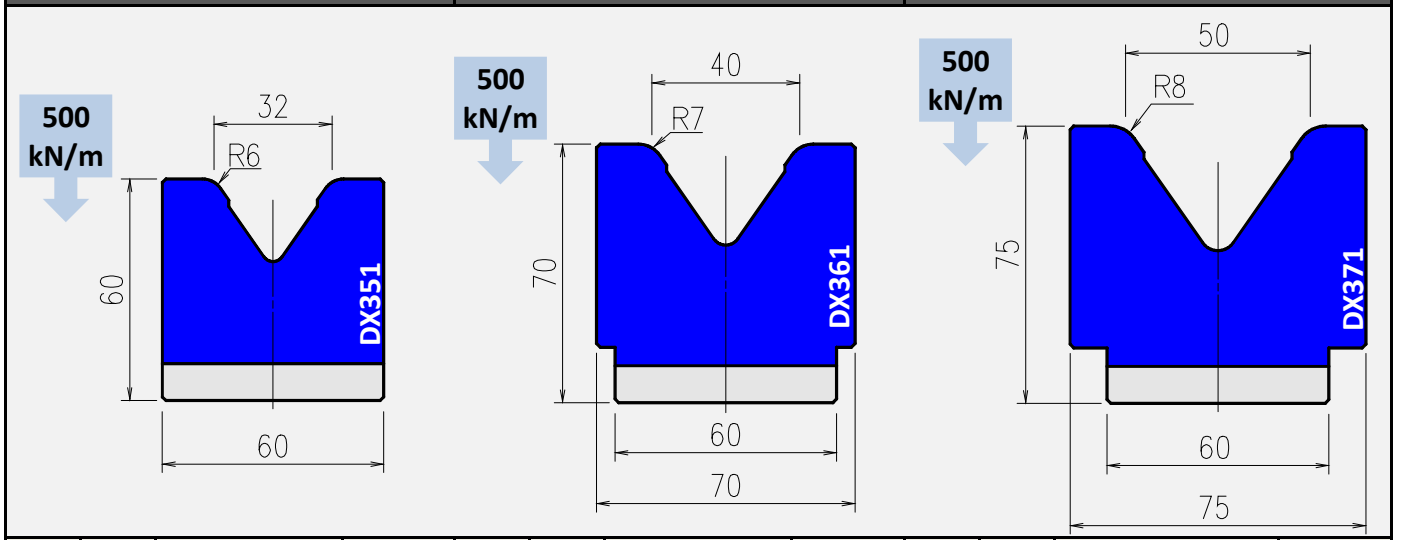

Tool angle	L mm	Item No.	Weight Kg	Tool angle	L mm	Item No.	Weight Kg	Tool angle	L mm	Item No.	Weight Kg
70°	835	DX 351001	8,4	70°	835	DX 361001	9,2	70°	835	DX 371001	9,5
	415	DX 351002	4,2		415	DX 361002	4,6		415	DX 371002	4,7

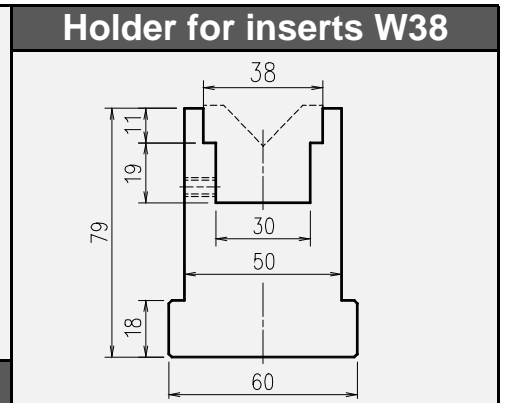
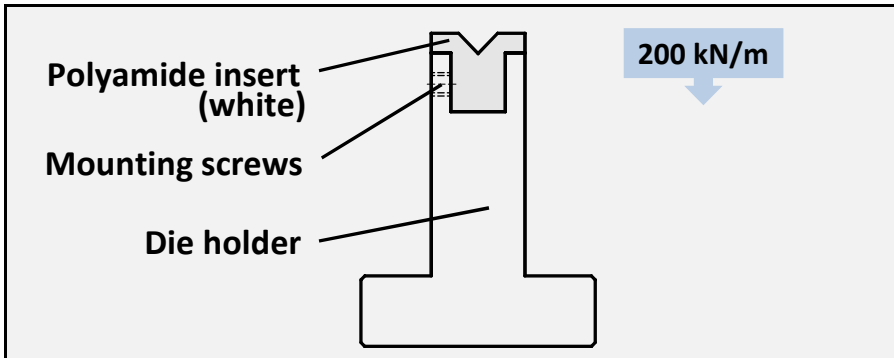

Holder for inserts W24

Holder for inserts W35

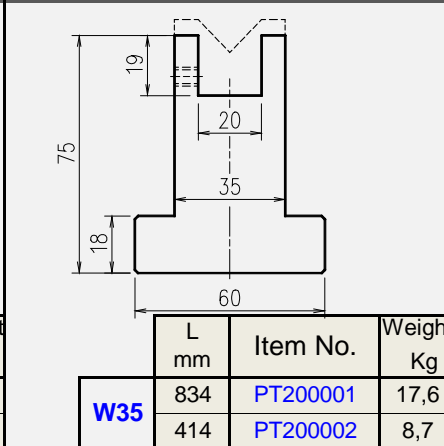
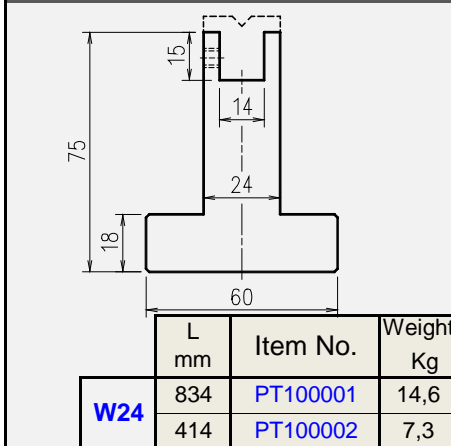

	L mm	Item No.	Weight Kg
W38	834	PT300001	20,5
	414	PT300002	10,2

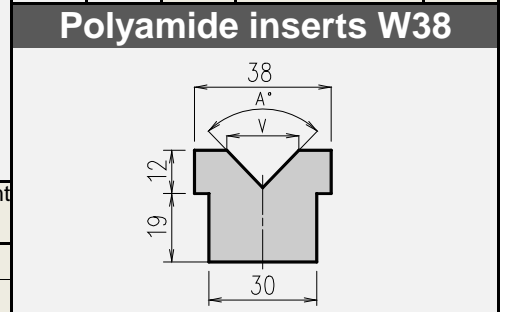

Polyamide inserts W24

Polyamide inserts W35

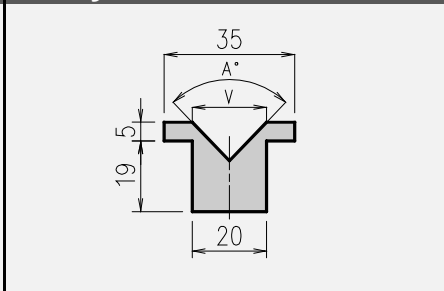
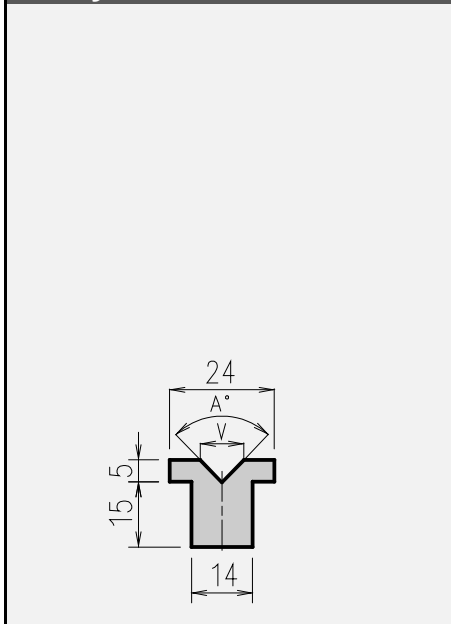

A°	V	L mm	Item No.	Weight Kg	
88°	6	835	PT306881	1,0	
		415	PT306882	0,5	
	8	835	PT308881	1,0	
		415	PT308882	0,5	
	10	835	PT310881	1,0	
		415	PT310882	0,5	
	12	835	PT312881	0,9	
		415	PT312882	0,5	
	16	835	PT316881	1,0	
		415	PT316882	0,5	
	20	835	PT320881	0,9	
		415	PT320882	0,5	
25		835	PT325881	0,9	
		415	PT325882	0,5	
60°	6	835	PT306601	1,0	
		415	PT306602	0,5	
	8	835	PT308601	1,0	
		415	PT308602	0,5	
	10	835	PT310601	1,0	
		415	PT310602	0,5	
	12	835	PT312601	1,0	
		415	PT312602	0,5	
	16	835	PT316601	0,9	
		415	PT316602	0,5	
		20	835	PT320601	0,9
			415	PT320602	0,5
30°	6	835	PT306301	1,0	
		415	PT306302	0,5	
	8	835	PT308301	1,0	
		415	PT308302	0,5	
	10	835	PT310301	0,9	
		415	PT310302	0,5	
	12	835	PT312301	0,9	
		415	PT312302	0,5	
	16	835	PT316301	0,8	
		415	PT316302	0,4	

A°	V	L mm	Item No.	Weight Kg
88°	6	835	PT106881	0,3
		415	PT106882	0,2
	8	835	PT108881	0,3
		415	PT108882	0,2
	10	835	PT110881	0,3
		415	PT110882	0,2
60°	6	835	PT106601	0,3
		415	PT106602	0,2
	8	835	PT108601	0,3
		415	PT108602	0,2
	10	835	PT110601	0,3
		415	PT110602	0,2
30°	6	835	PT106301	0,3
		415	PT106302	0,2
	8	835	PT108301	0,3
		415	PT108302	0,2
	10	835	PT110301	0,3
		415	PT110302	0,2

Pad Holder 25

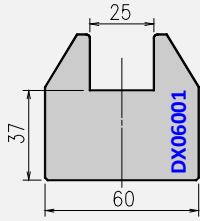

L mm	Item No.	Weight Kg
835	DX 060011	21
415	DX 060012	10,5

Urethane Pad 25

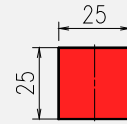

	L mm	Item No.	Weight Kg
Red	835	DX 061111	1
	415	DX 061112	0,5
Blue	835	DX 061121	1
	415	DX 061122	0,5

Pad Holder 30

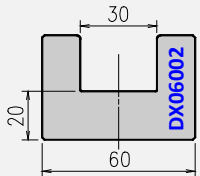

L mm	Item No.	Weight Kg
835	DX 060021	15
415	DX 060022	7,5

Urethane Pad 30

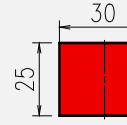

	L mm	Item No.	Weight Kg
Red	835	DX 061211	1
	415	DX 061212	0,5
Blue	835	DX 061221	1
	415	DX 061222	0,5

Pad Holder 50

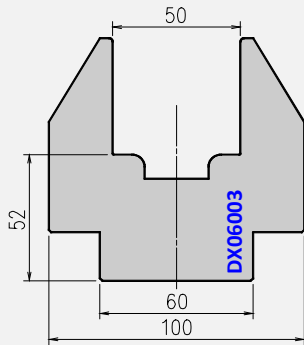

L mm	Item No.	Weight Kg
835	DX 060031	45
415	DX 060032	22,5

Urethane Pad 50

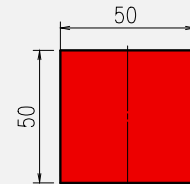

	L mm	Item No.	Weight Kg
Red	835	DX 061311	3
	415	DX 061312	1,5
Blue	835	DX 061321	3
	415	DX 061322	1,5

Pad Holder 80

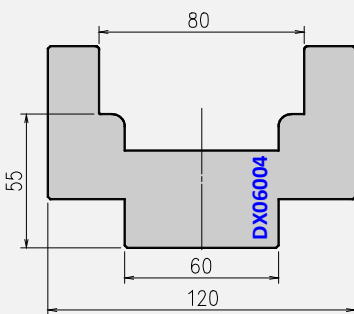

L mm	Item No.	Weight Kg
835	DX 060041	55
415	DX 060042	27,5

Urethane Pad 80

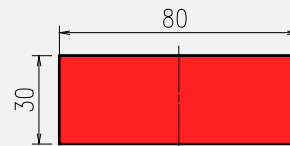

	L mm	Item No.	Weight Kg
Red	835	DX 061411	3
	415	DX 061412	1,5
Blue	835	DX 061421	3
	415	DX 061422	1,5

Pad Holder 110

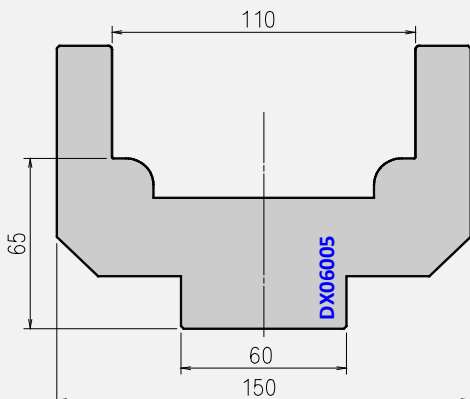

L mm	Item No.	Weight Kg
835	DX 060051	62
415	DX 060052	31

Urethane Pad 110

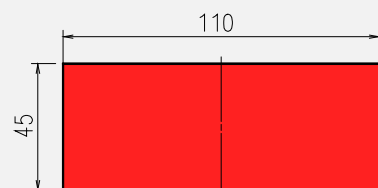

	L mm	Item No.	Weight Kg
Red	835	DX 061511	5
	415	DX 061512	2,5
Blue	835	DX 061521	5
	415	DX 061522	2,5

Urethane Sheet (RED)

0,3mm x 150mm

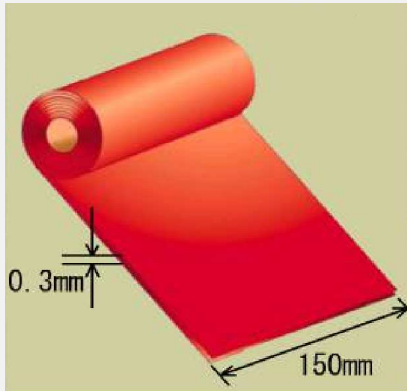

Item No.	L m
AC 426201	-

0,5mm x 150mm

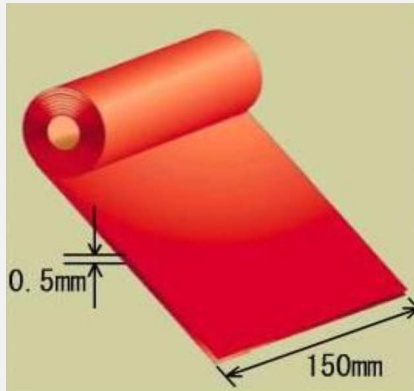

Item No.	L m
AC 426191	-

1 mm x 150mm

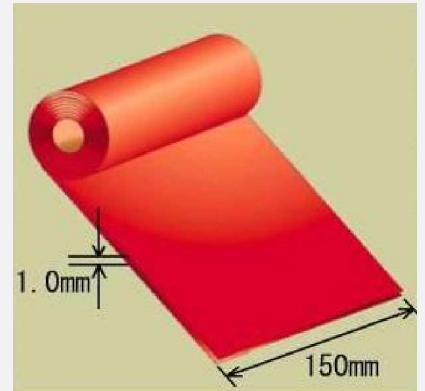

Item No.	L m
AC 426181	-

Note: Please provide required length when ordering

Adhesive Strip (WHITE 0,3 mm)

Item No.	L m
AC 909910	10

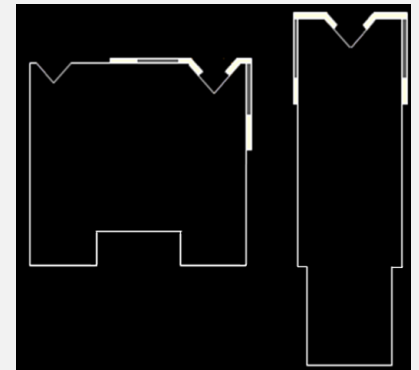
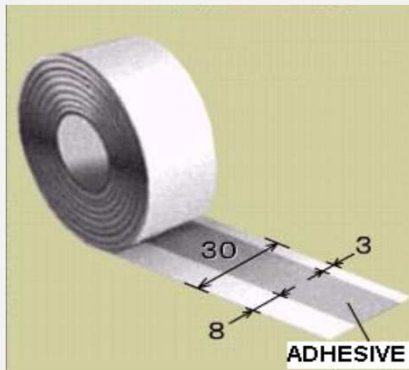

Urethane Cap (YELLOW 0,5 mm)

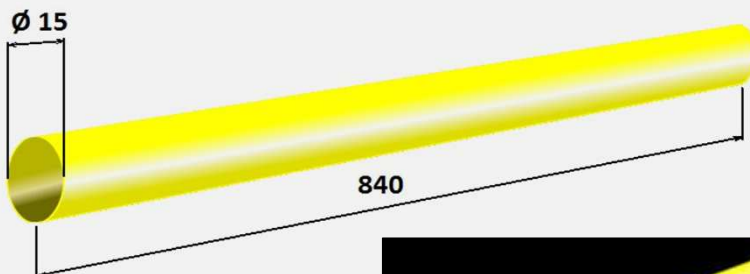

Item No.	Length
AC 909930	840mm x 5 off as set

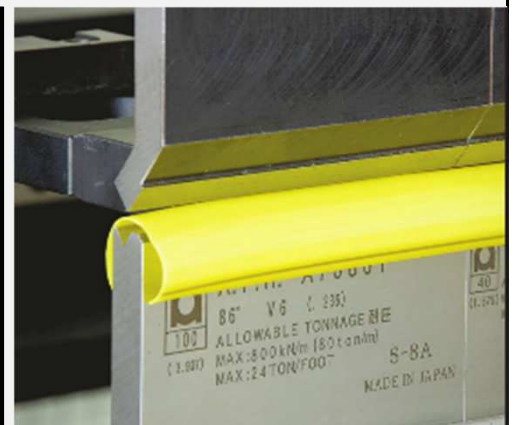
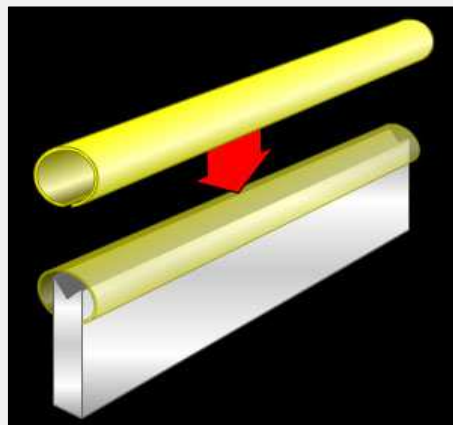

Die Holder 0815

Holder 0815 replaces old holders 80 and 815

Length mm	Item No.	Weight Kg
L=840mm	EH 0815001	12,4
S=420mm	EH 0815002	6,2

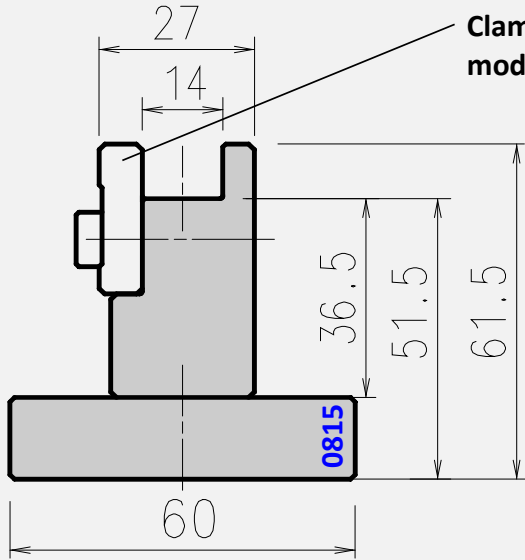

Clamp piece usable for insert mode and for clamp mode

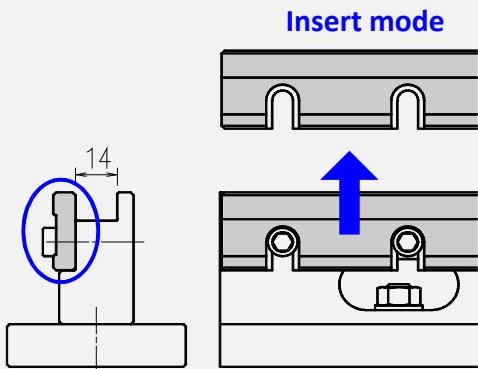
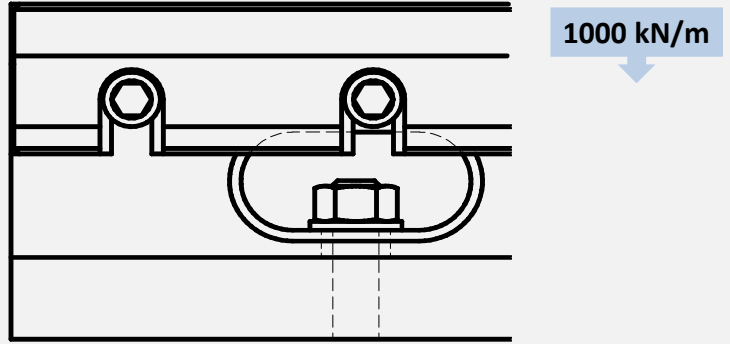

Turn 180°

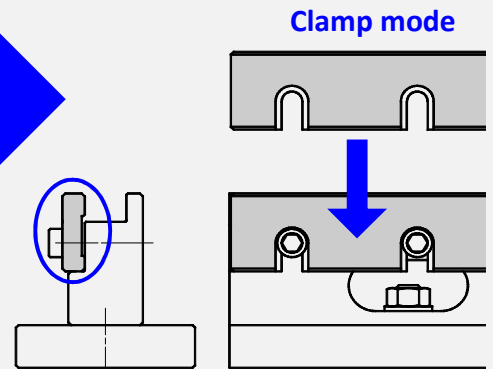

ED 0743251

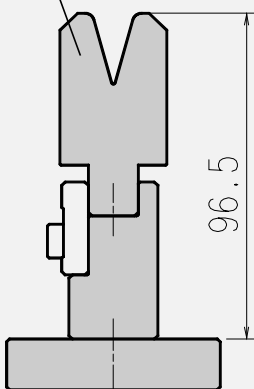

Die Holder FEAT

Length mm	Item No.	Weight Kg
L=850mm	DX 082501	13,5
S=510mm	DX 082502	8,0

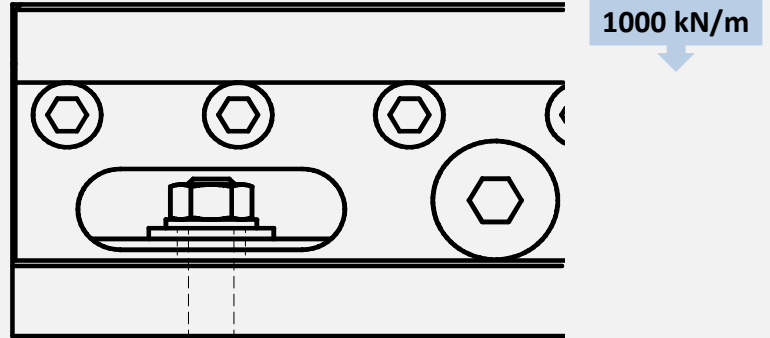
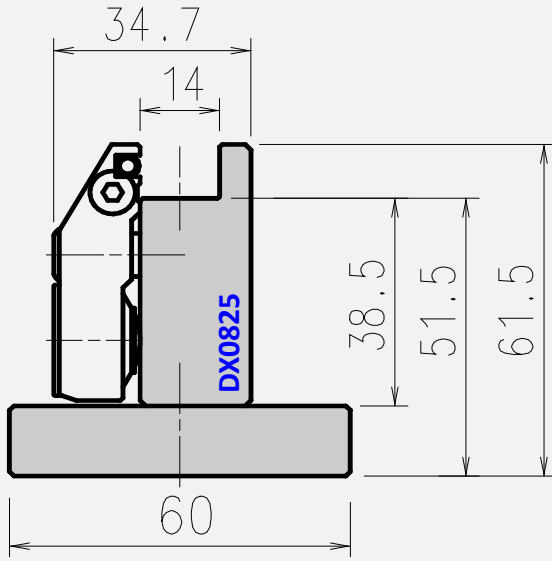

Die are clamped by rotating 5 bolts by 180°.



Clamping check for security: An indicator (red circle) appears in unclamping state. (2 indicators per clamp plate)

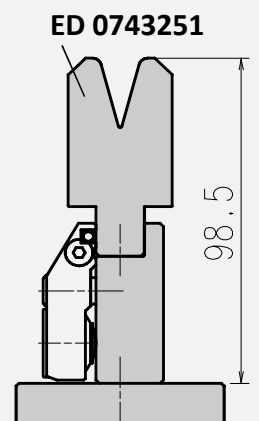
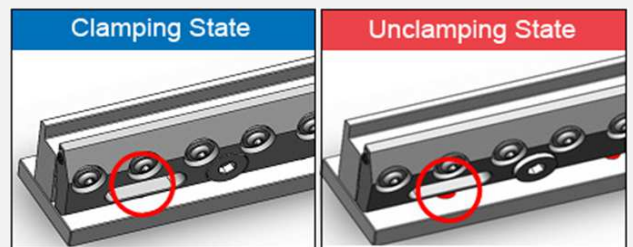

Die Holder 5340

Holder 5340 replaces old holder 534

Length mm	Item No.	Weight Kg
L=1050mm	EH 5340001	18,8
S=450mm	EH 5340002	8,0

All mounting hardware is included.

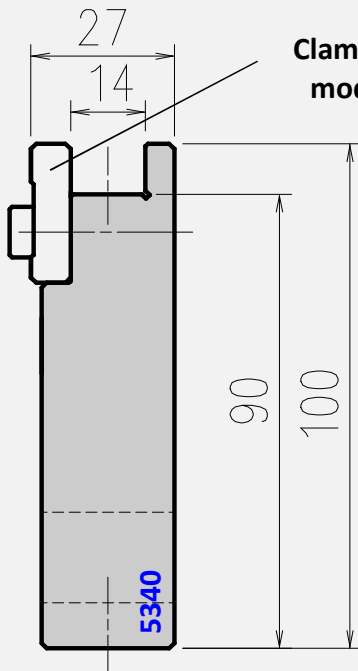

Clamp piece usable for insert mode and for clamp mode

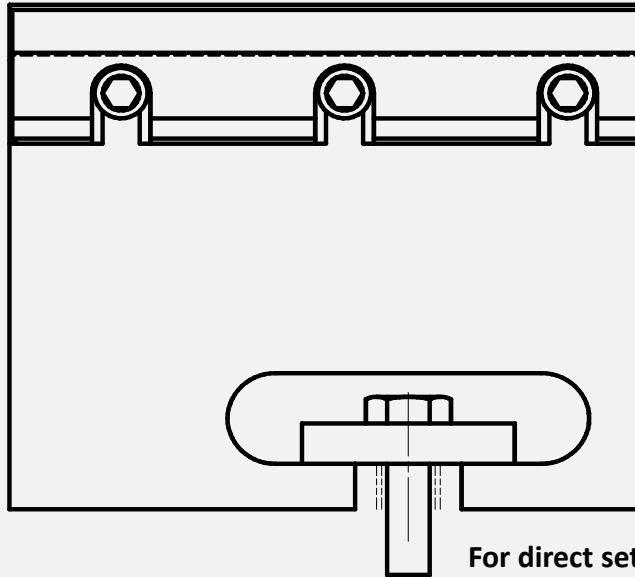

1000 kN/m

For direct setup on lower beam



Support for Die Holder 5340

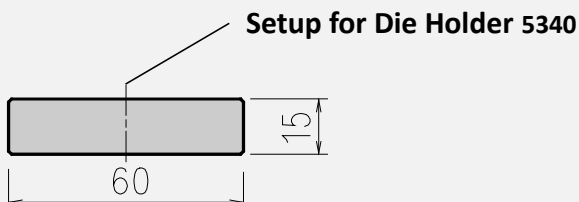

Length mm	Item No.	Weight Kg
L=1050mm	EH 5340011	7,4
S=450mm	EH 5340012	3,2

Die Holder 5330

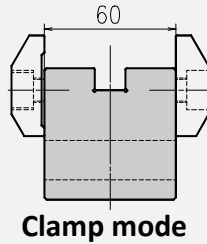
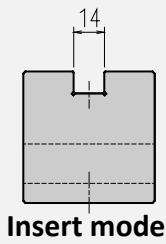
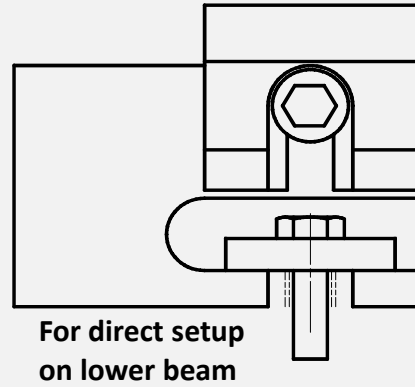
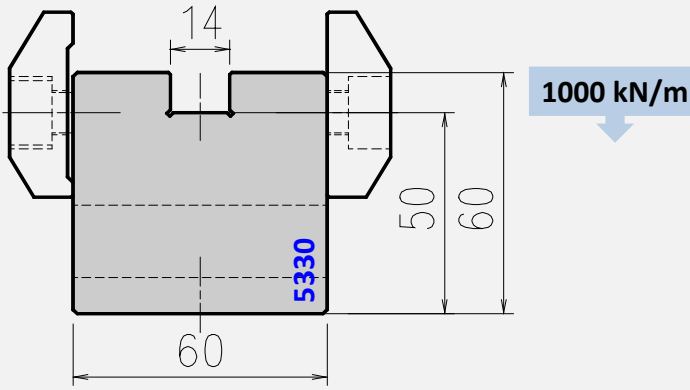

Holder 5330 replaces old holder 533

Length mm	Item No.	Weight Kg
L=1050mm	EH 5330001	32,3
S=450mm	EH 5330002	13,5

All mounting hardware is included.



Insert adaptor for polycarbonate dies (V4 to V12)

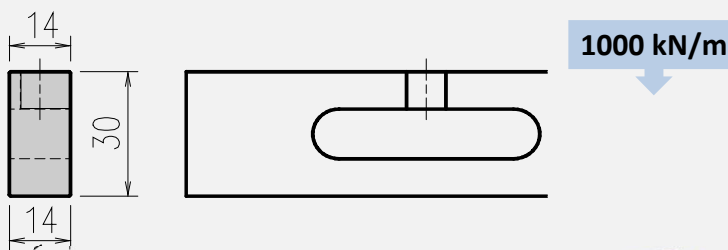

Length mm	Item No.	Weight Kg
L=834mm	EH 3300011	2,5
S=414mm	EH 3300012	1,2

All mounting hardware for polycarbonate dies is included.

Dimension for insert mode

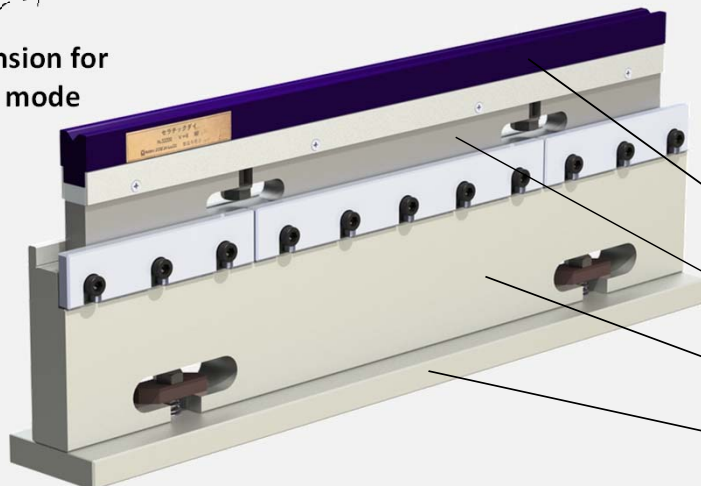

Polycarbonate Die DX 334002

Insert adaptor EH 3300012

Die Holder EH 5340002

Support for Die Holder EH 5340012

Die Holder 0550

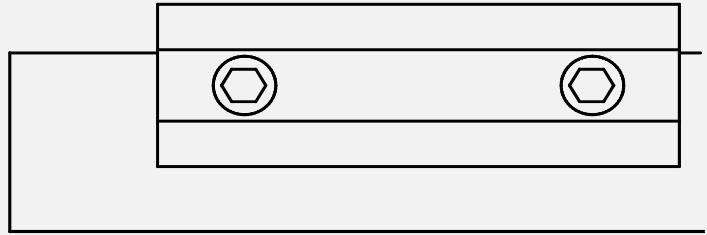
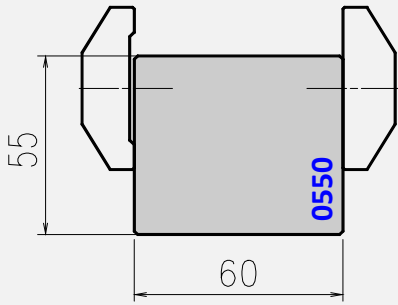

Holder 0550 replaces old holder 055

Length mm	Item No.	Weight Kg
L=835mm	EH 0550001	25,8
S=415mm	EH 0550002	13,5

Die Holder 0500

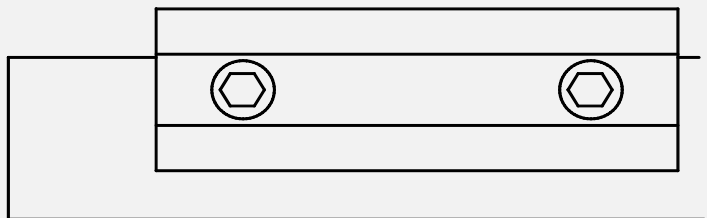
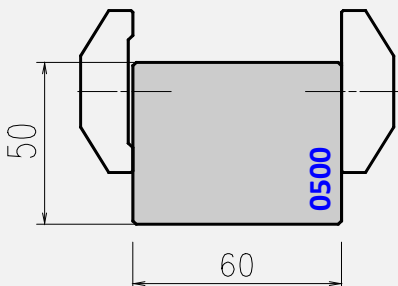

Holder 0500 replaces old holder 05008

Length mm	Item No.	Weight Kg
L=835mm	EH 0500001	23,8
S=415mm	EH 0500002	12,5

Die Holder for 2V reversible dies

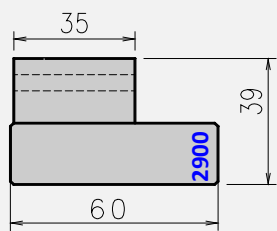

Holder 2900 replaces old holders 292 and 290

Length mm	H39 Item No.	Weight Kg
L=830mm	EH 2900001	10,8
S=412mm	EH 2900002	5,4

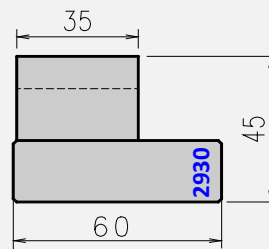

Holder 2930 replaces old holders 293

Length mm	H45 Item No.	Weight Kg
L=830mm	EH 2930001	12,3
S=412mm	EH 2930002	6,1

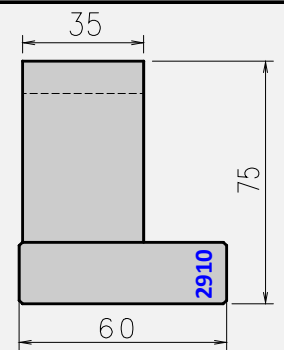

Holder 2910 replaces old holders 294 and 291

Length mm	H75 Item No.	Weight Kg
L=830mm	EH 2910001	17,6
S=412mm	EH 2910002	8,8

Die Holder for 2V reversible dies

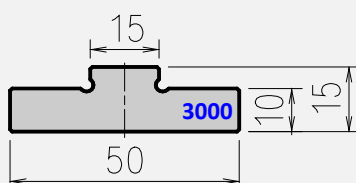

Holder 3000 replaces old rail 300

Length mm	Item No.	Weight Kg
L=835mm	EH 3000001	3,8
S=415mm	EH 3000002	1,9

Punch Holder SGRIP DUAL or SINGLE

DUAL

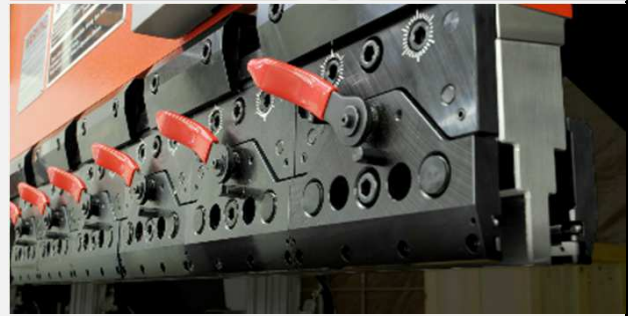
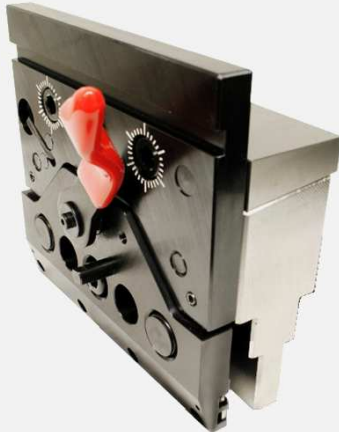
SINGLE

Note:

- Tonnage: 1000 kN/m
- Effective Height: 120mm
- Front loading, unloading possible
- Adjustment wedge allows next to each other location

	Length mm	Item No.	Weight Kg
DUAL	150	DX 903200	7,5
SINGLE	150	DX 903100	6,3

Punch Holder AGRIP-M DUAL

Note:

- Tonnage: 1000 kN/m
- Effective Height: 120mm
- Front loading, unloading possible
- Adjustment wedge allows next to each other location
- Accurate clamping, positioning and alignment

	Length mm	Item No.	Weight Kg
	150	DX 905200	7,5

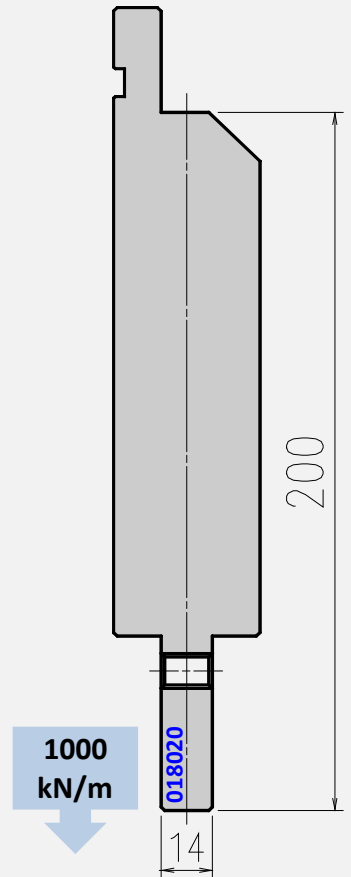
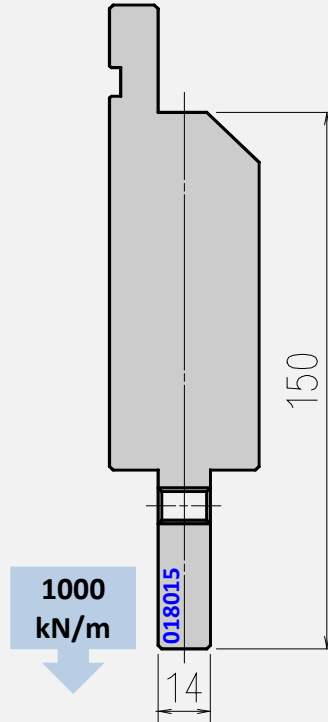
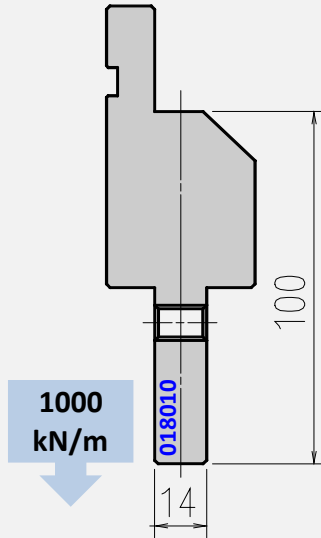
Distance piece 100
Distance piece 150
Distance piece 200

Note: Clamps are not included.

Holder 018010 replaces old ADA100

Holder 018015 replaces old ADA150

Holder 018020 replaces old ADA200

Length mm	Item No.	Weight Kg
150	EH 0180100	3,5

Item No.	Weight Kg
EH 0180150	5,9

Item No.	Weight Kg
EH 0180200	8,5

Narrow Punch Holder 913

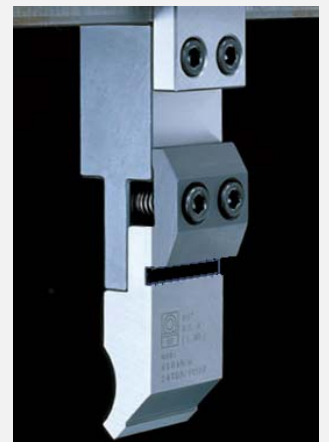
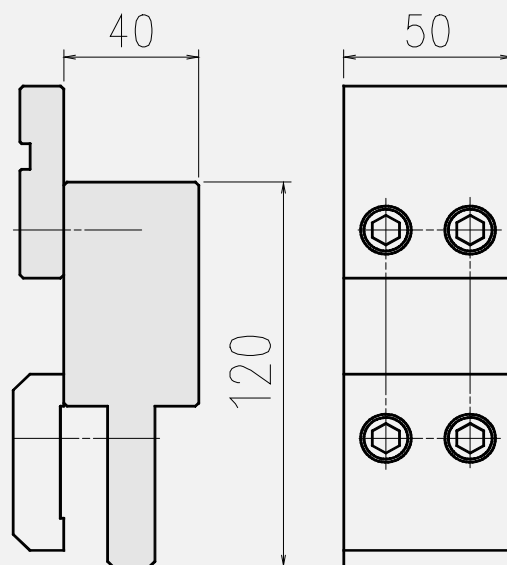

Length mm	Item No.	Weight Kg
50	AC 913000	3,0

Punch Holder 0150

Punch Holder 0160

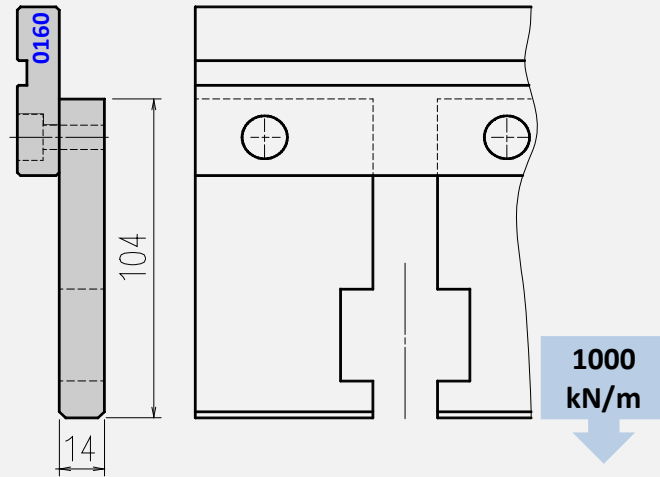
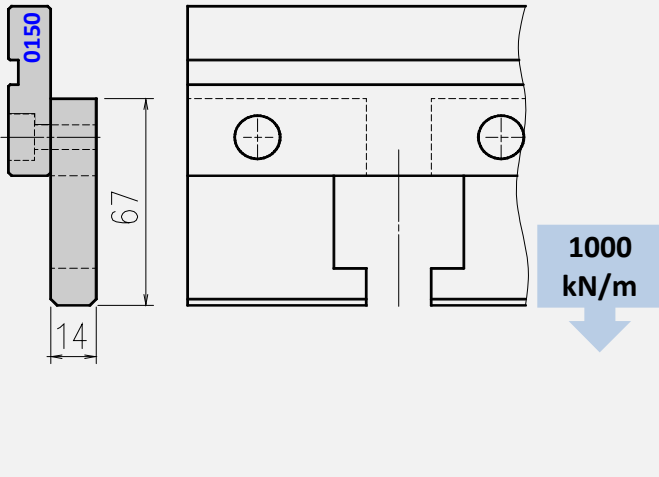

Holder 0150 replaces old holder 15

Length mm	Item No.	Weight Kg
830	EH 0150001	9,8
412	EH 0150002	4,9

Length mm	Item No.	Weight Kg
830	EH 0160001	13,3
412	EH 0160002	6,6

Deep bend Punch Holder

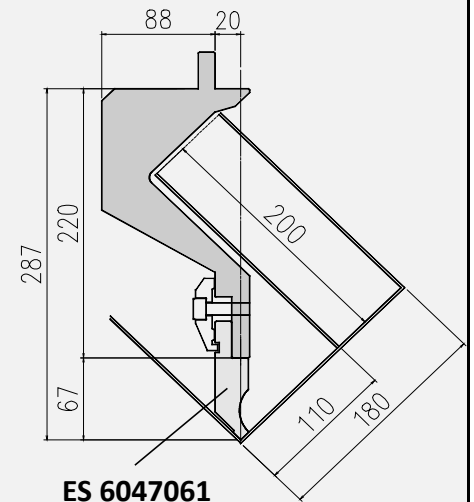
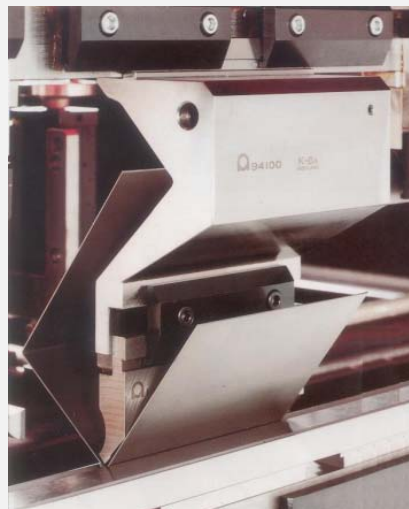
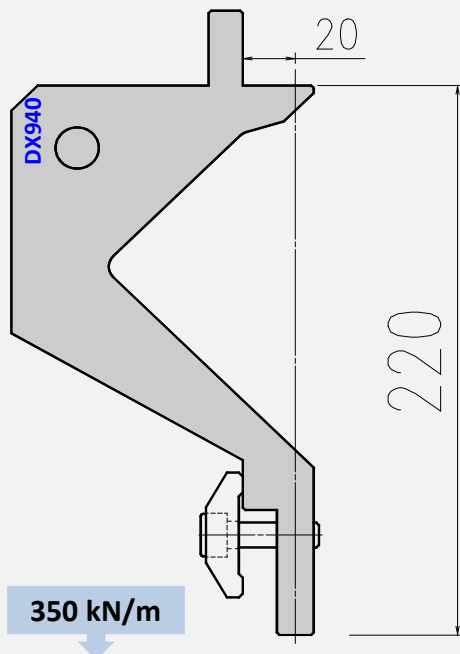

Length mm	Item No.	Weight Kg
200	DX 940000	18,0

Safety groove clamps available from stock :
Item No. 961000



Super Multi II

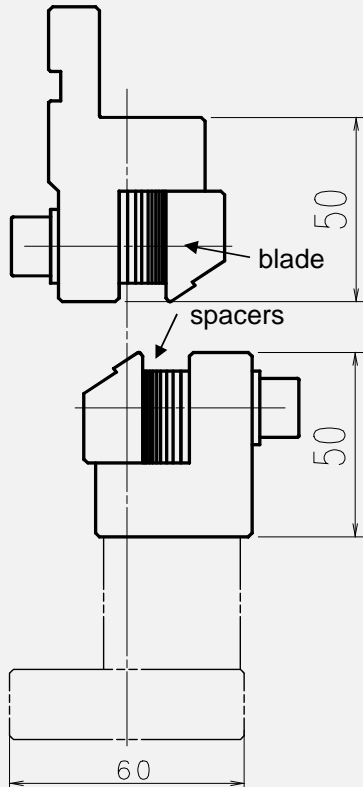

A variety of offset sizes in one tool !

Super multi tool-set is a versatile bending tool that achieves a variety of offset bendings by changing tooling offset in accordance with the spacer thickness.

- Sectionalized blade available
- Max. material thickness :
 - 2,3 mm (mild steel)
 - 1,5 mm (stainless)
 - 3,0 mm (Al)
- Tool Offset range $H_{\text{tool}} = 1,79 - 7,81$ mm
- Due to the air bending method, product offset value is differing from tool offset, so please ask for charts.

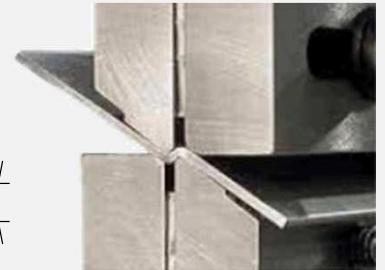
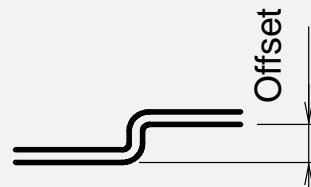

L-Set = 835 mm including all 835 mm spacers



S-Set = 415 mm including all 415 mm spacers

Length mm	Item No.	Wt. Kg
835	S20021	35,4
415	S20022	17,6

Replacement blades for Super Multi II

Blade 835 mm : S2B021



Blade 415 mm : S2B022



Sectional Blade 415 mm (10, 15, 20, 40, 50, 100, 180) : S2B802



Length mm	Item No.	Wt. Kg
835	S2B021	2,6
415	S2B022	1,3
415 sec.	S2B802	1,3

Alignement jig for Super Multi II

guarantee perfect alignment and finest adjustments in all planes (Set includes 2 pcs.)

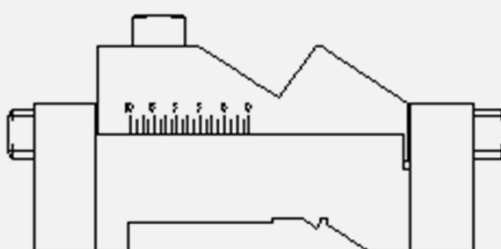

20 kN/m

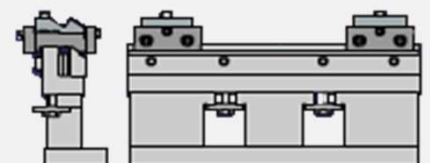

Item No.	Wt. Kg
S20030	3,0

90° Side gauge 930



Note:

- Max. 60 mm die width
- Left-gauging or right-gauging
- Fixation on die

Item No.	Weight [Kg]
AC 930000	2,0

90° Side gauge for 1V dies 939

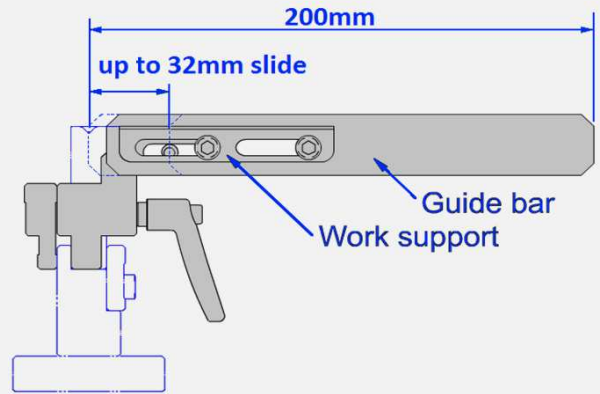

Note:

- Left-gauging or right-gauging
- Fixation on die holder

Item No.	Weight [Kg]
AC 939000	1,0

Angle adjustable side gauge 932

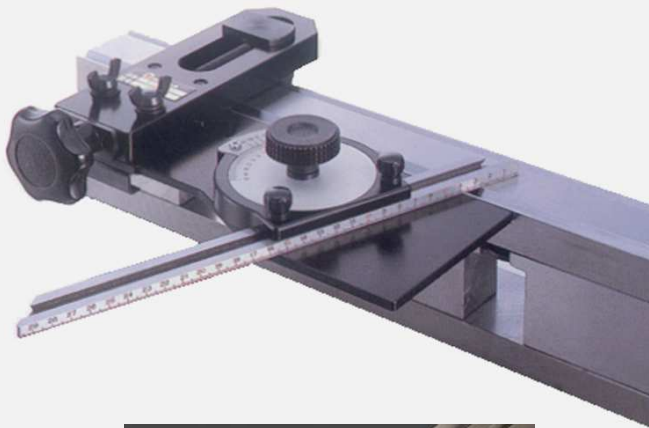

Note:

- Fixation on die (1V or 2V dies)
- Left-gauging or right-gauging
- Indexable within 100° (at 5' increments)

Item No.	Weight [Kg]
AC 932000	2,6

Digital angle gauge 9351



Note:

- Shows bending angle in real time
- Resolution of 0,1°
- Use only with magnetisable sheet metal

Item No.	Weight [Kg]
AC 935100	0,2

Closing tool

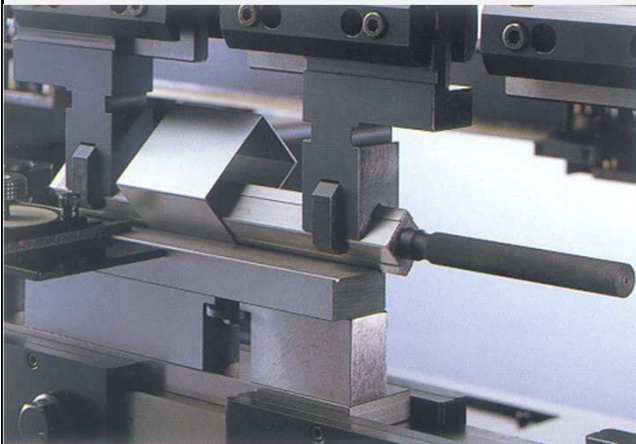
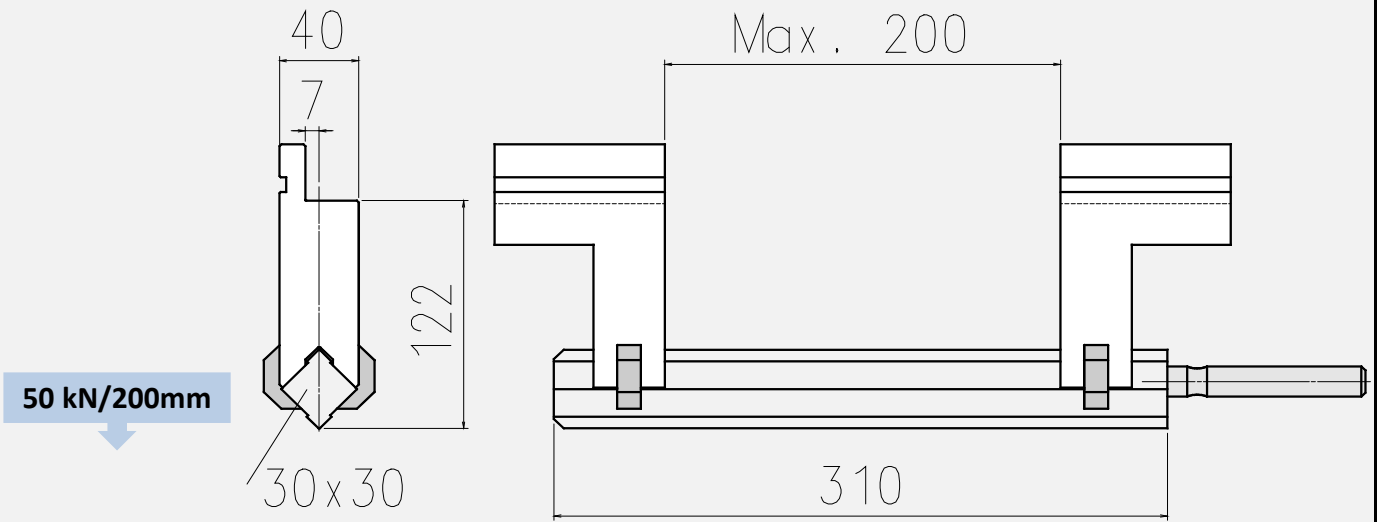

Guidance for thickness and V opening by tool gap:

Tool gap	Mild steel	Stainless steel	Aluminum
100mm	t ≤ 4,5 ≥ V40	t ≤ 2,5 ≥ V25	t ≤ 5,0 ≥ V32
150mm	t ≤ 2,3 > V16	t ≤ 1,5 ≥ V12	t ≤ 3,0 ≥ V18
200mm	t ≤ 1,6 > V10	t ≤ 0,8 ≥ V6	t ≤ 2,0 ≥ V10

Tool angle	Radius mm	Item No.	Weight Kg
88°	R0,6	C00010	6,0

Note:

- Please minimize tool gap, according to sheet part

"BendingTool"

The bending app by Amada

Using BendingTool you can quickly calculate on the spot:

- Press force
- Press force table
- Bend deduction
- Sheet gauge conversion
- Weight of sheet
- Box bending parameters
- Return bend graphs

The BendingTool is available free for iOS in the app store.

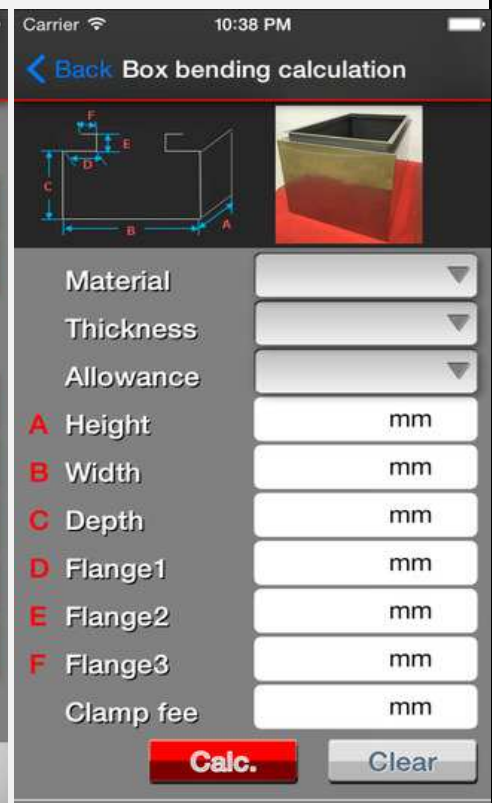

Type VLMBN

Minimum die angle	30°
V-Opening	adjust. each 10mm ca. V25 - V125
Sheet thickness	3 - 15 mm
Shoulder Radius	R8 mm
Die length	500 mm
Max. allowable tonnage	1250 kN/m
Hardness Radius inserts	HRC 60
Spacers:	5; 10; 15; 20

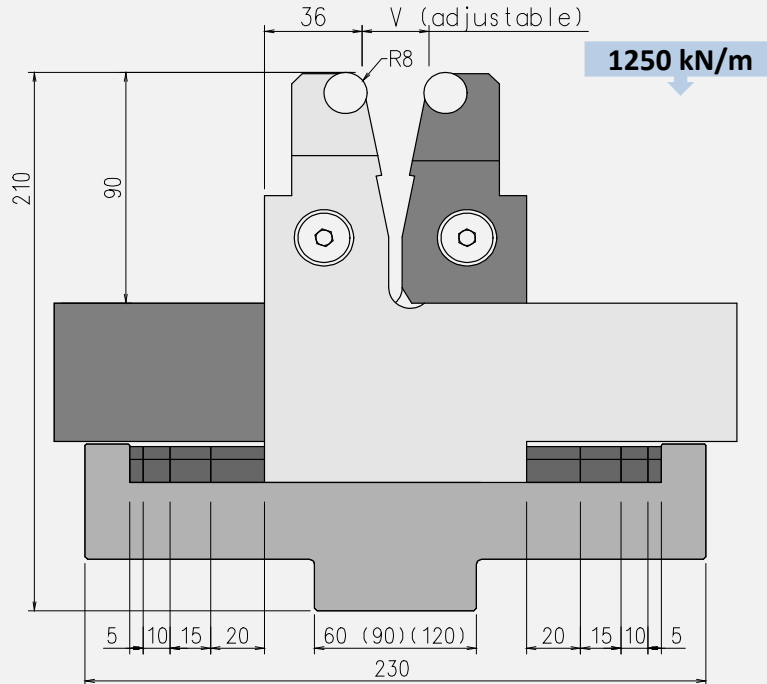

	for 60mm beam	for 90mm beam	for 120mm beam
Set	BN1-500S 96	BN2-500S 99	BN3-500S 99
only Holder	BN1-500H 33	BN2-500H 36	BN3-500H 36

	Item No.	Weight Kg
only Die	BN 500D	58
only spacers	BN-500I	5,3
only strip	ACBN150	0,1

Type VLMDN

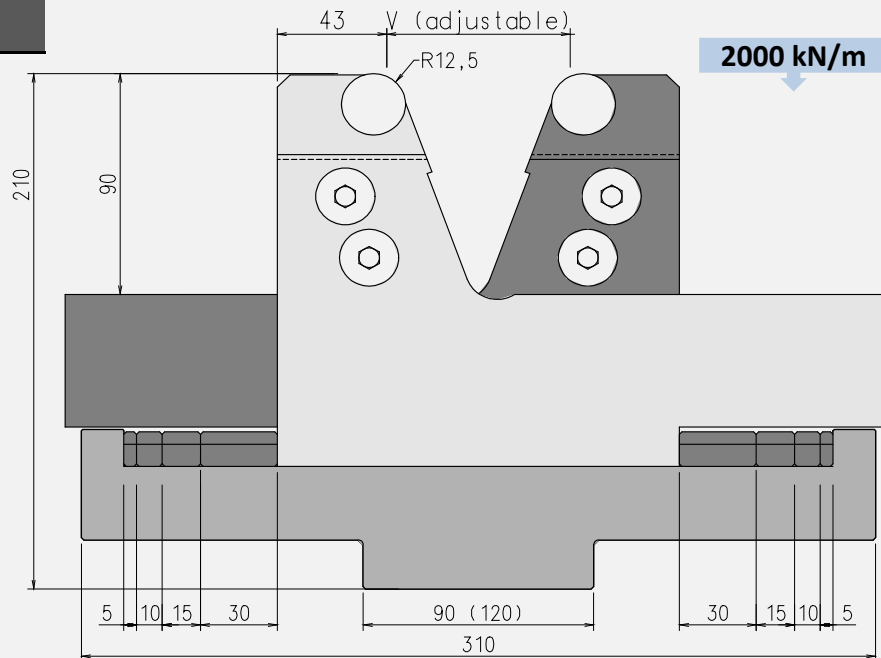
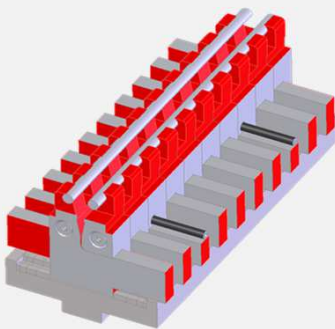
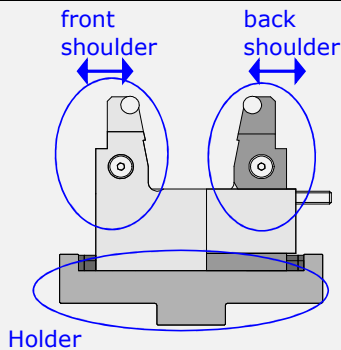

	for 90mm beam	for 120mm beam
Set	DN2-500S 137,1	DN3-500S 44,6
only Holder	DN2-500H 44,6	DN3-500H 44,6

	Item No.	Weight Kg
only Die	DN 500D	86
only spacers	DN-500I	6,4
only strip	ACDN150	0,1

Minimum die angle	60°
V-Opening	adjust. each 10mm ca. V70 - V190
Sheet thickness	3 - 20 mm
Shoulder Radius	R12,5 mm
Die length	500 mm
Max. allowable tonnage	2000 kN/m
Hardness Radius inserts	HRC 60
Spacers:	5; 10; 15; 30

WingBend bending features

- very small flanges
- wide range of materials using the same die
- small bend radii
- bends closer to holes
- forming oblique flanges
- less scratches
- scratch-free bending for film protected sheet metal

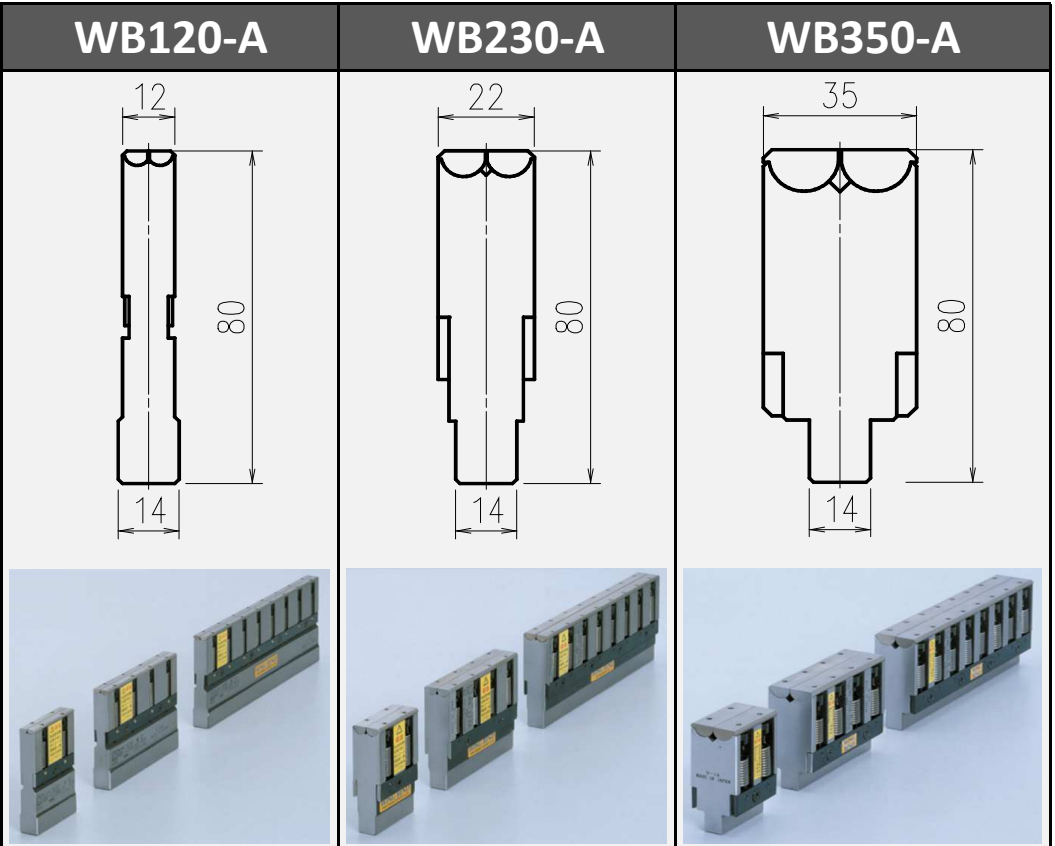

Equivalent die opening		up to V6	up to V10	up to V15
Mat. thickness	Mild steel	0,5 ~ 1,2	0,5 ~ 2,3	1,0 ~ 3,2
	Stainless steel	0,5 ~ 1,0	0,5 ~ 2,0	1,0 ~ 3,0
	Aluminium	0,5 ~ 1,0	0,5 ~ 2,0	1,0 ~ 3,0
Min. angle		80°	80°	80°
Tonnage		1000 kN/m	1000 kN/m	1000 kN/m
Code per tool length	50mm	70120A	70230A	70350A
	100mm	70120B	70230B	70350B
	200mm	70120C	70230C	70350C

Tonnage and process data:

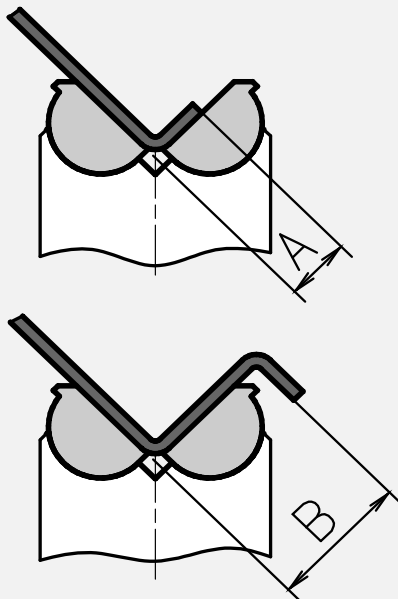

How to read table data:

Tonnage (kN/m)			
A	Min. flange length (mm)		B
		Min. offset value (mm)	

t (mm)	WB120-A		WB230-A		WB350-A	
0,5	50		50		40	
	3,6	7,3	5,7	12,2	8,1	19,3
0,8	100		70		50	
	3,8	7,4	5,9	12,4	8,4	19,5
1	150		80		60	
	4,0	7,4	6,1	12,6	8,6	19,7
1,2	240		110		70	
	4,1	7,5	6,2	12,7	8,8	19,9
1,6			200		140	
			6,4	12,9	9,0	20,2
2			300		200	
			6,6	13,0	9,4	20,4
2,3			400		260	
			6,8	13,2	9,6	20,6
2,6					340	
					9,8	20,8
3,2					510	
					10,2	21,0

Note:

- this chart is showing bending data for mild steel
- bending operation in the dark range is not recommended
- Min. flange length and min. offset value are reference values

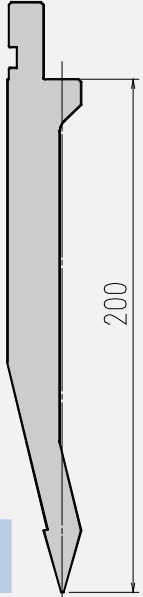
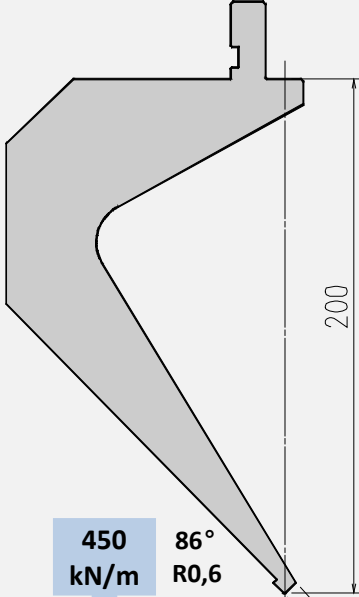
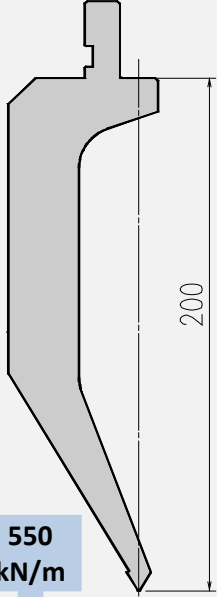
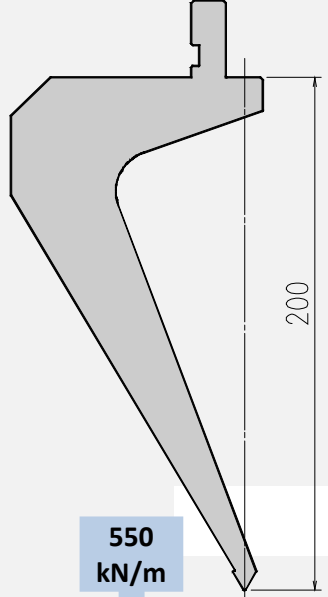
Punch Type 831 H200 30°-R0,6		Punch Type 846 H200_W110 86°-R0,6		Punch Type 841 H200_W55 60°-R0,6		Punch Type 841 H200_W95 60°-R0,6	
Item No. SE 8310012		Item No. SE 8460012		Item No. SE 8410012		Item No. SE 8410022	
Tool length	415	Tool length	415	Tool length	415	Tool length	415
Weight (Kg)	12,2	Weight (Kg)	27,2	Weight (Kg)	16,8	Weight (Kg)	22,4
 <p style="text-align: center;">200</p> <p style="text-align: center;">800 kN/m</p> <p style="text-align: center;">30° - R0,6</p>		 <p style="text-align: center;">200</p> <p style="text-align: center;">450 kN/m 86° R0,6</p> <p style="text-align: center;">6</p>		 <p style="text-align: center;">200</p> <p style="text-align: center;">550 kN/m</p> <p style="text-align: center;">60° - R0,6</p>		 <p style="text-align: center;">200</p> <p style="text-align: center;">550 kN/m</p> <p style="text-align: center;">60° - R0,6</p>	

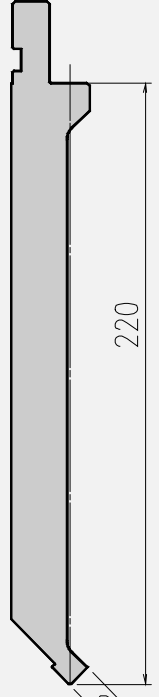
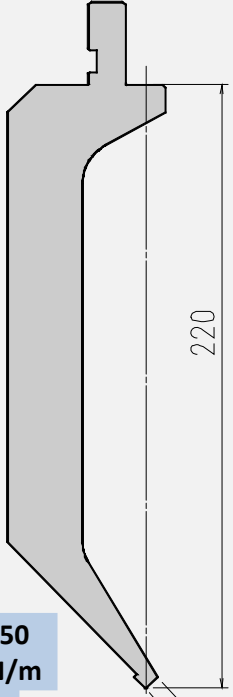
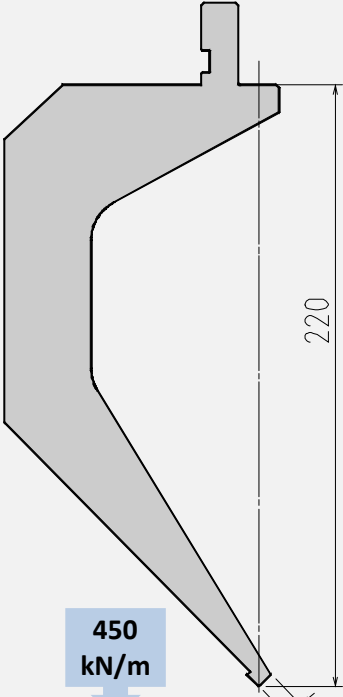
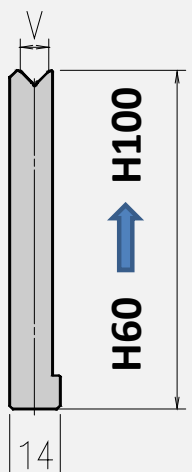
Punch Type 804 H220 86°-R0,6		Punch Type 846 H220_W55 86°-R0,6		Punch Type 846 H220_W95 86°-R0,6		Semistandard dies	
Item No. SE 8040012		Item No. SE 8460022		Item No. SE 8460032		Item No. ---	
Tool length	415	Tool length	415	Tool length	415	Tool length	835
Weight (Kg)	14,9	Weight (Kg)	19,4	Weight (Kg)	25,9	Weight (Kg)	---
 <p style="text-align: center;">220</p> <p style="text-align: center;">800 kN/m</p> <p style="text-align: center;">86° - R0,6</p>		 <p style="text-align: center;">220</p> <p style="text-align: center;">450 kN/m</p> <p style="text-align: center;">86° - R0,6</p> <p style="text-align: center;">6</p>		 <p style="text-align: center;">220</p> <p style="text-align: center;">450 kN/m</p> <p style="text-align: center;">86° - R0,6</p> <p style="text-align: center;">6</p>		<p>All AFH standard dies, up to V25 opening, can be ordered in AMANIT® quality with 100mm special height.</p>  <p style="text-align: center;">H60 H100</p> <p style="text-align: center;">14</p>	
<ol style="list-style-type: none"> All punches with 1000 N/mm² body strength and 54-58 HRC tip hardness According to your requirements please ask for special tip radius, special sectionalized lengths, special ear shapes (considering the reduced tonnage capacity) Without non corrosive coating on punch body See chapter "Tables and Graphs" for return bend area details 							

Large-radius bending

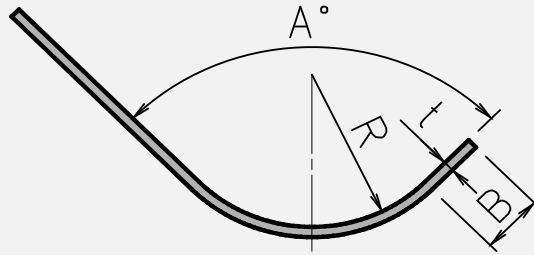
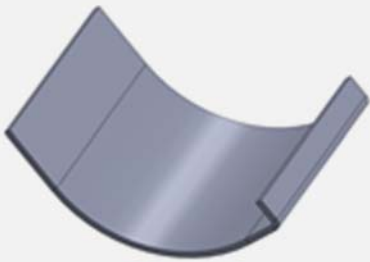

Note:

- please check the option to use step-bending process
- for mild steel ($3t < R < 30t$), R value will vary around $\pm 5\%$
- for $R \geq 30t$ less accuracy should be considered
- for $B < 10t$ air bending is not recommended

Using air-bending tools

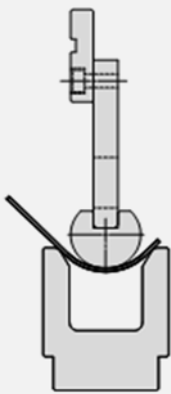

Using counterpressure

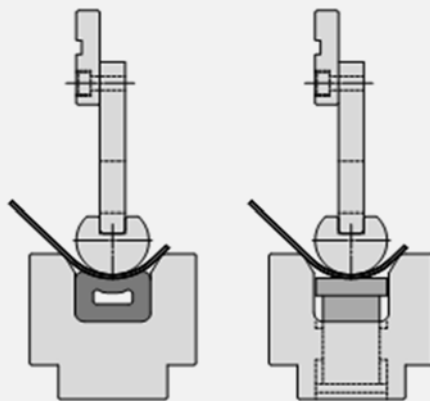

Using coining tools

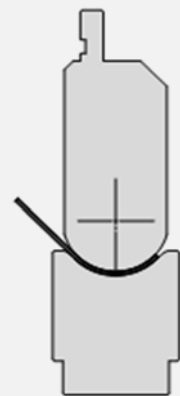

Offset bending

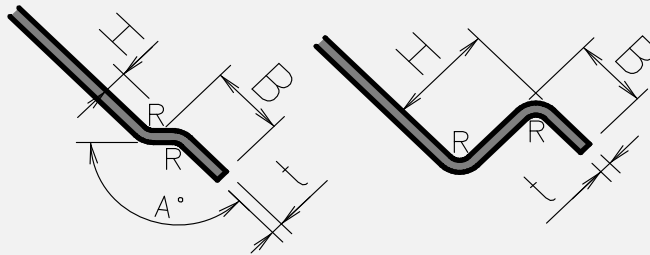
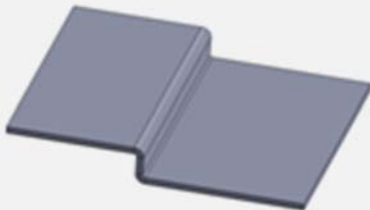

Note:

- please check the option to use standard offset tools
- best results for $R \approx 0,3H$; $B = 1,4H + 5\text{mm}$; $H < 12\text{mm}$ (mild steel)
- H results will vary around $\pm 0,2\text{mm}$
- for $H < 2,8t$ less accuracy



Hat bending

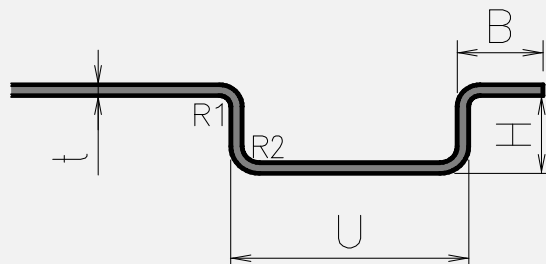
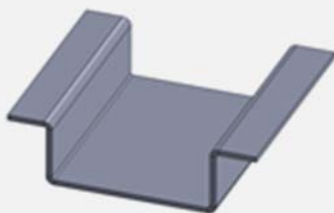

Note:

- best results for $R1 \approx t$; $R2 \approx 2t$; $H \approx (5t \text{ bis } 15\text{mm})$ $U \approx (4t \text{ bis } 30\text{mm})$
- H and U results will vary around $\pm 0,2\text{mm}$
- for $B < 10t$ less accuracy

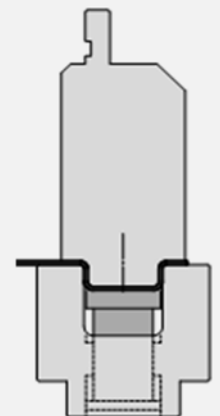

U bending

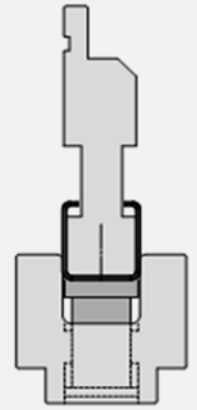
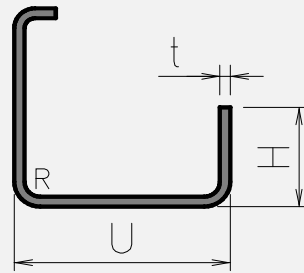
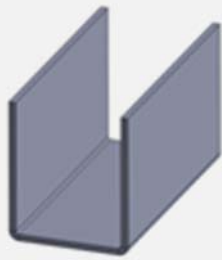

Notes:

- best results for $R \approx t$; $U \approx (4t \text{ bis } 30\text{mm})$
- U results will vary around $\pm 0,2\text{mm}$
- top side of the U shape could slightly open

Beading (longitudinal to the bending line)

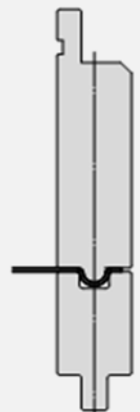
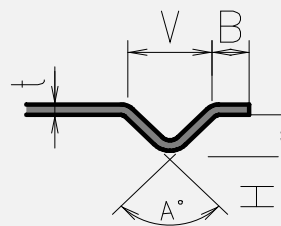
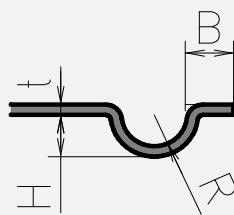
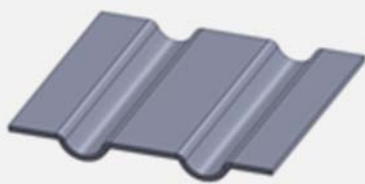

Note:

- best results for $R \approx (3t \text{ bis } 10\text{mm})$;
 $V \approx (4t \text{ bis } 30\text{mm})$ and $A > 60^\circ$ (mild steel)
- H results will vary around $\pm 0,2\text{mm}$
- for $B < 10t$ less accuracy

Beading (transversal to the bending line)

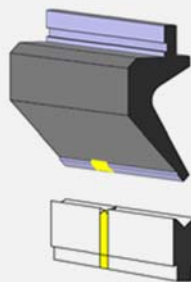

Needed data:

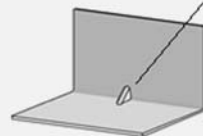
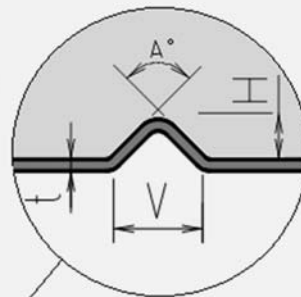

Flattening

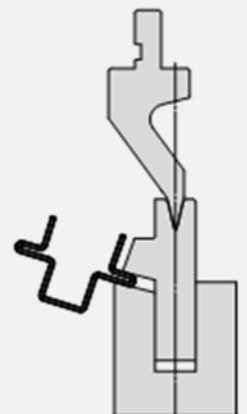
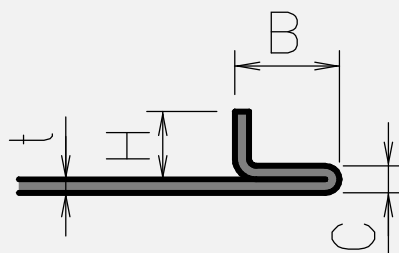
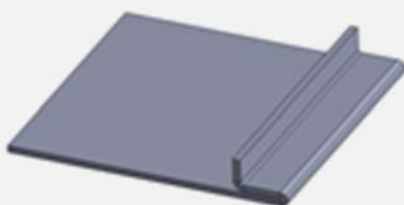

Note:

- for $C = 2t$ high bending force is required
- for more complex parts double-deck type tools are not possible
- higher flange of $H > B$ could cause tonnage problems

Determination of customized bending sequences

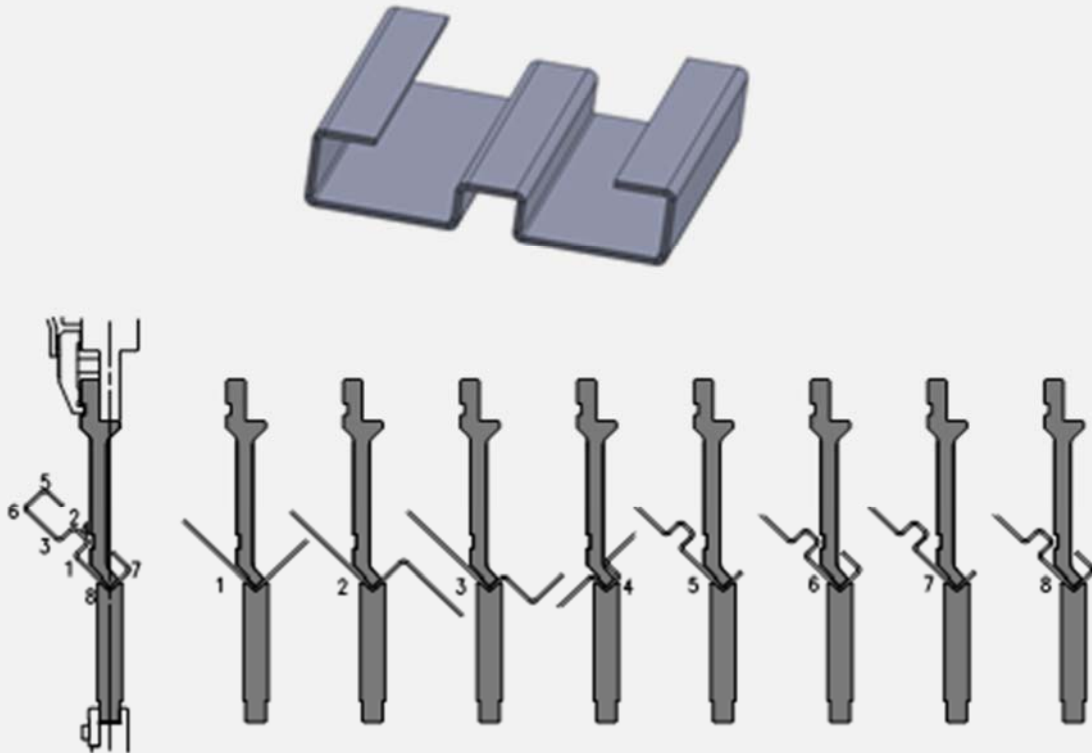

Conversion Adaptors

Amada offers adapting solutions for press brakes with Non-Amada style tooling. The advantage of these adaptors is the short and adjustable height in order to optimize open height of the press brake. For an offer, all Non-Amada dimensions are needed.

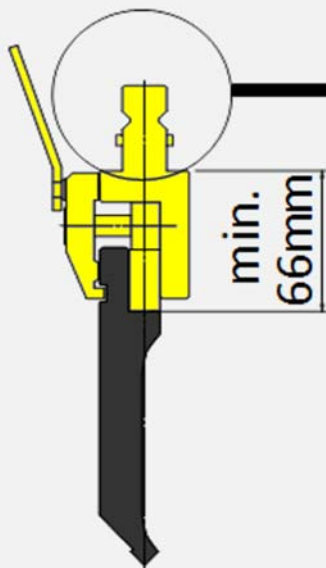

Height-adjustable adaptor for punches:

From NON-AMADA system
(Beyeler, LVD, Wila, ...)
to AMADA

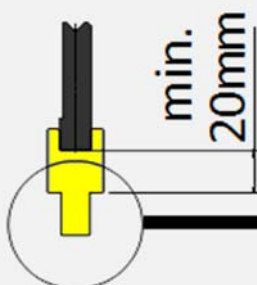

Adaptor for Dies:

From NON-AMADA system
(Beyeler, LVD, Wila, ...)
to AMADA (Insert, Reversible, Direct)



Tooling profile change for punches

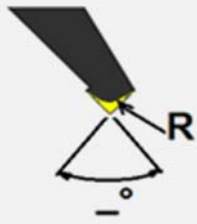

Modifications of the tool parameters

due to "throughhardened" quality, Amada tools have same hardness after modification (heat treatment is not necessary)

- Angle modifications (for sprinback compensations)
- Tip radius modifications
- Regrinding and repairing
- Modifications of the length or special section widths
- Special coatings against galling and special marking on request

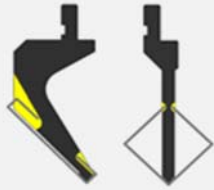

Modifications according to the shape of the sheet metal part

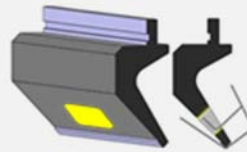

Modifications of the punch body for closed bending



Due to highest strenght of the body, Amada tools can be modified much thinner than conventional tools

- Modifications for very thin U-shaped sheet metal parts
- Modifications for very close C-shaped sheet metal parts



Modifications of the ear tool (length and profile)



Rulers with special radii

Tooling profile change for dies

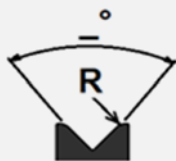

Modifications of the tool parameters

- Angle modifications (for sprinback compensations)
- Shoulder radius modifications (for less marks)
- Regrinding and repairing
- Modifications of the length or special section widths
- Special coatings against galling and special marking on request



Modifications according to the shape of the sheet metal part

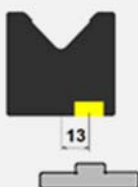

Adaptions for the reversible system



Adaptions for the insert system

RETURN BEND LIMIT GRAPH
PUNCH 804

[← Back to index](#)

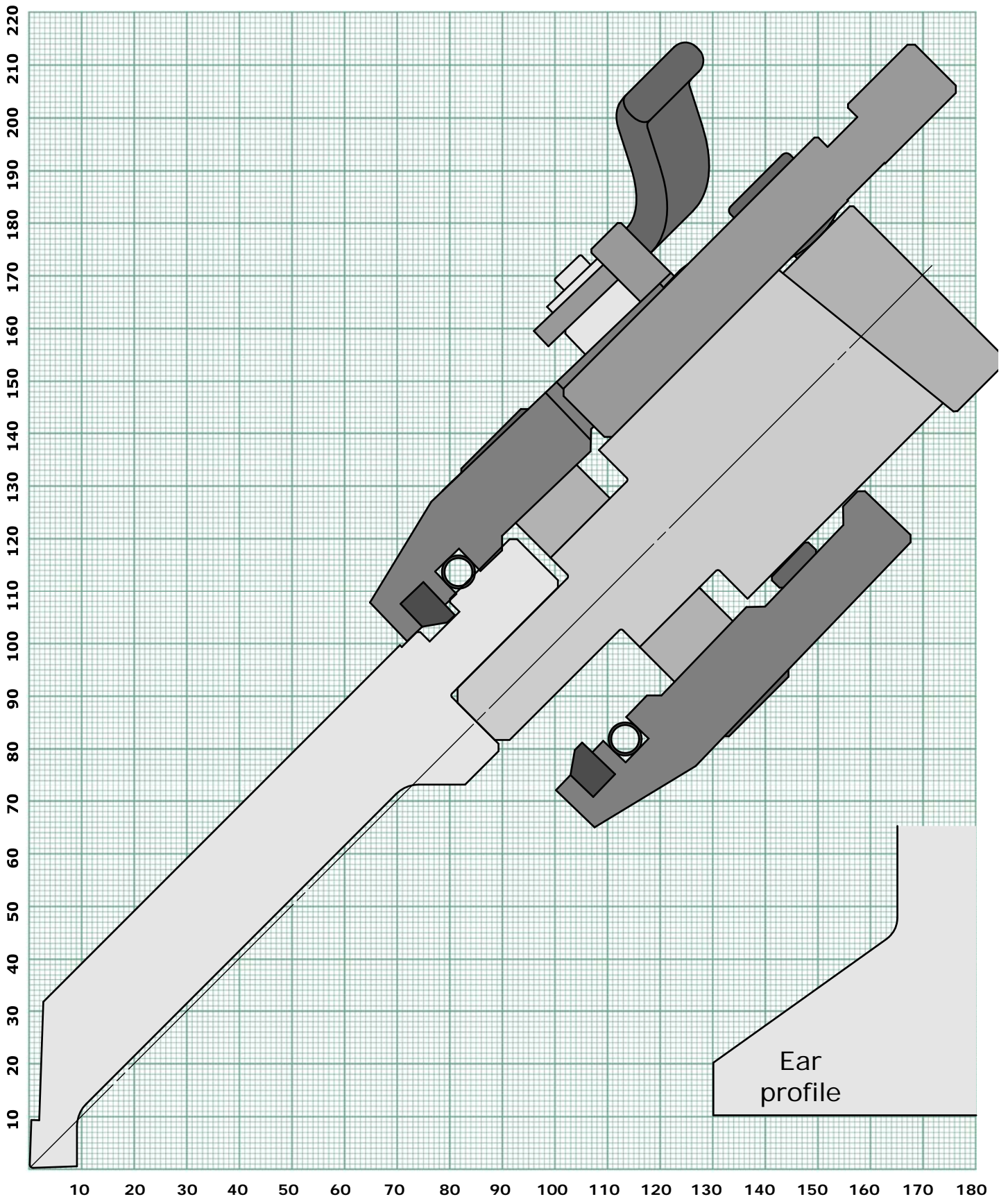

RETURN BEND LIMIT GRAPH
PUNCH 817

[← Back to index](#)

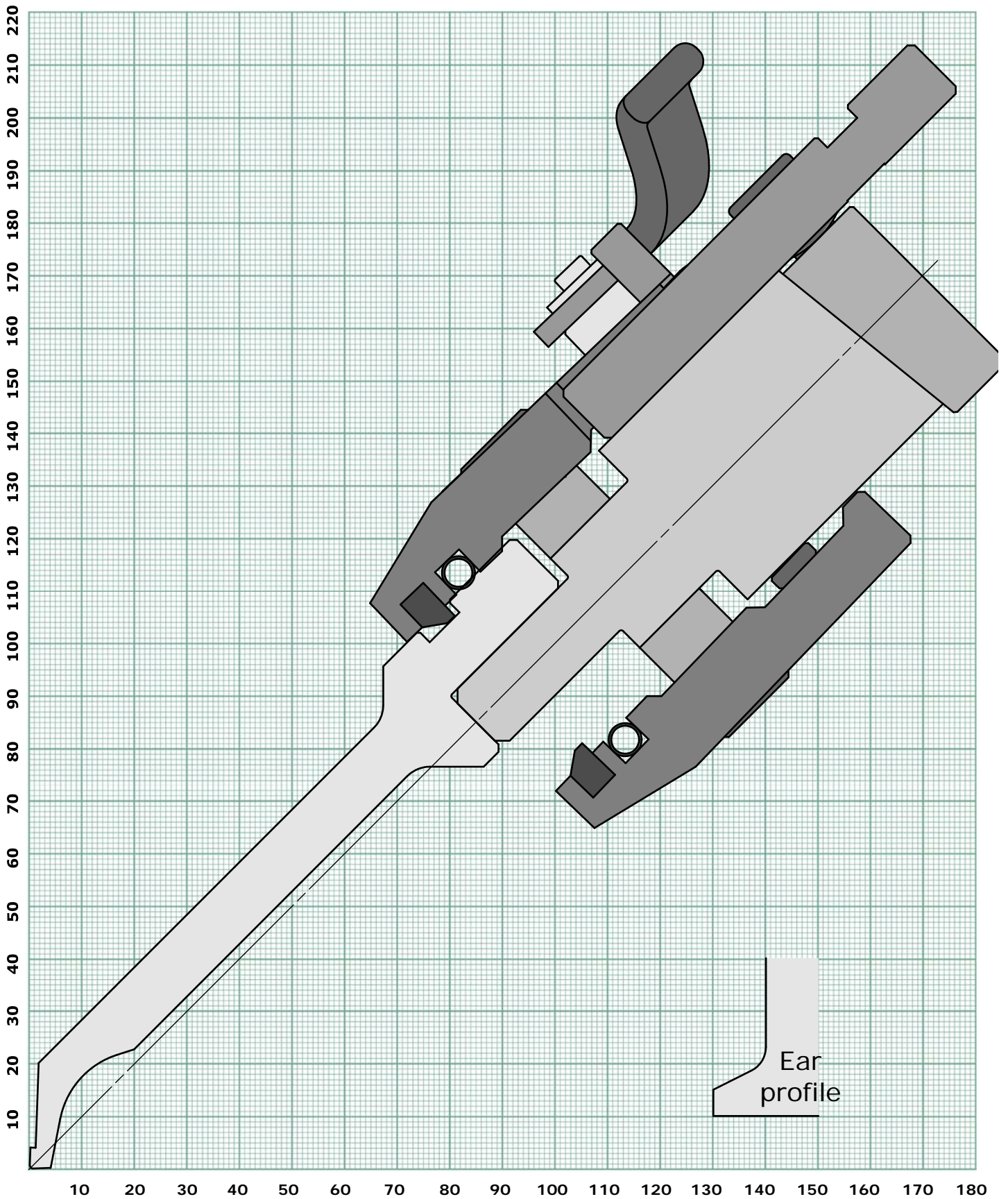

RETURN BEND LIMIT GRAPH
PUNCH 814

[← Back to index](#)

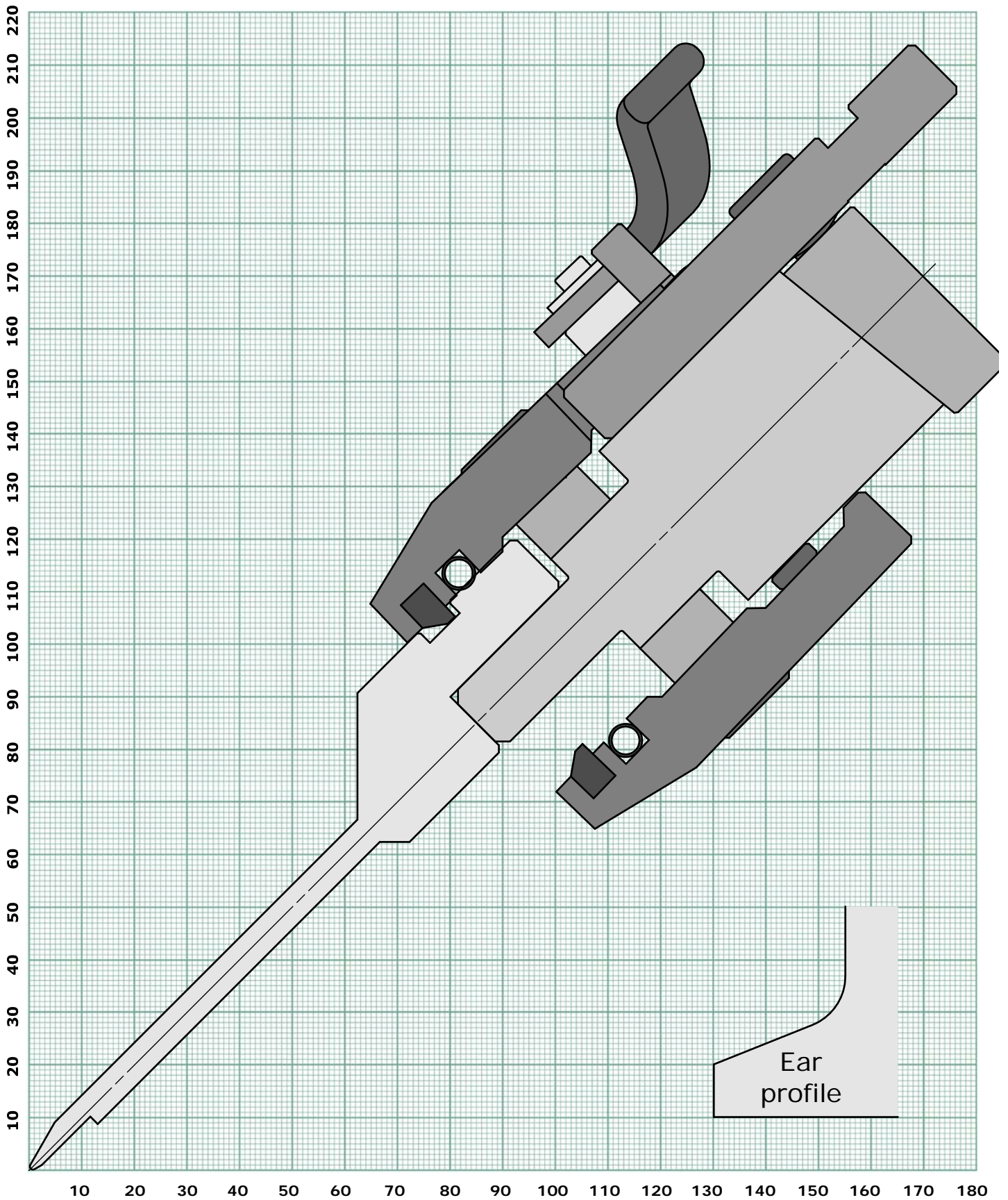

RETURN BEND LIMIT GRAPH
PUNCH 820

[← Back to index](#)

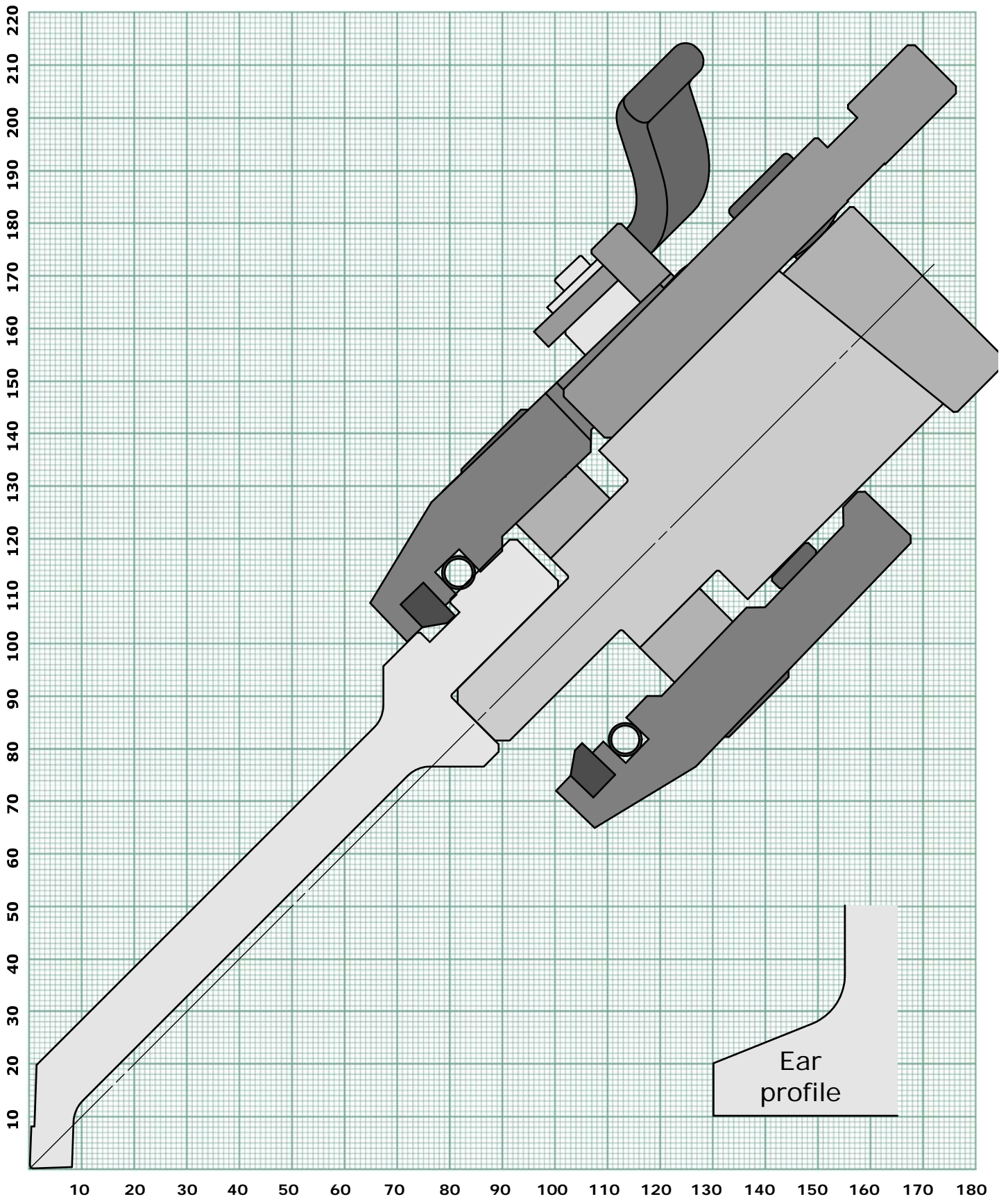

RETURN BEND LIMIT GRAPH
PUNCH 831-R0,6

← Back to index

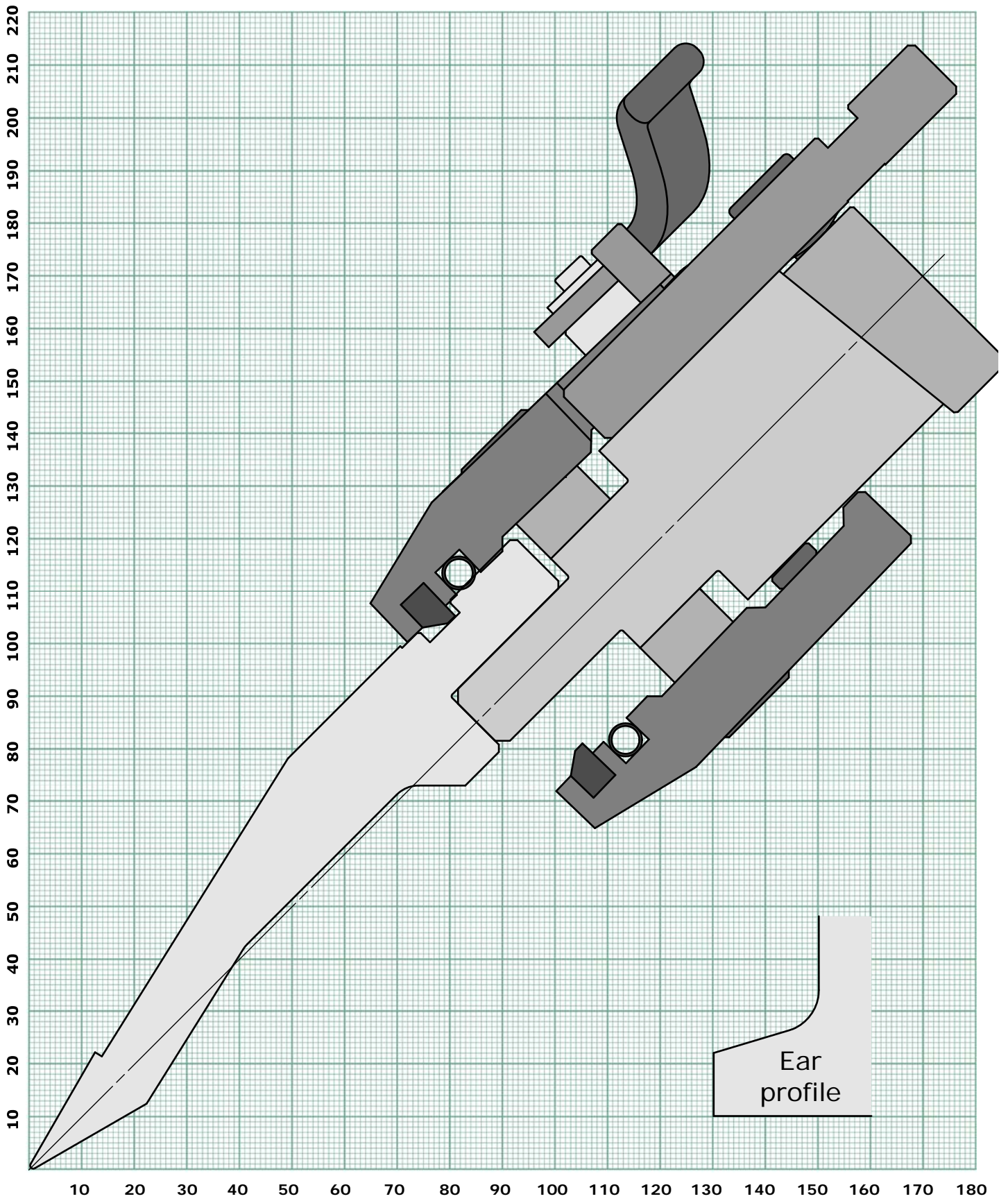

RETURN BEND LIMIT GRAPH
PUNCH 831-R3

[← Back to index](#)

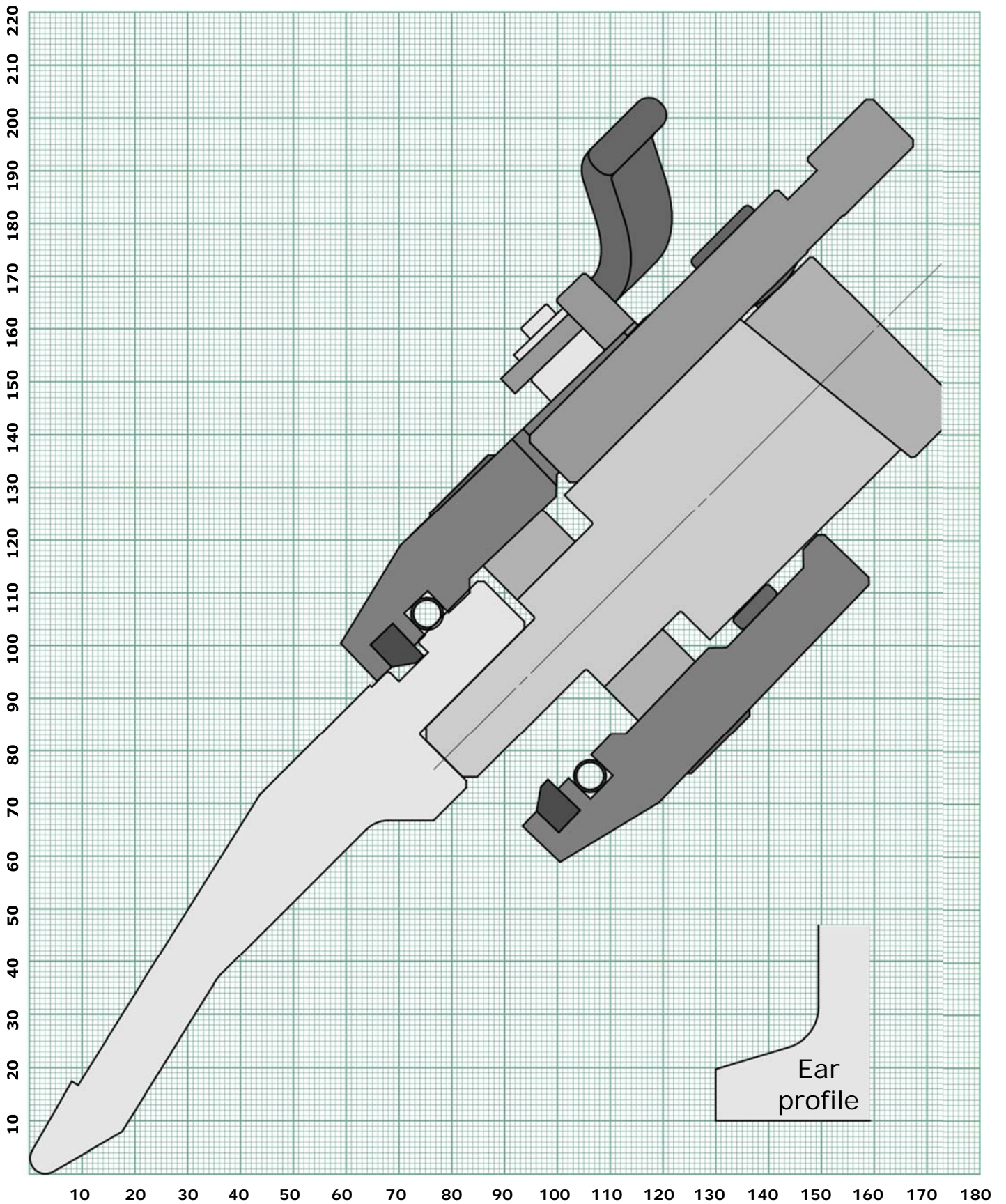

RETURN BEND LIMIT GRAPH
PUNCH 831-R4

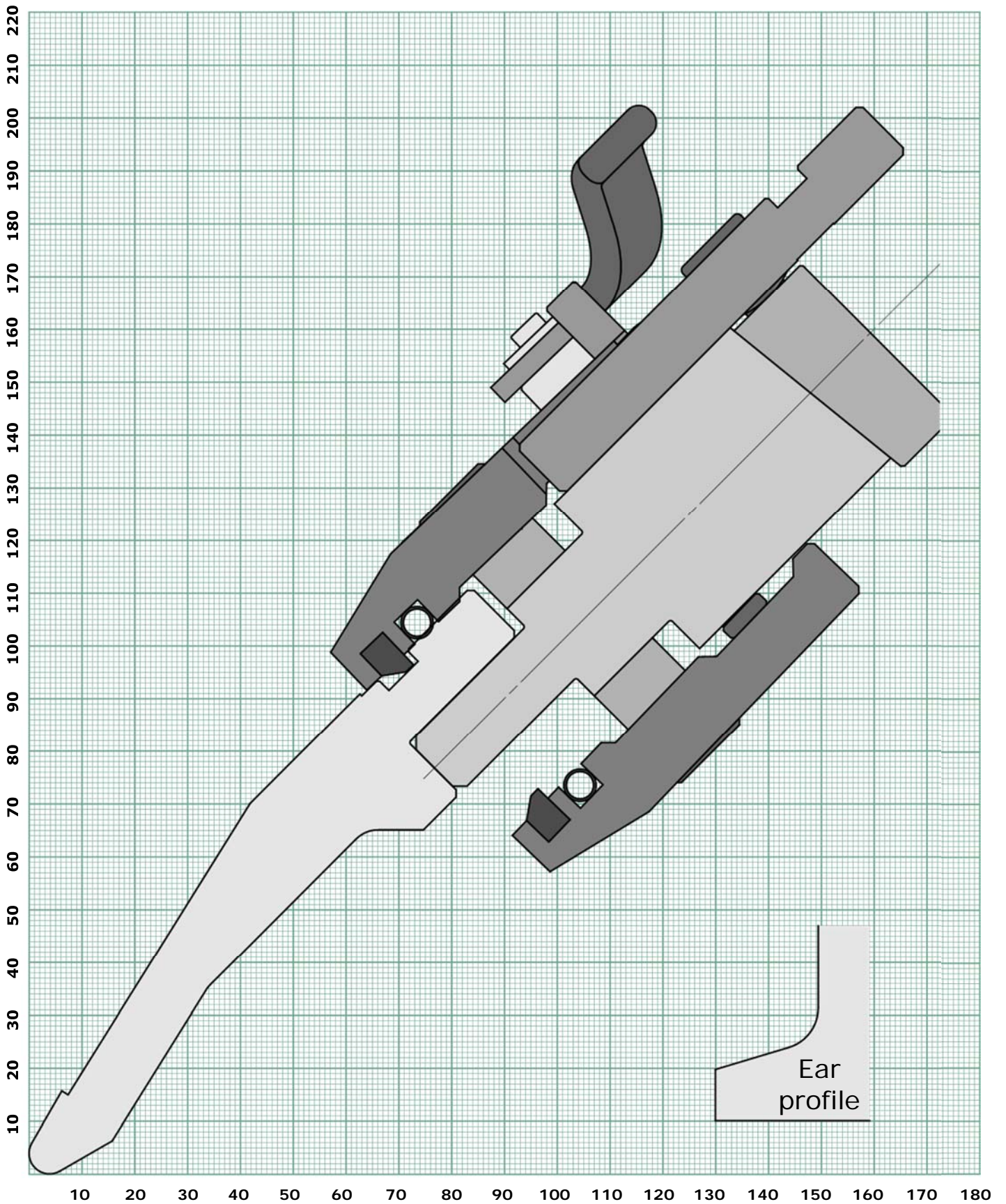

RETURN BEND LIMIT GRAPH
PUNCH 840

← Back to index

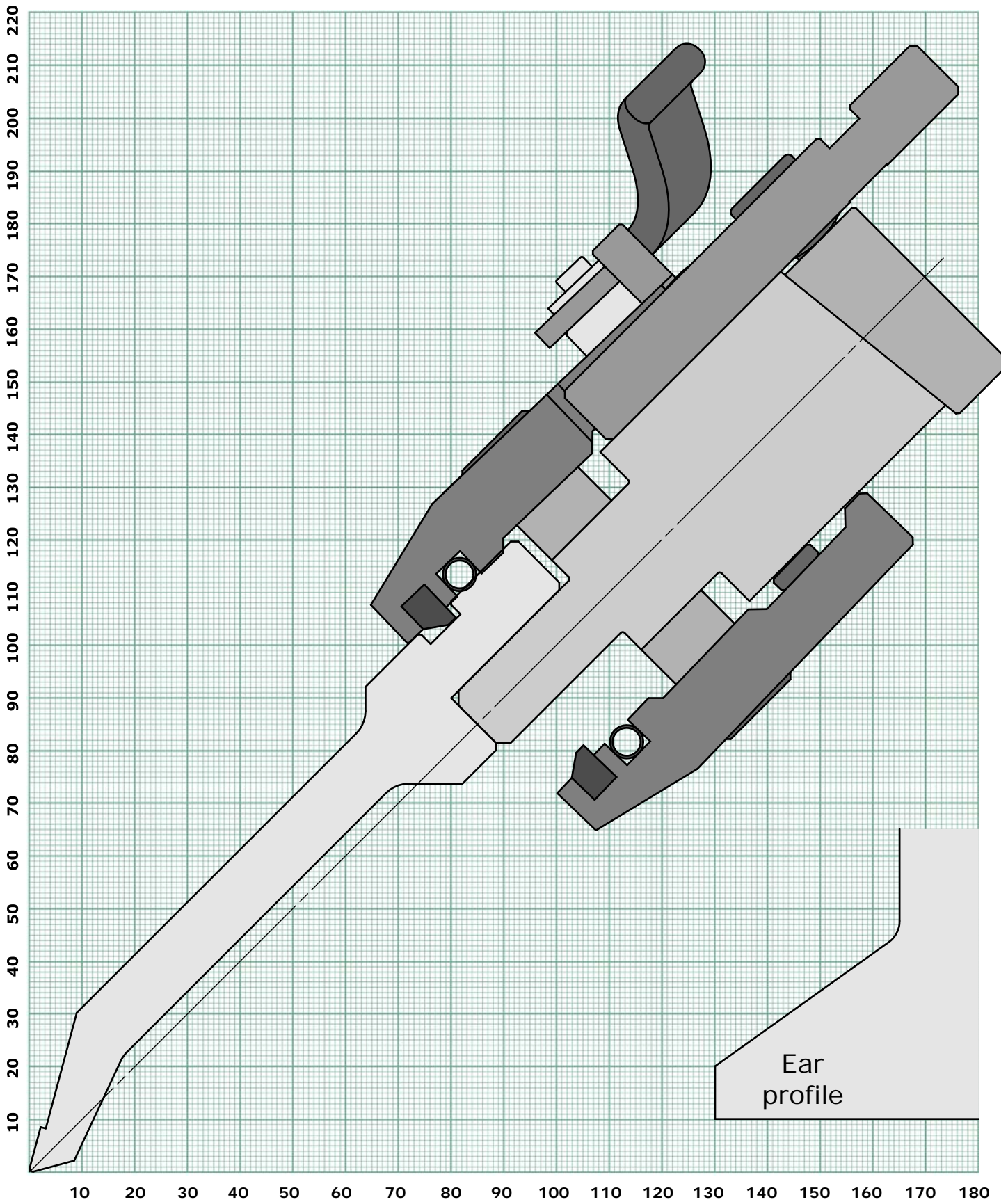

RETURN BEND LIMIT GRAPH
PUNCH 841

← Back to index

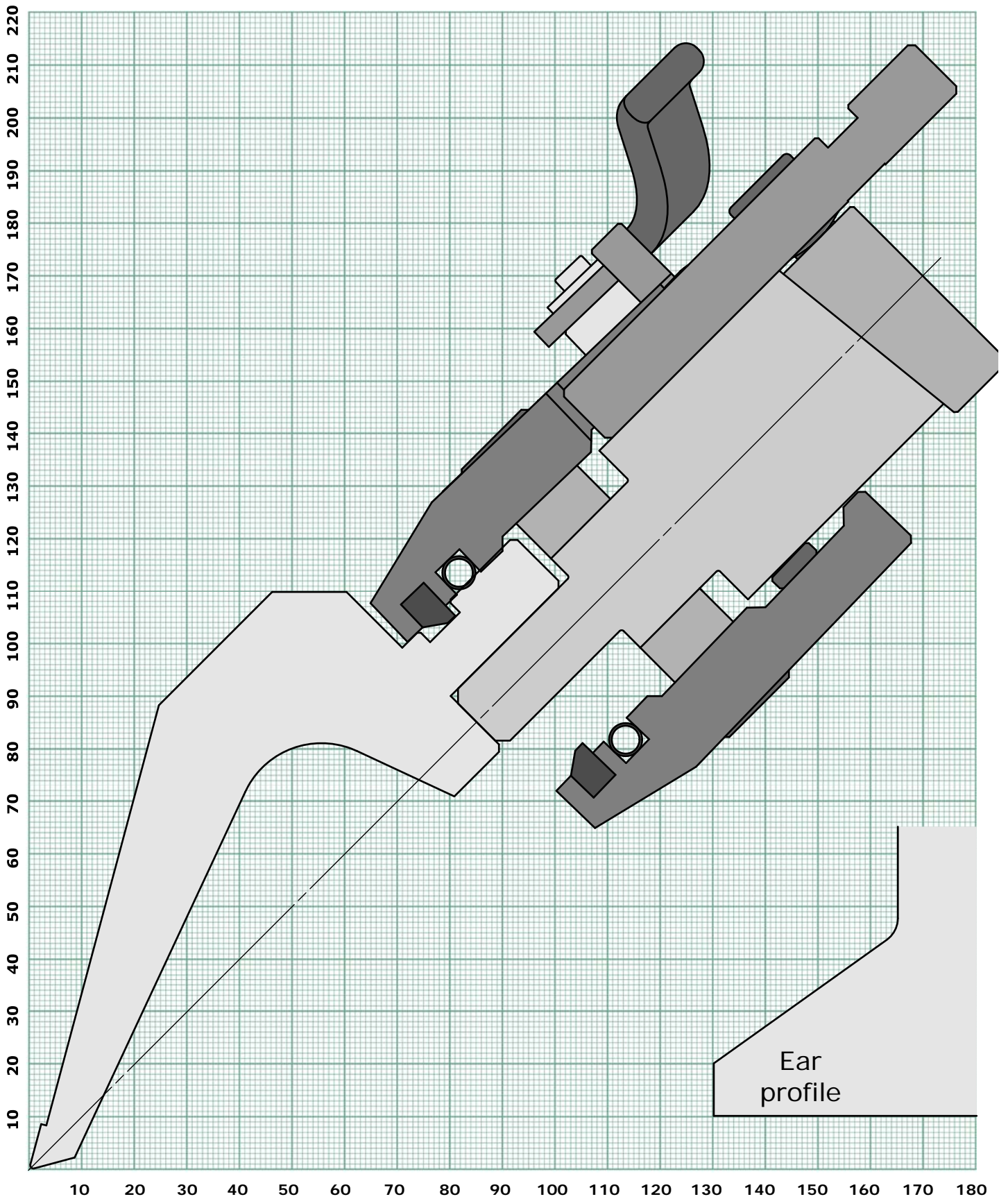

RETURN BEND LIMIT GRAPH
PUNCH 803

 Back to index

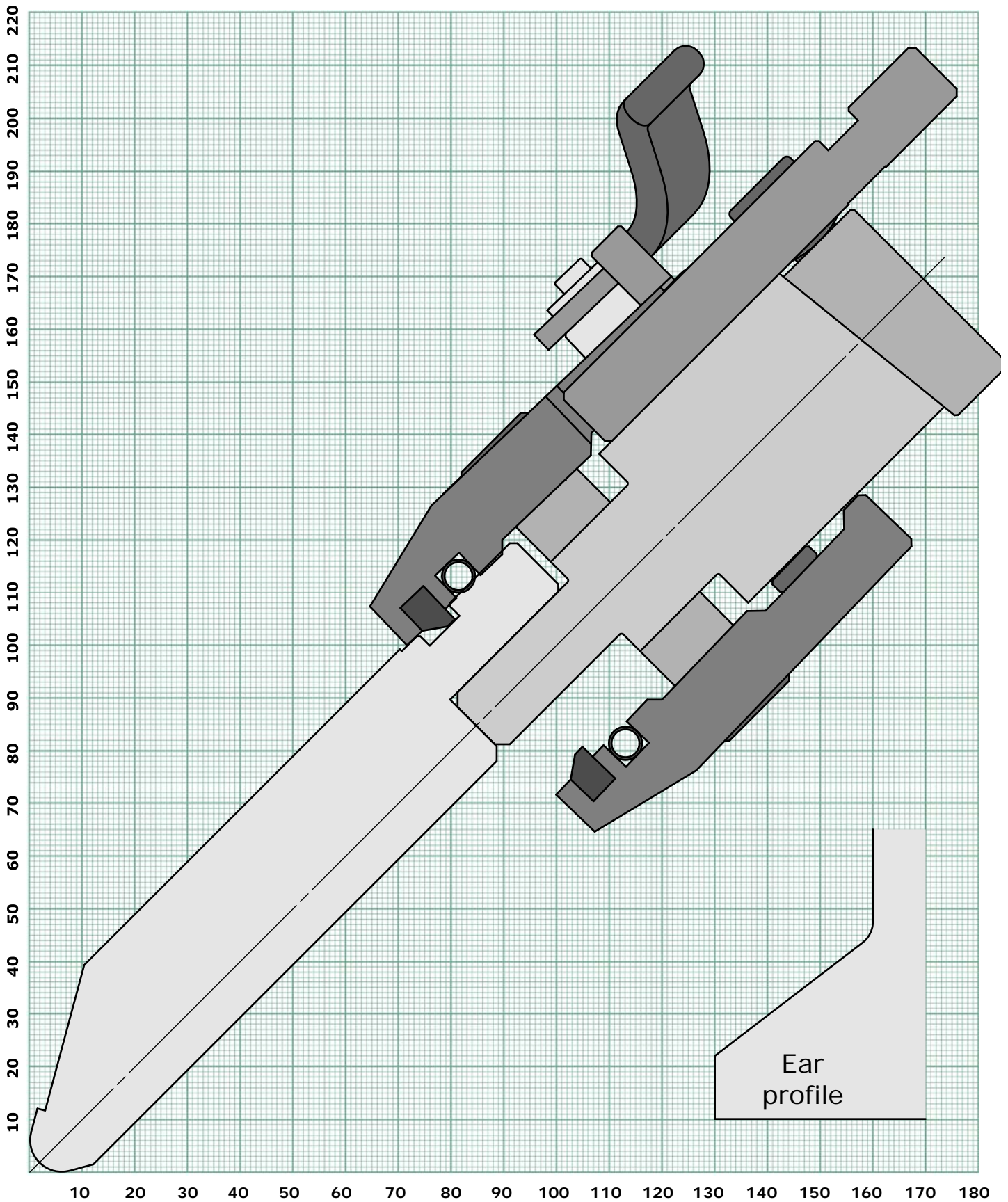

RETURN BEND LIMIT GRAPH
PUNCH 847

← Back to index

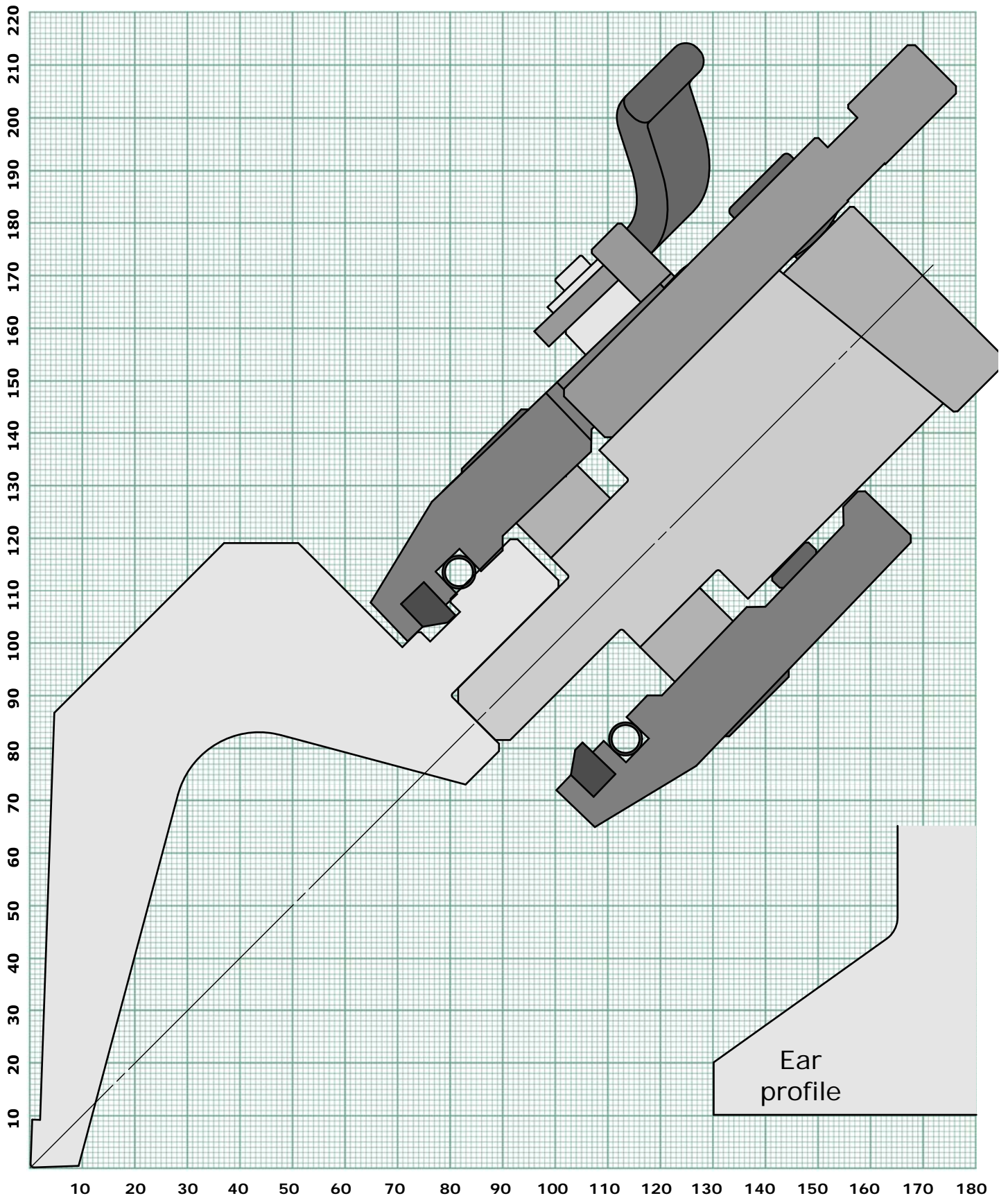

RETURN BEND LIMIT GRAPH
PUNCH 846

← Back to index

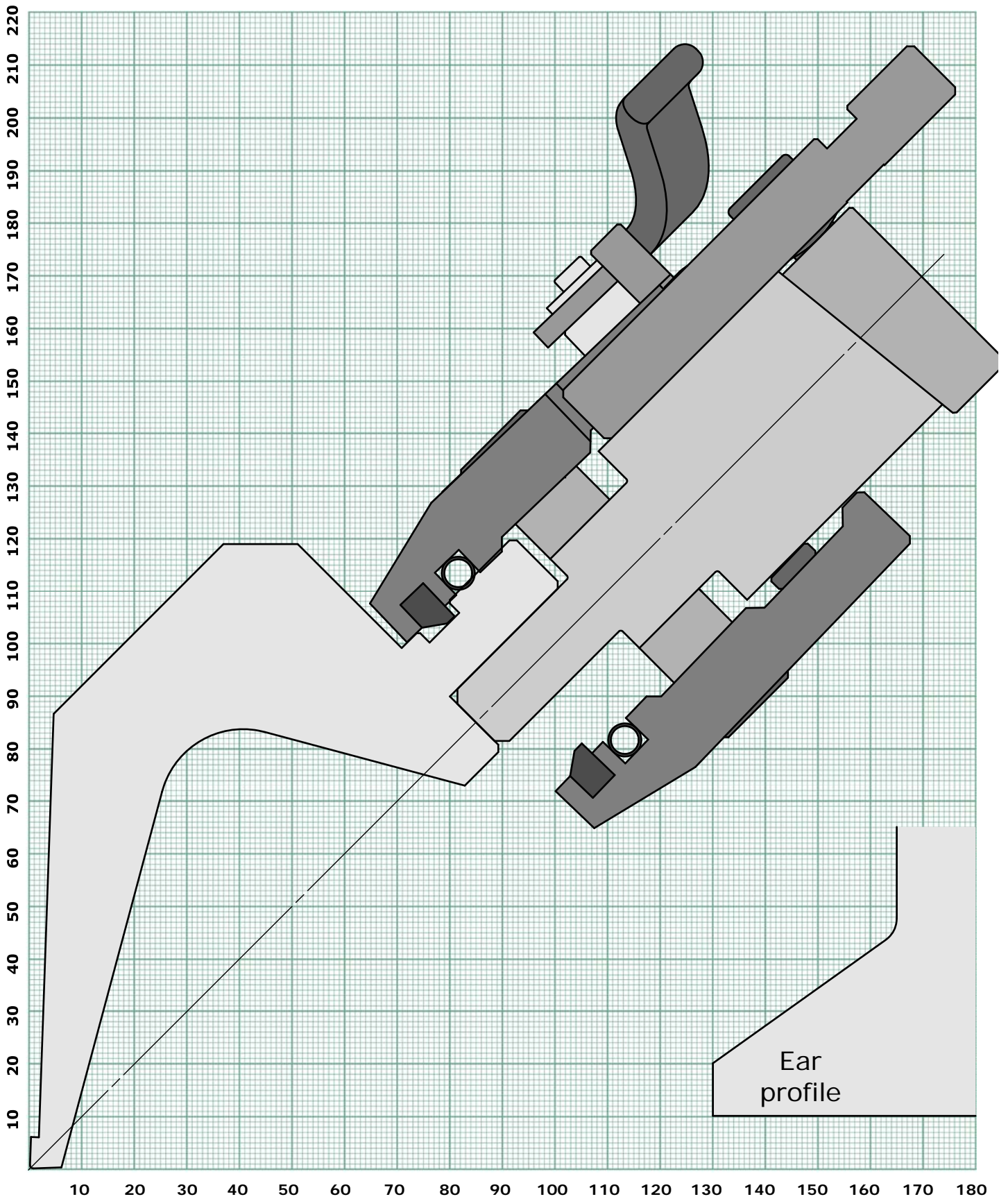

RETURN BEND LIMIT GRAPH
PUNCH 704

[← Back to index](#)

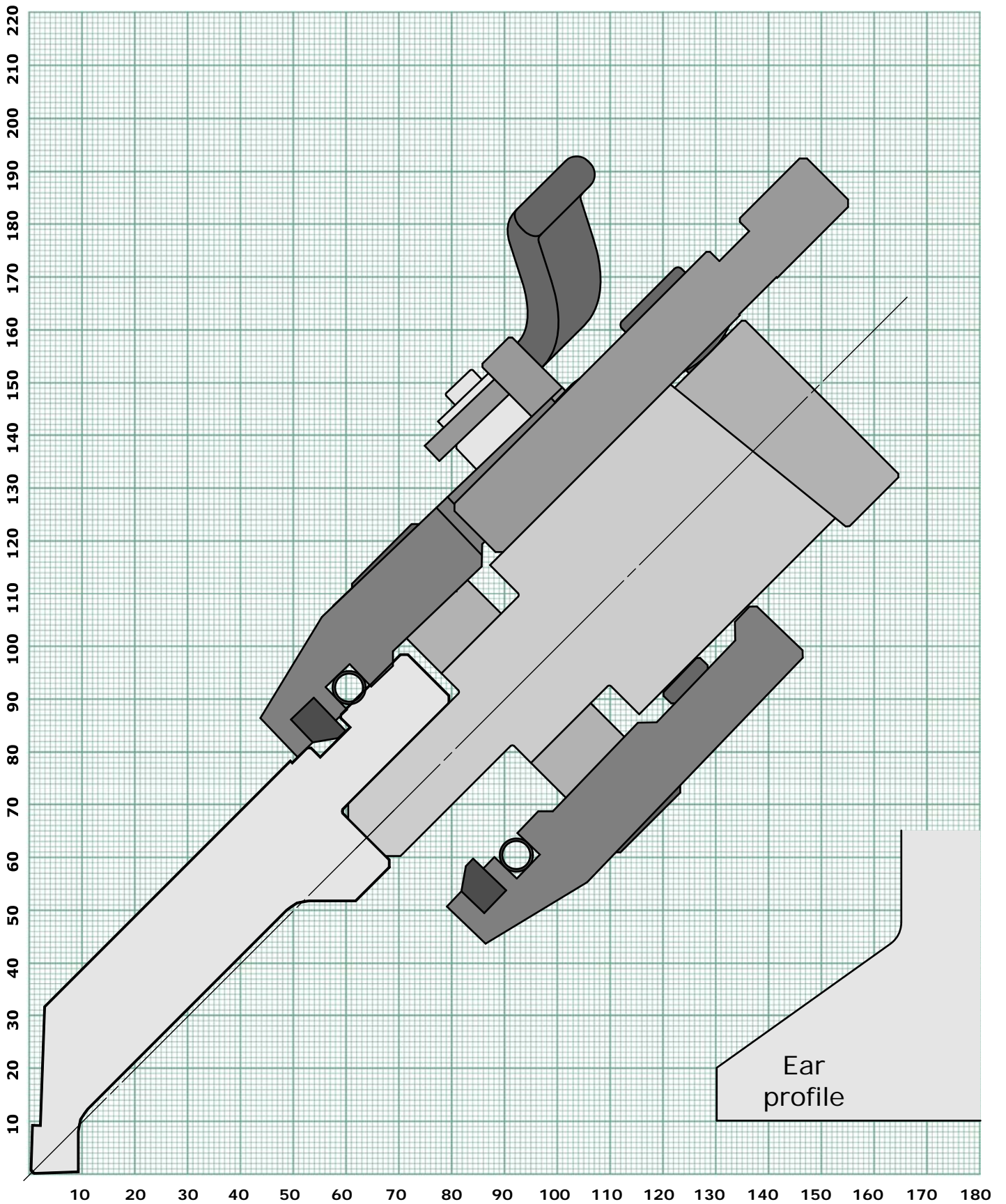

RETURN BEND LIMIT GRAPH
PUNCH 717

[← Back to index](#)

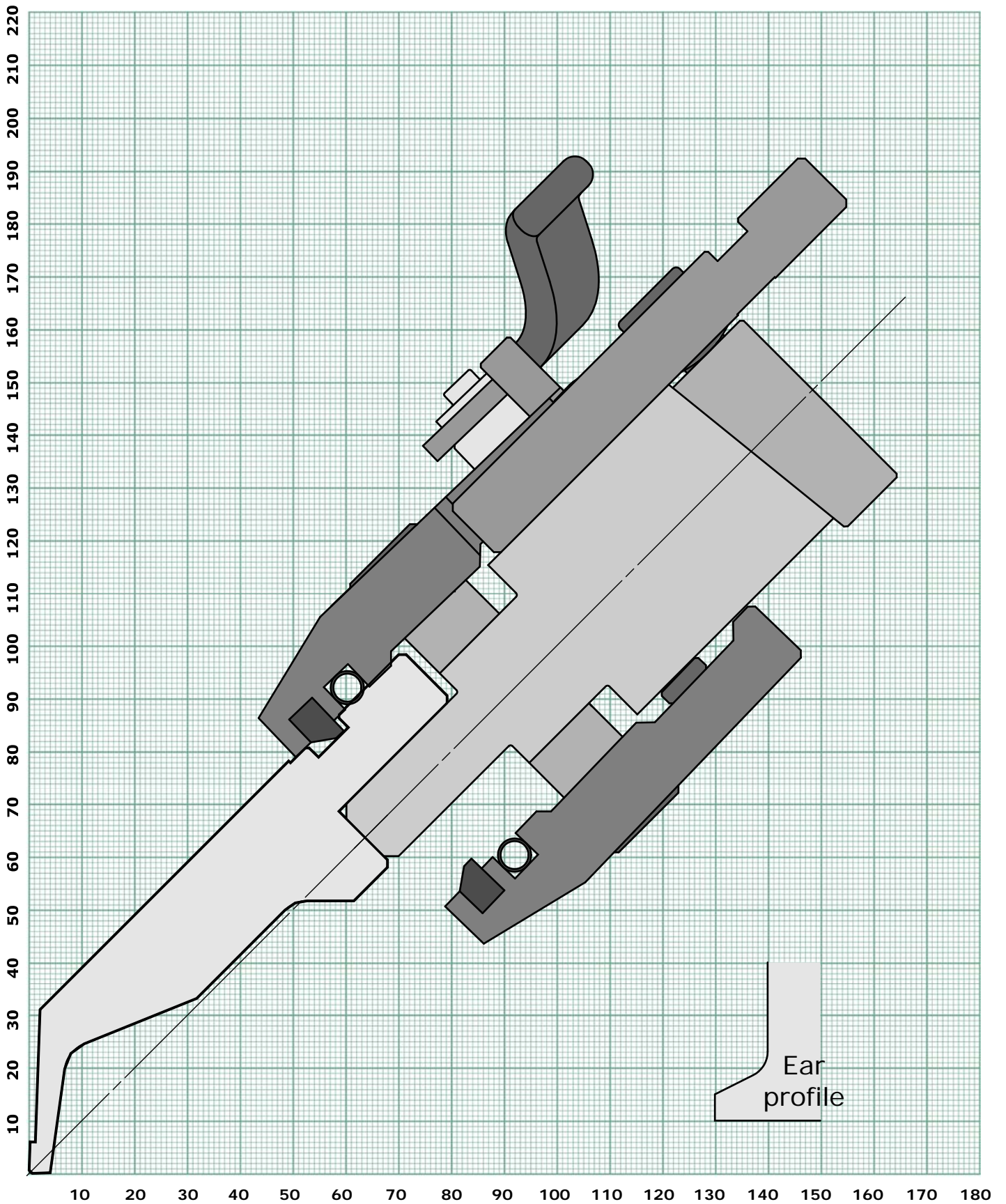

RETURN BEND LIMIT GRAPH
PUNCH 747

← Back to
index

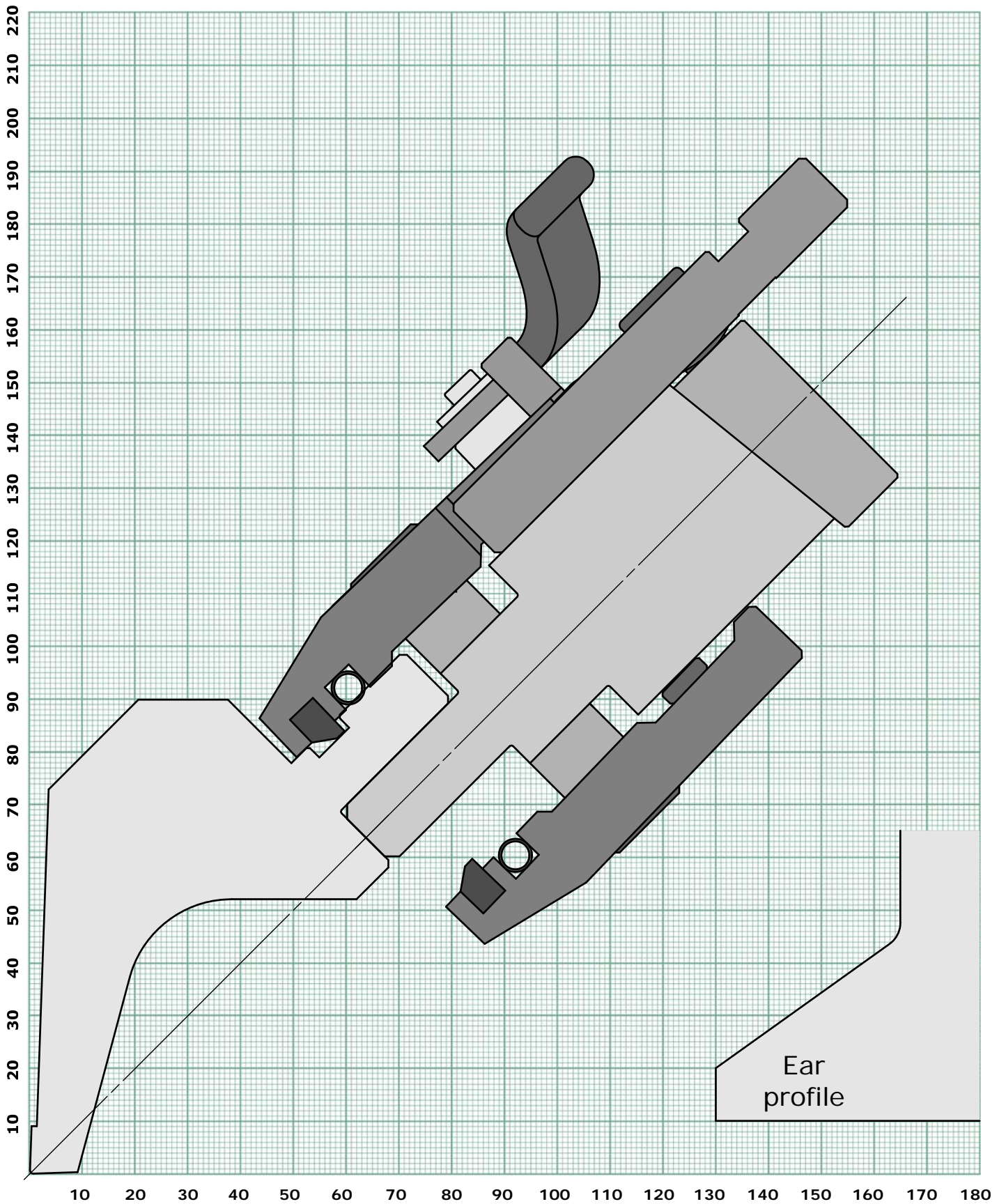

RETURN BEND LIMIT GRAPH
PUNCH 746

← Back to index

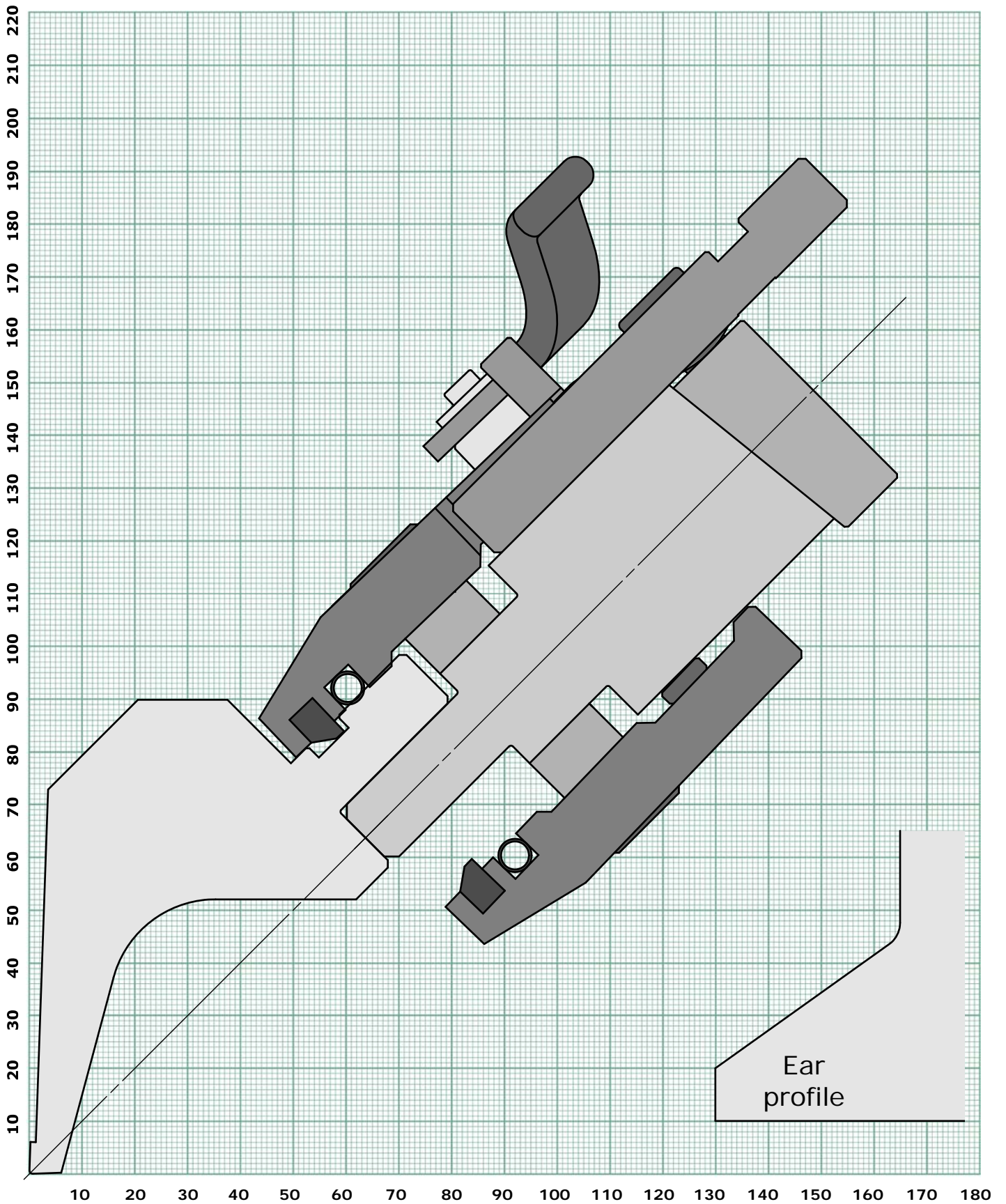

RETURN BEND LIMIT GRAPH
PUNCH 720

[← Back to index](#)

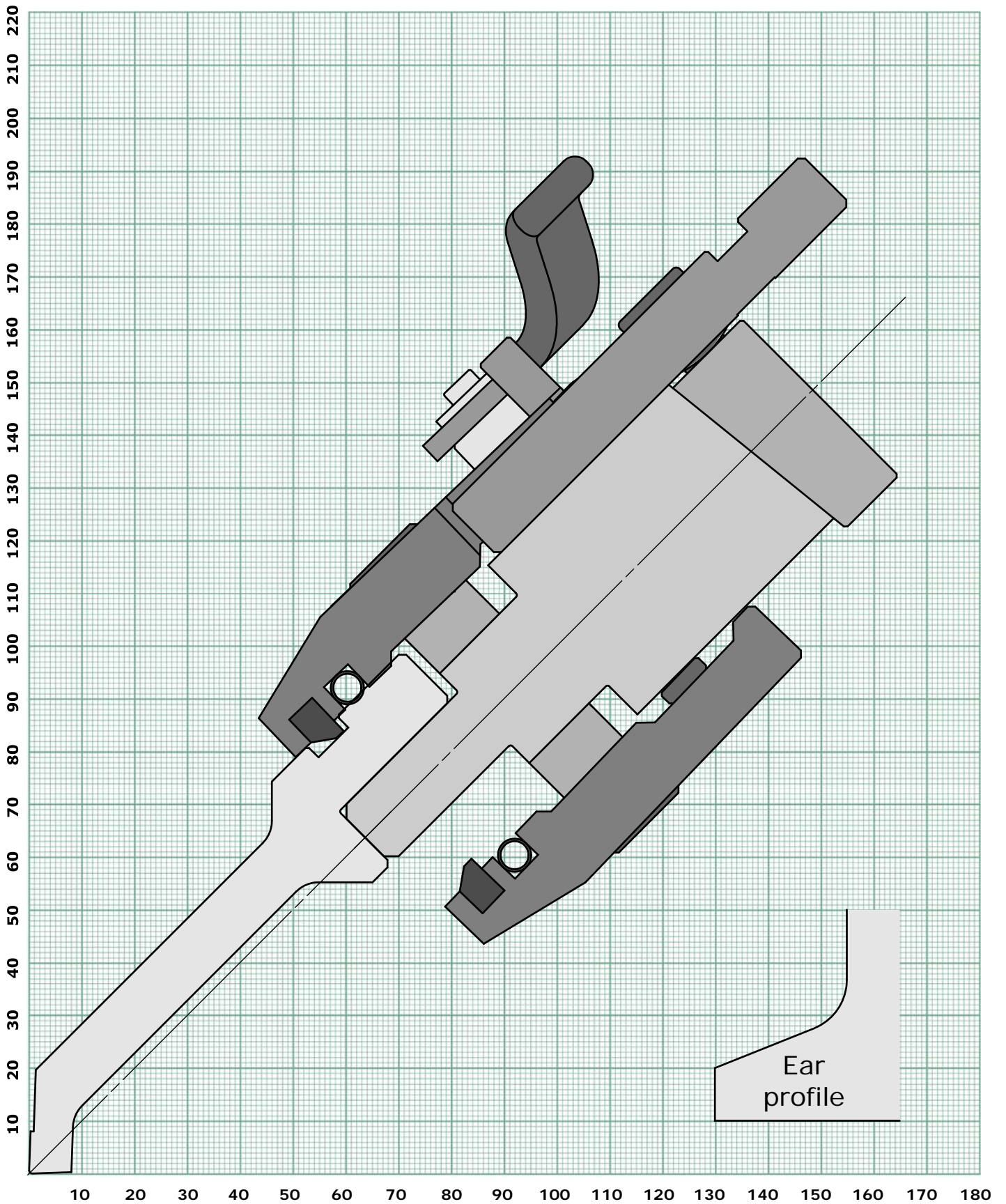

RETURN BEND LIMIT GRAPH
PUNCH 713

[← Back to index](#)

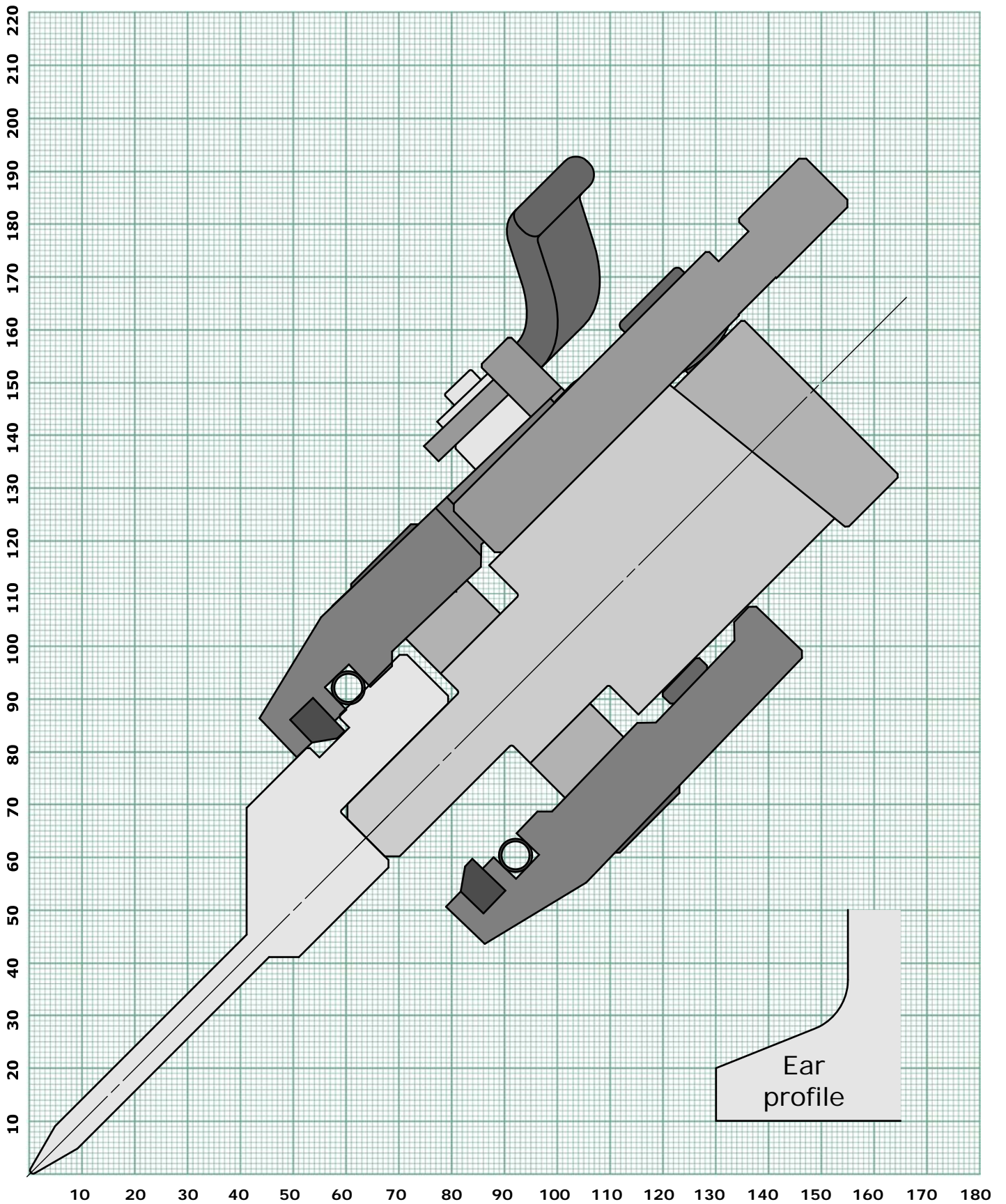

RETURN BEND LIMIT GRAPH
PUNCH 731-R0,6

[← Back to index](#)

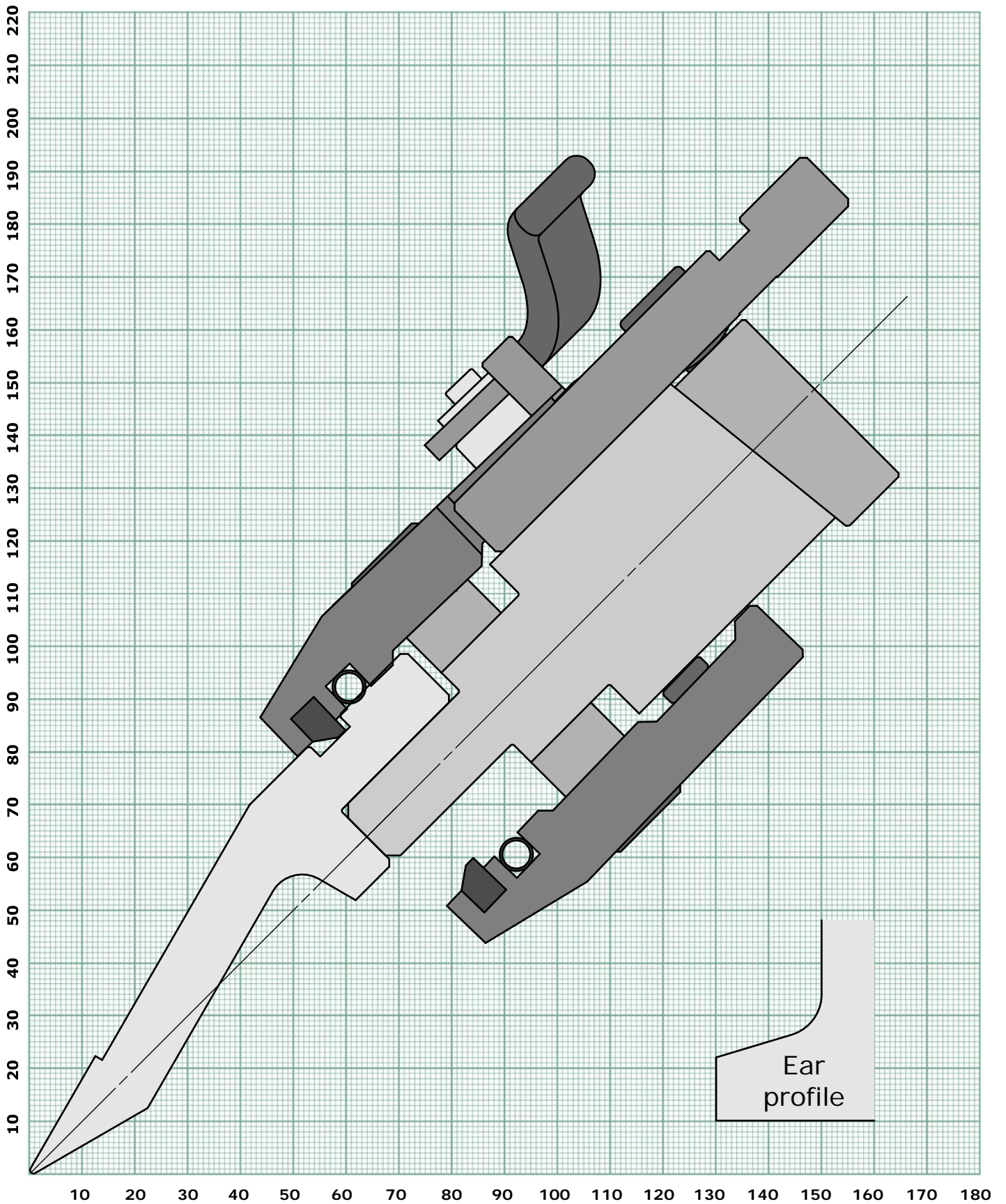

RETURN BEND LIMIT GRAPH
PUNCH 731-R3

[← Back to index](#)

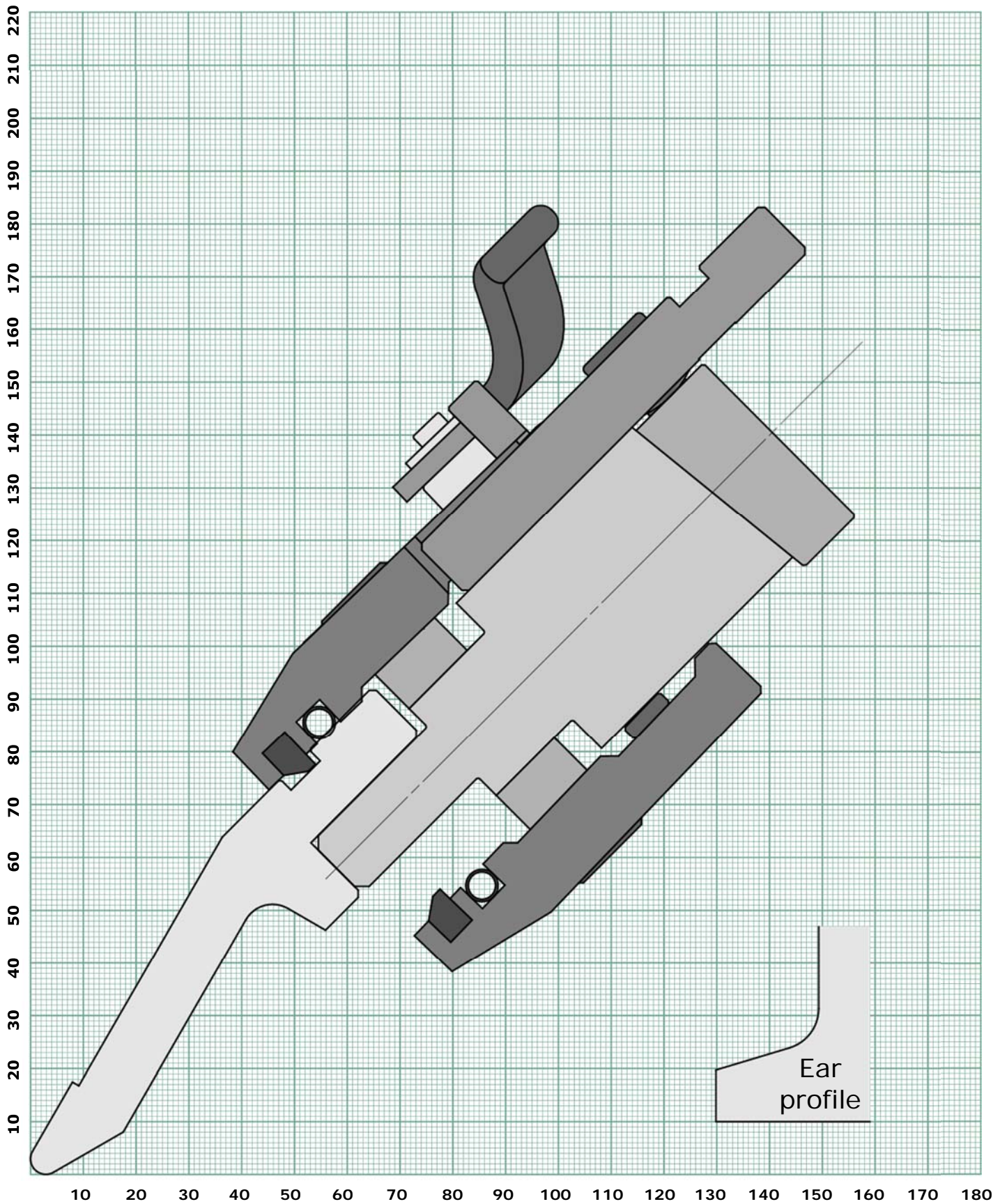

RETURN BEND LIMIT GRAPH
PUNCH 904

[← Back to index](#)

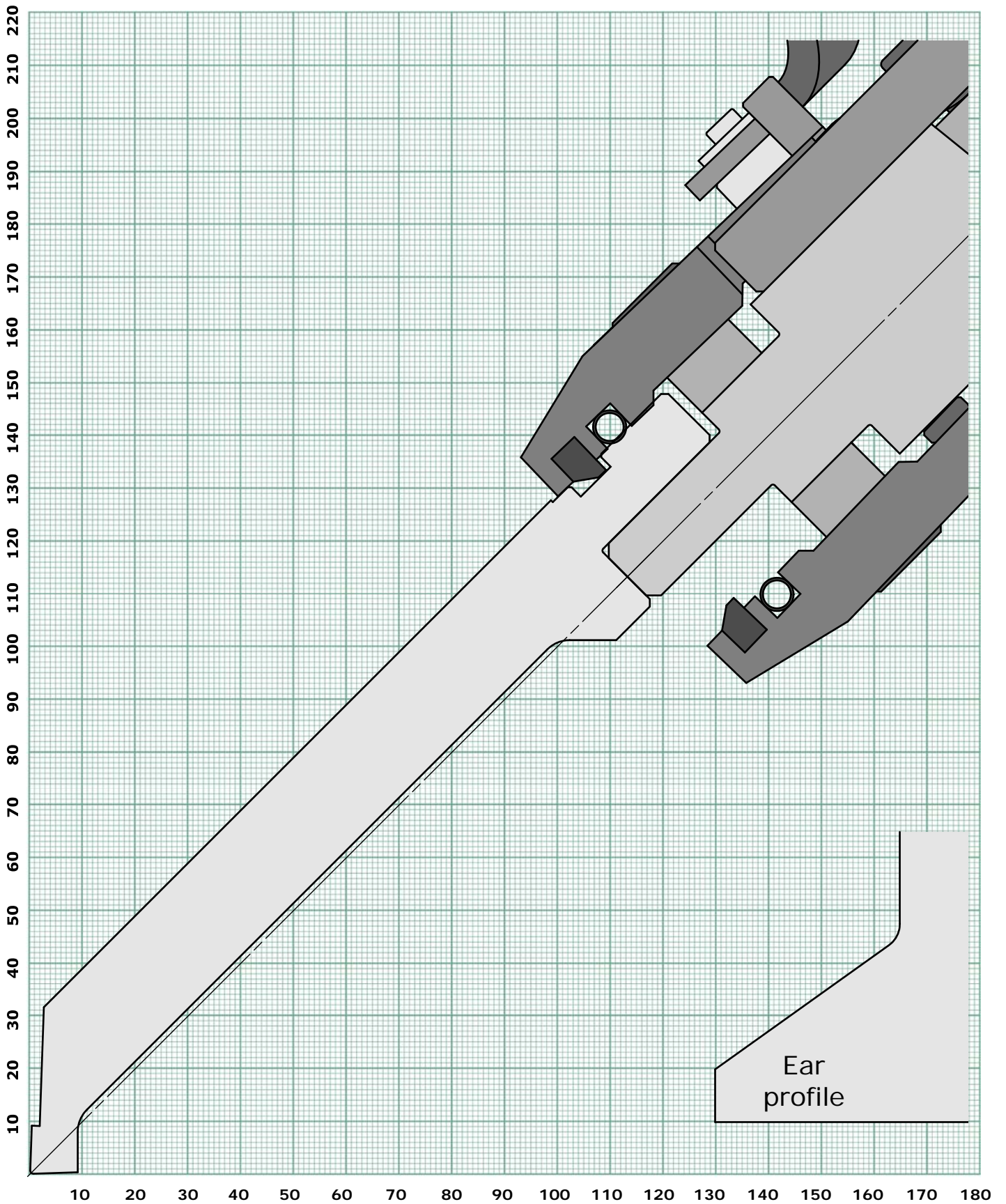

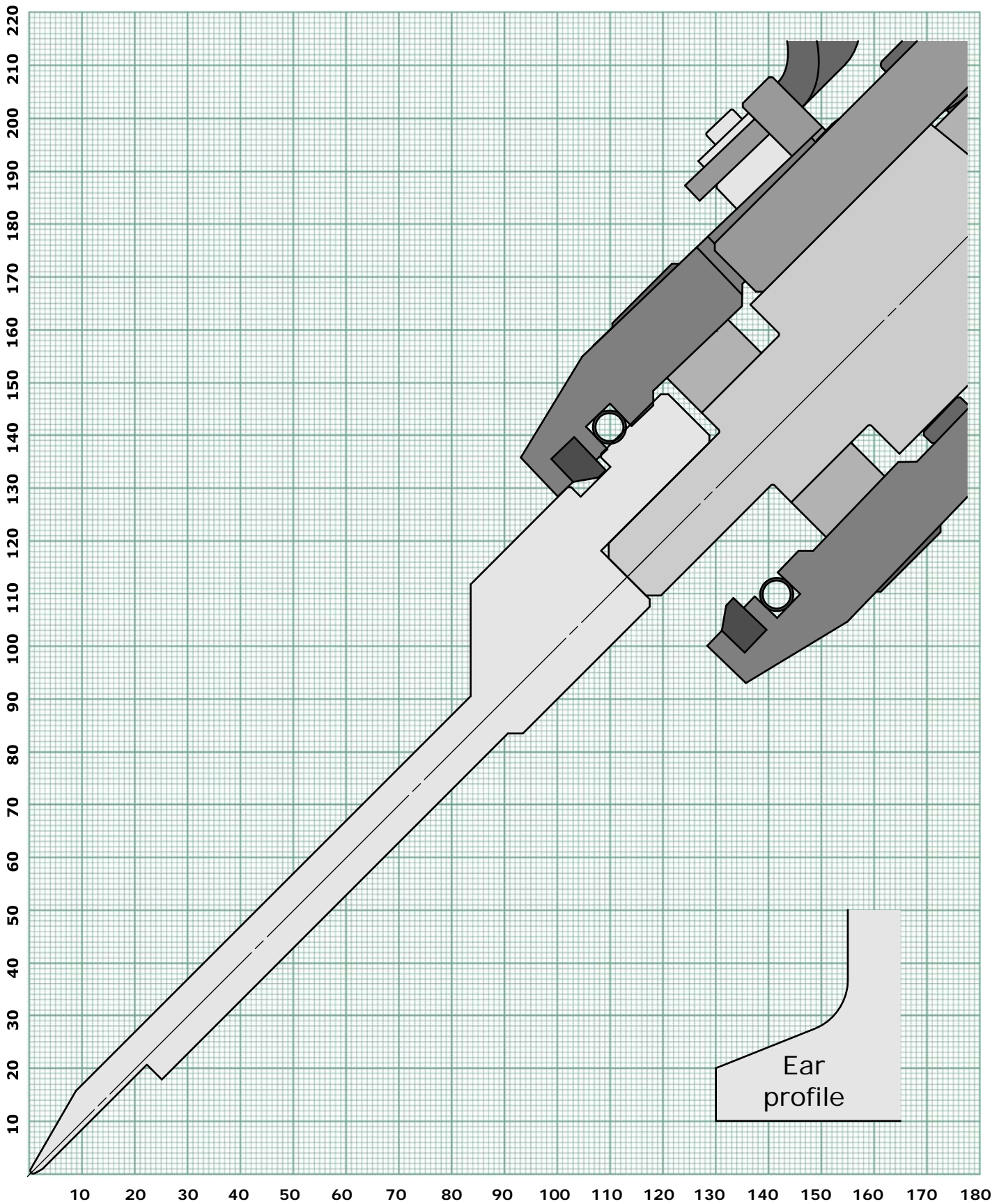

RETURN BEND LIMIT GRAPH
PUNCH 947

[← Back to index](#)

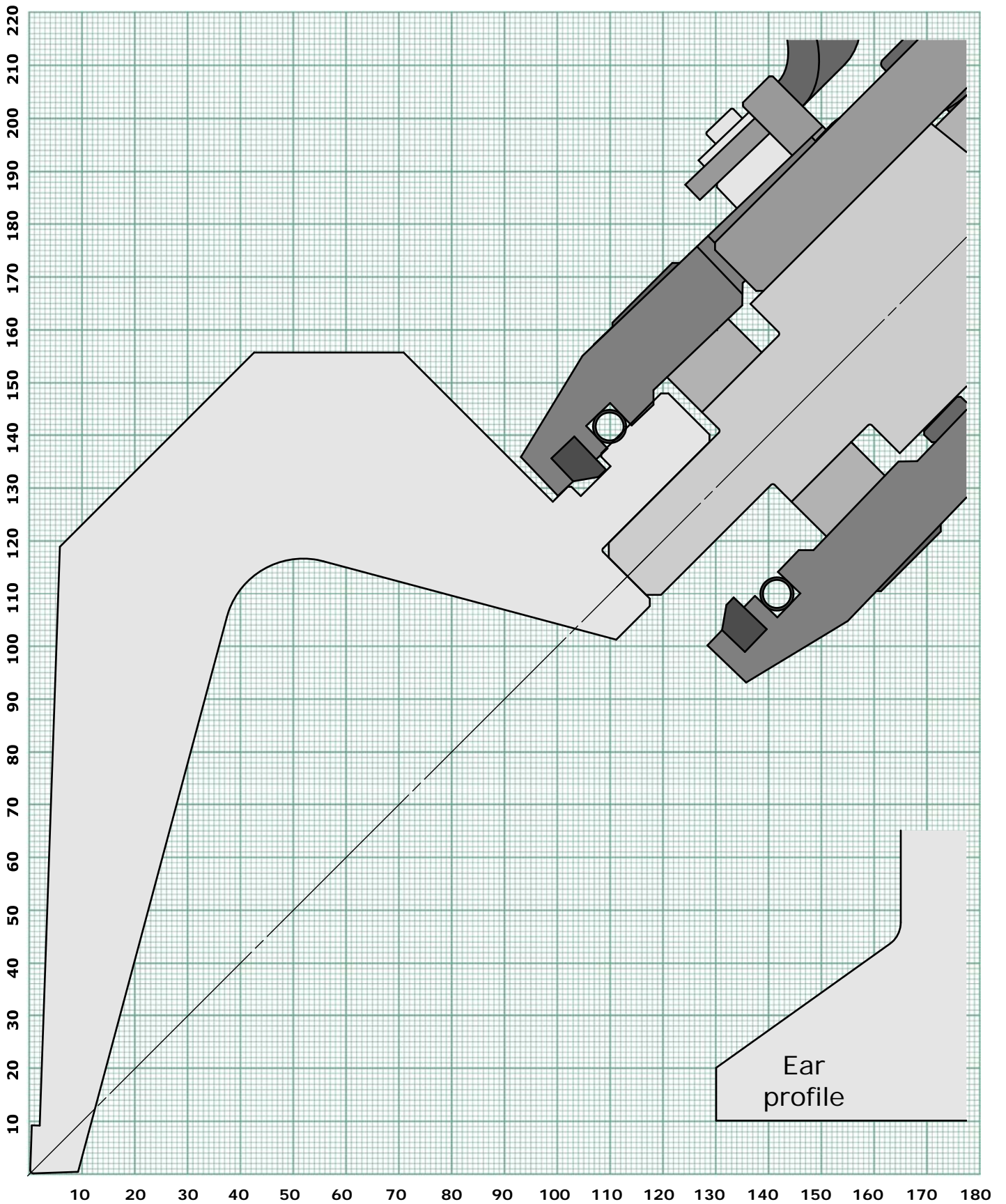

RETURN BEND LIMIT GRAPH
PUNCH 604

← Back to
index

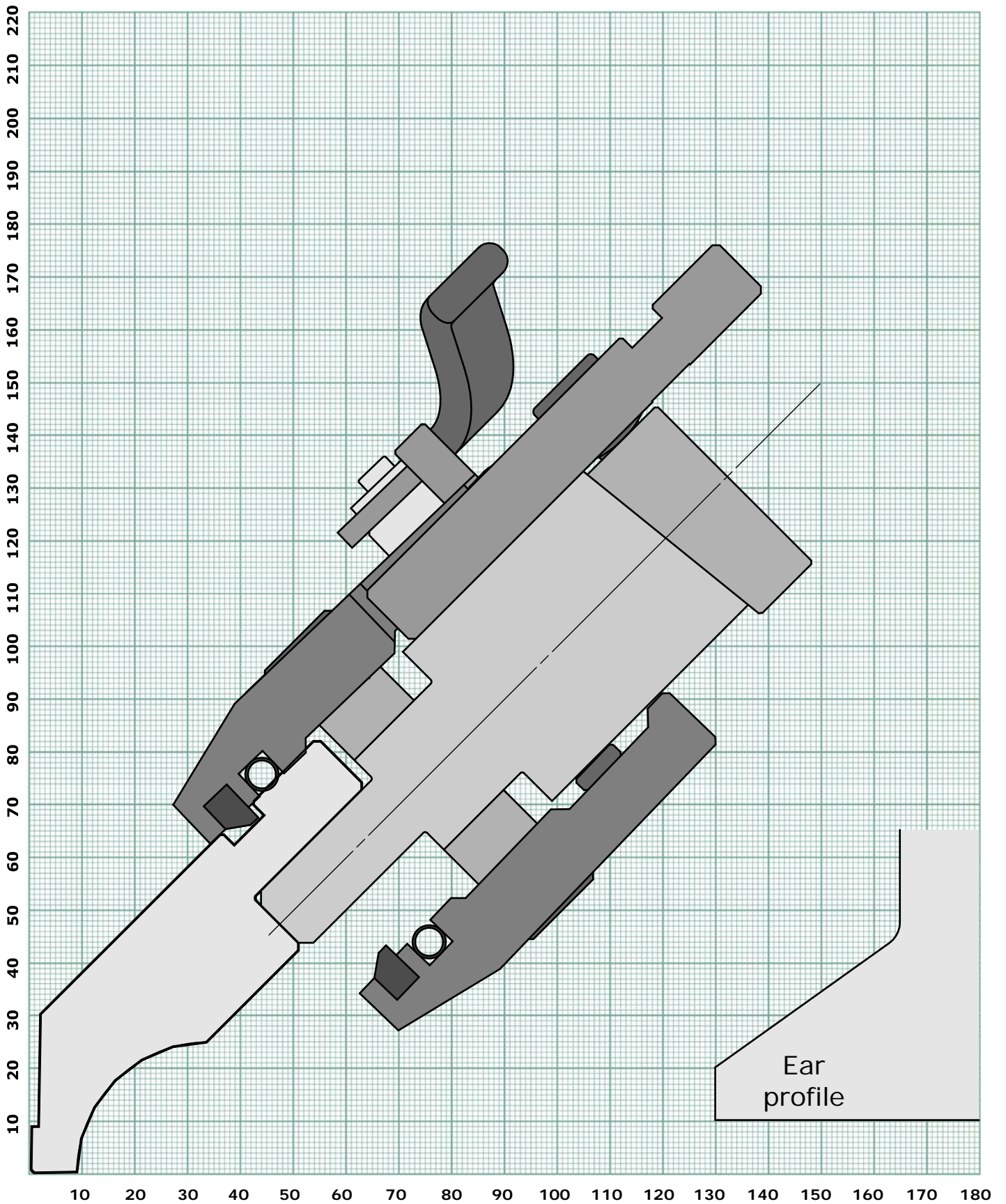

RETURN BEND LIMIT GRAPH
PUNCH 603

← Back to index

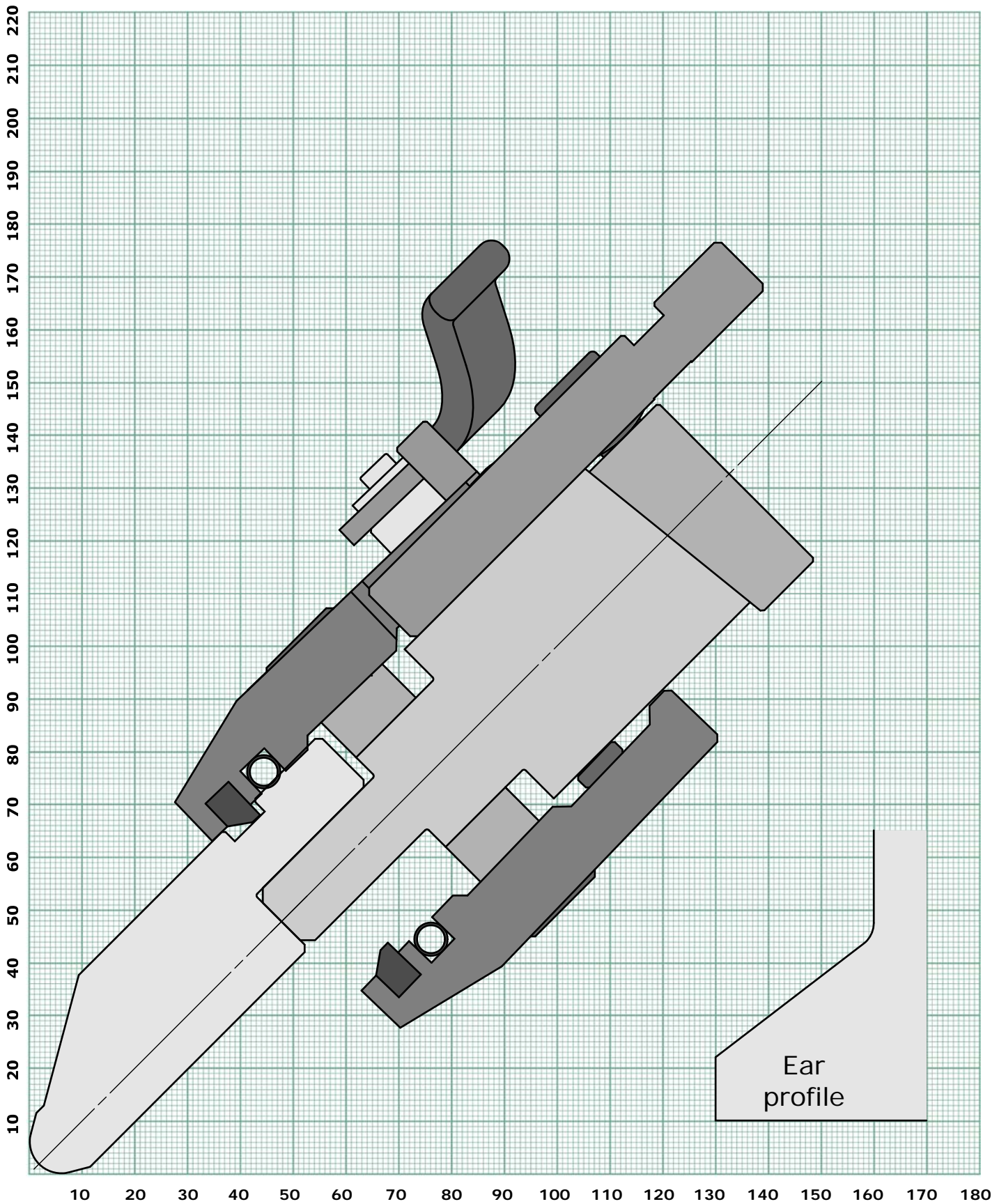

RETURN BEND LIMIT GRAPH
PUNCH 617

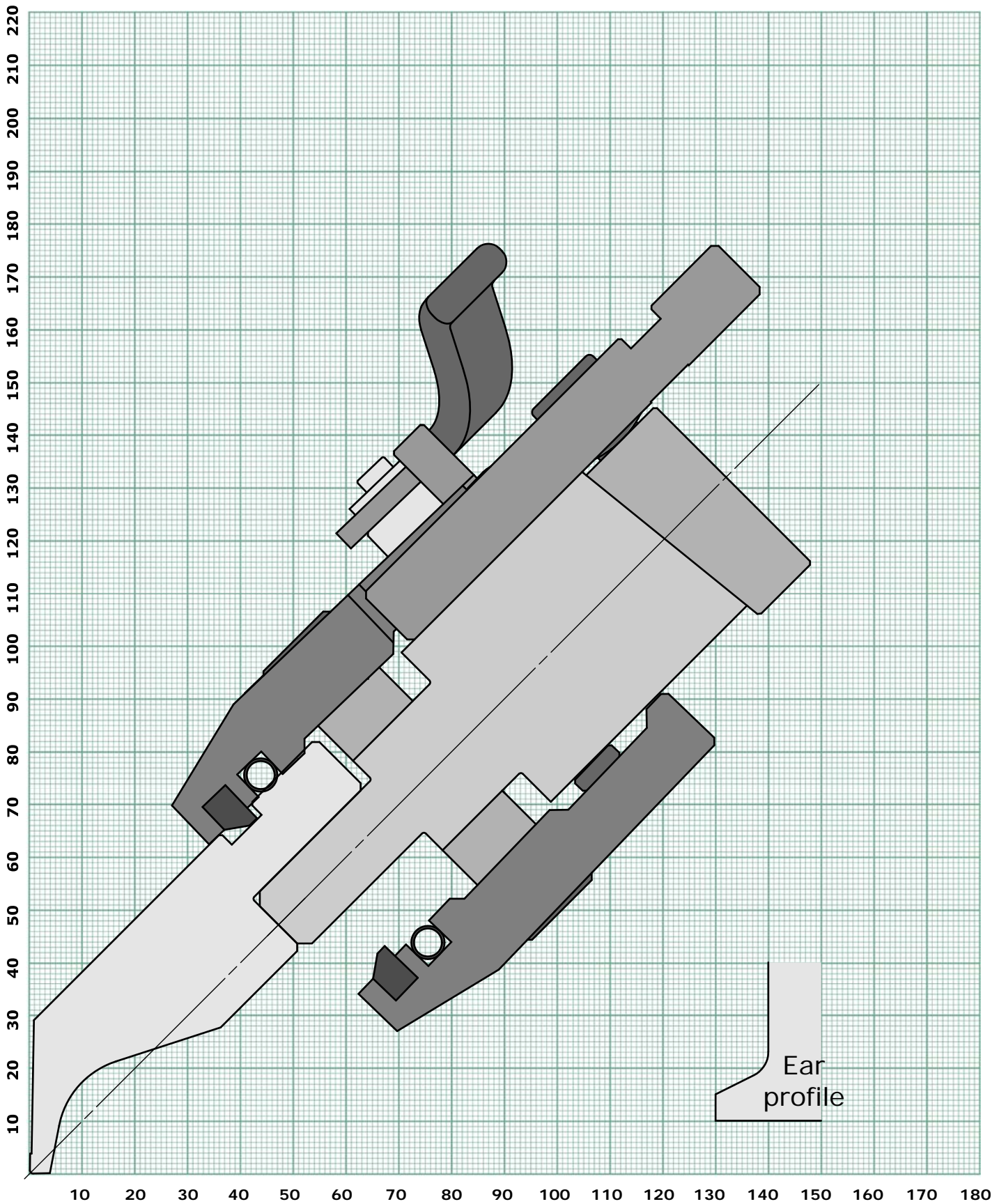

RETURN BEND LIMIT GRAPH
PUNCH 631

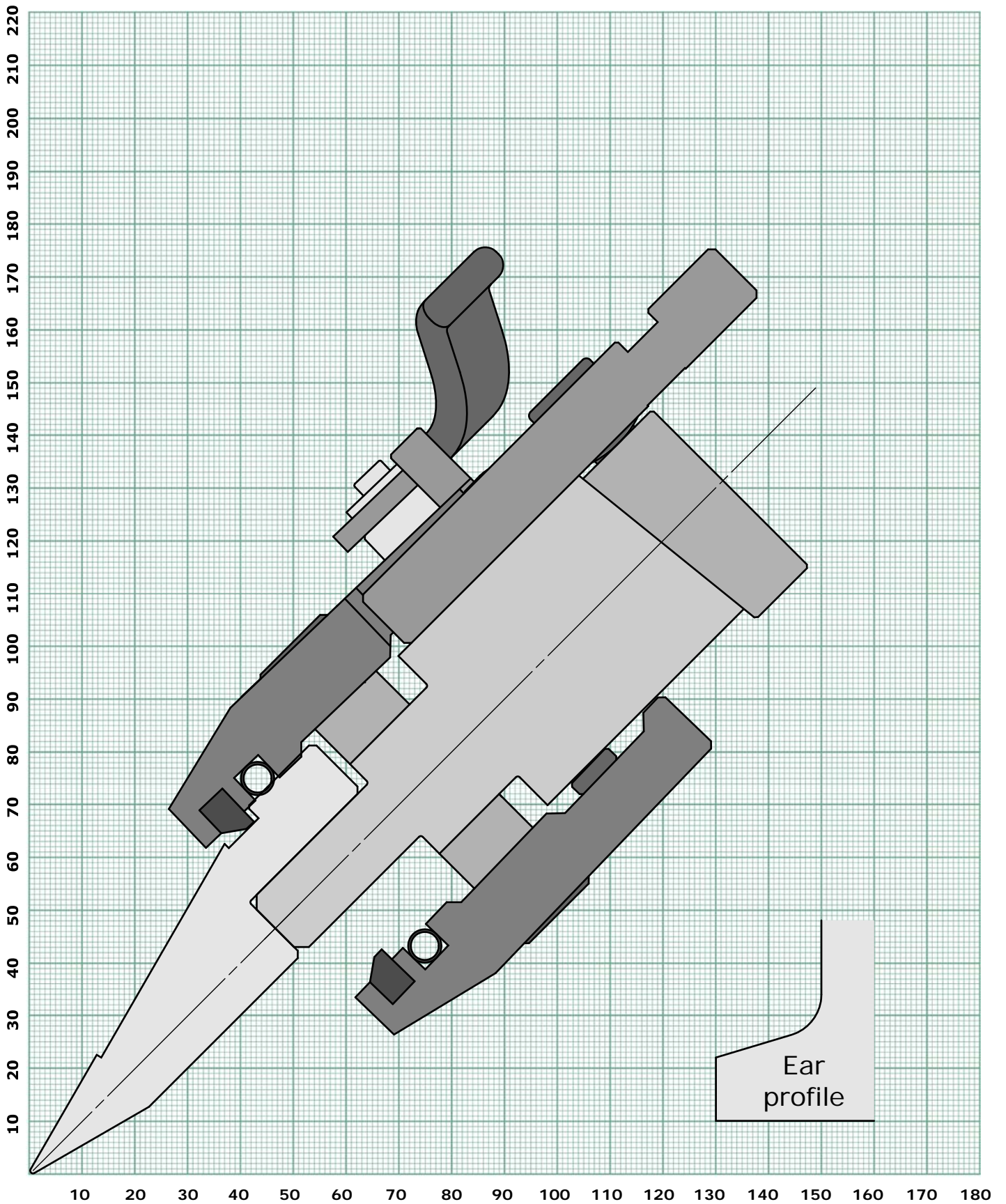

RETURN BEND LIMIT GRAPH
PUNCH 640

← Back to index

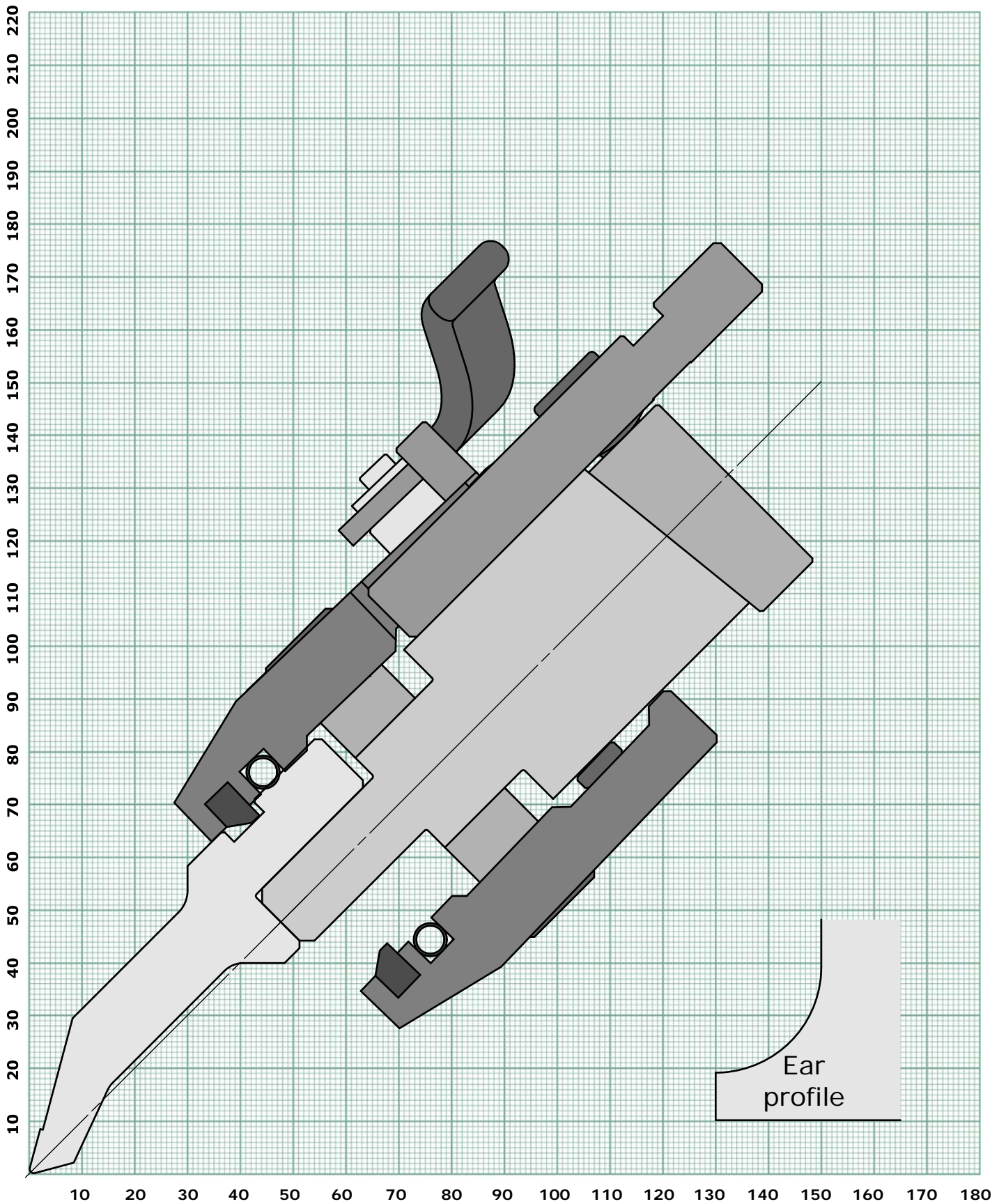

R7 Ruller with EH015 Holder

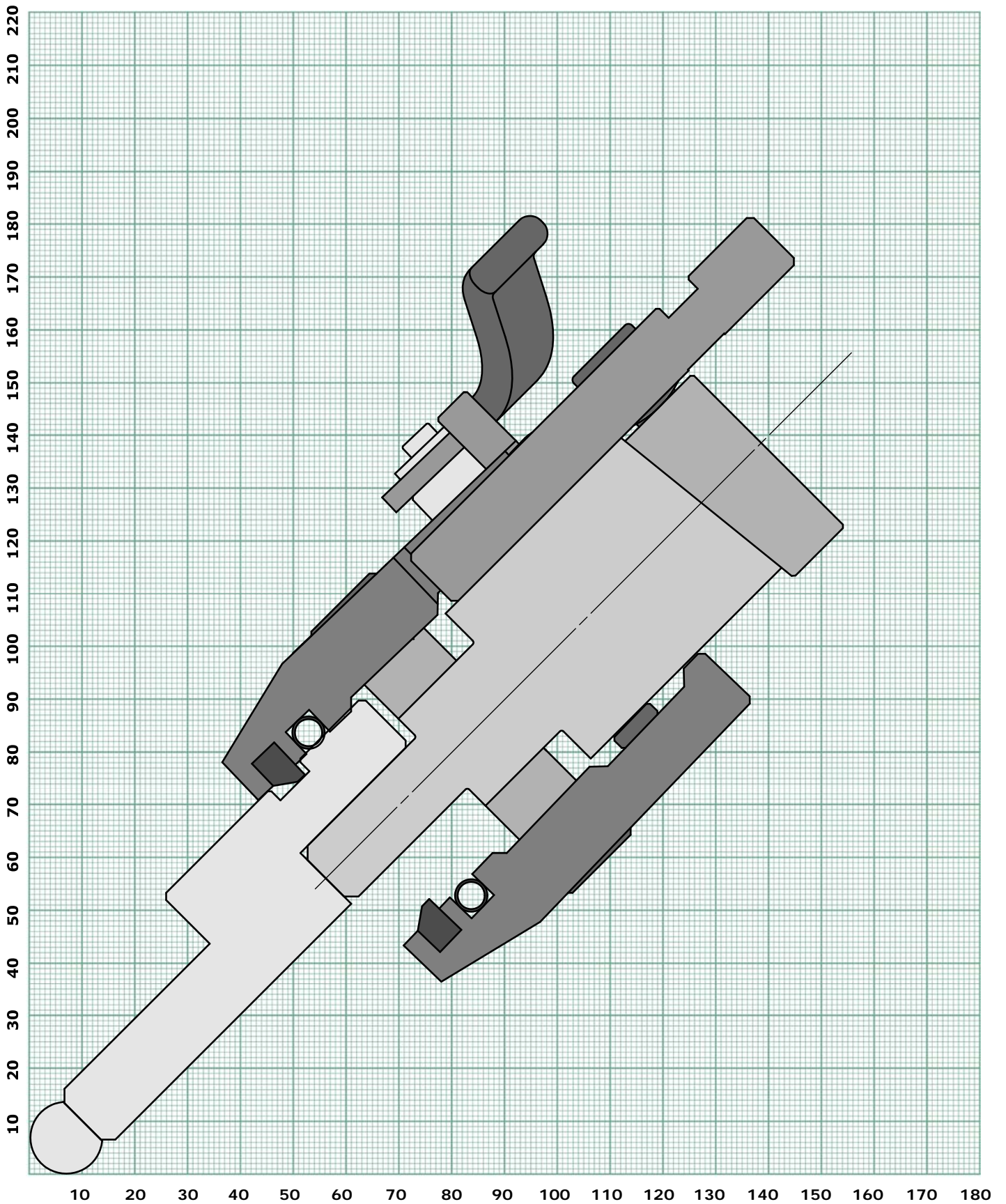

R8 Ruller with EH015 Holder

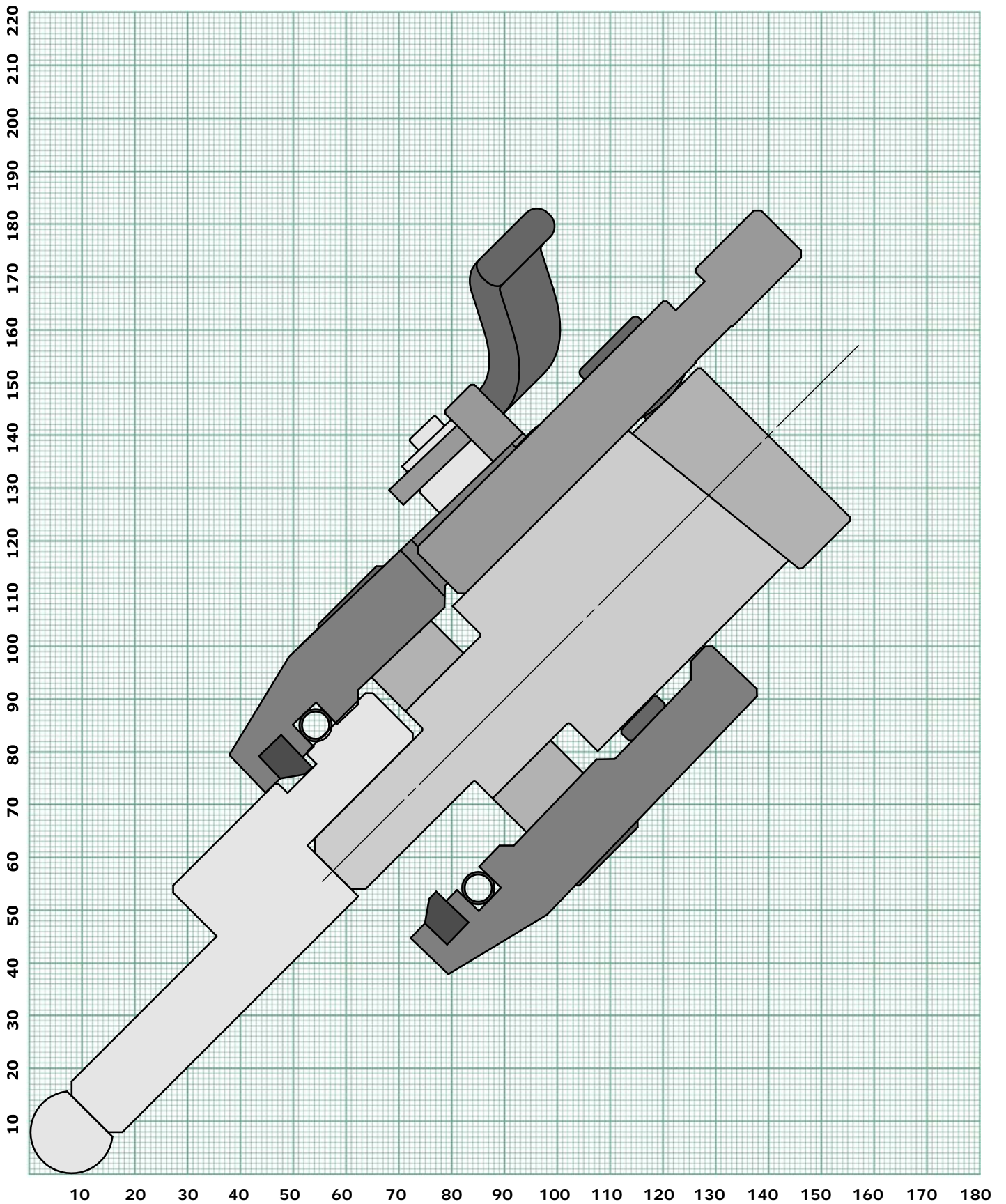

R9 Ruller with EH015 Holder

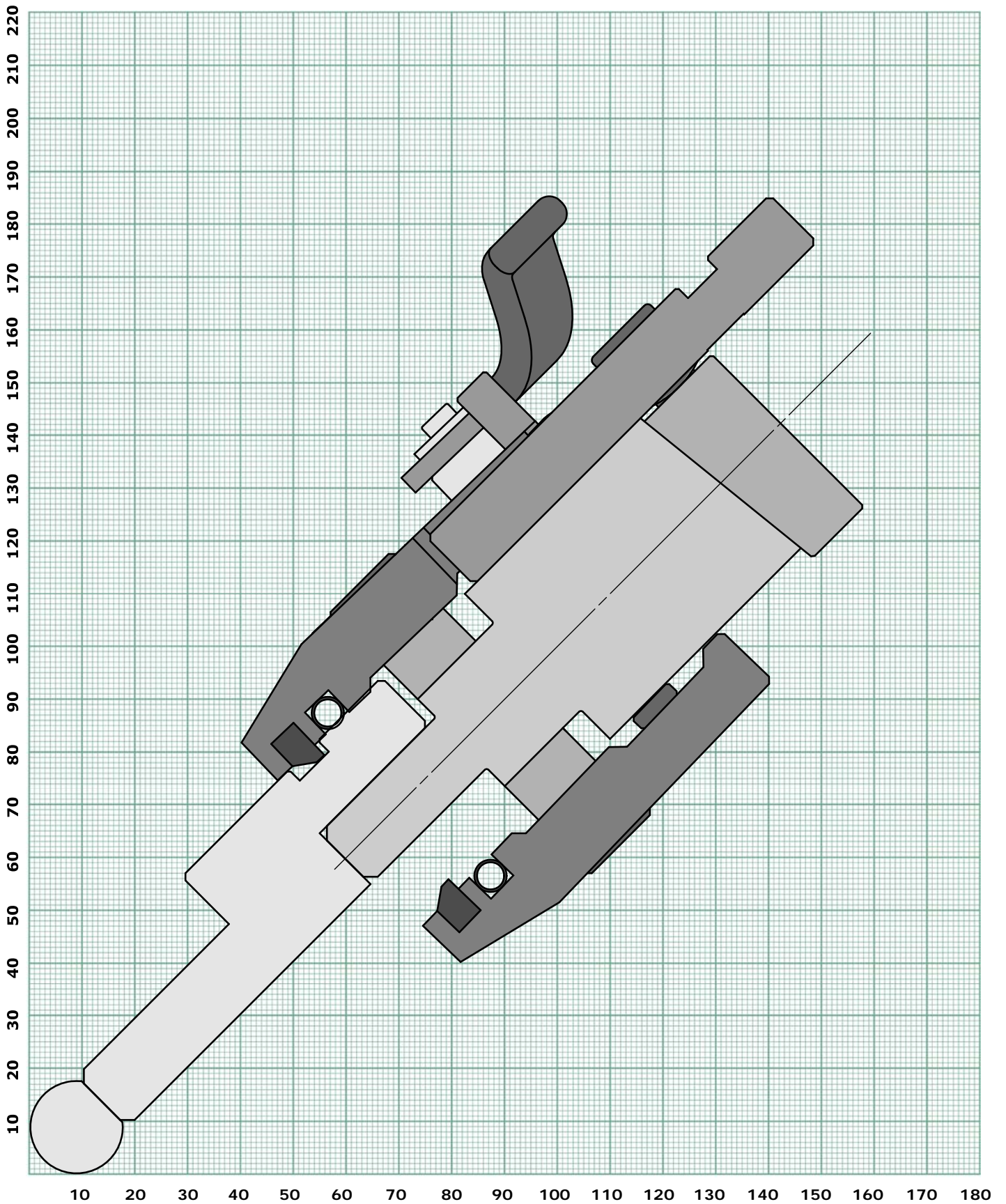

R10 Ruller with EH015 Holder

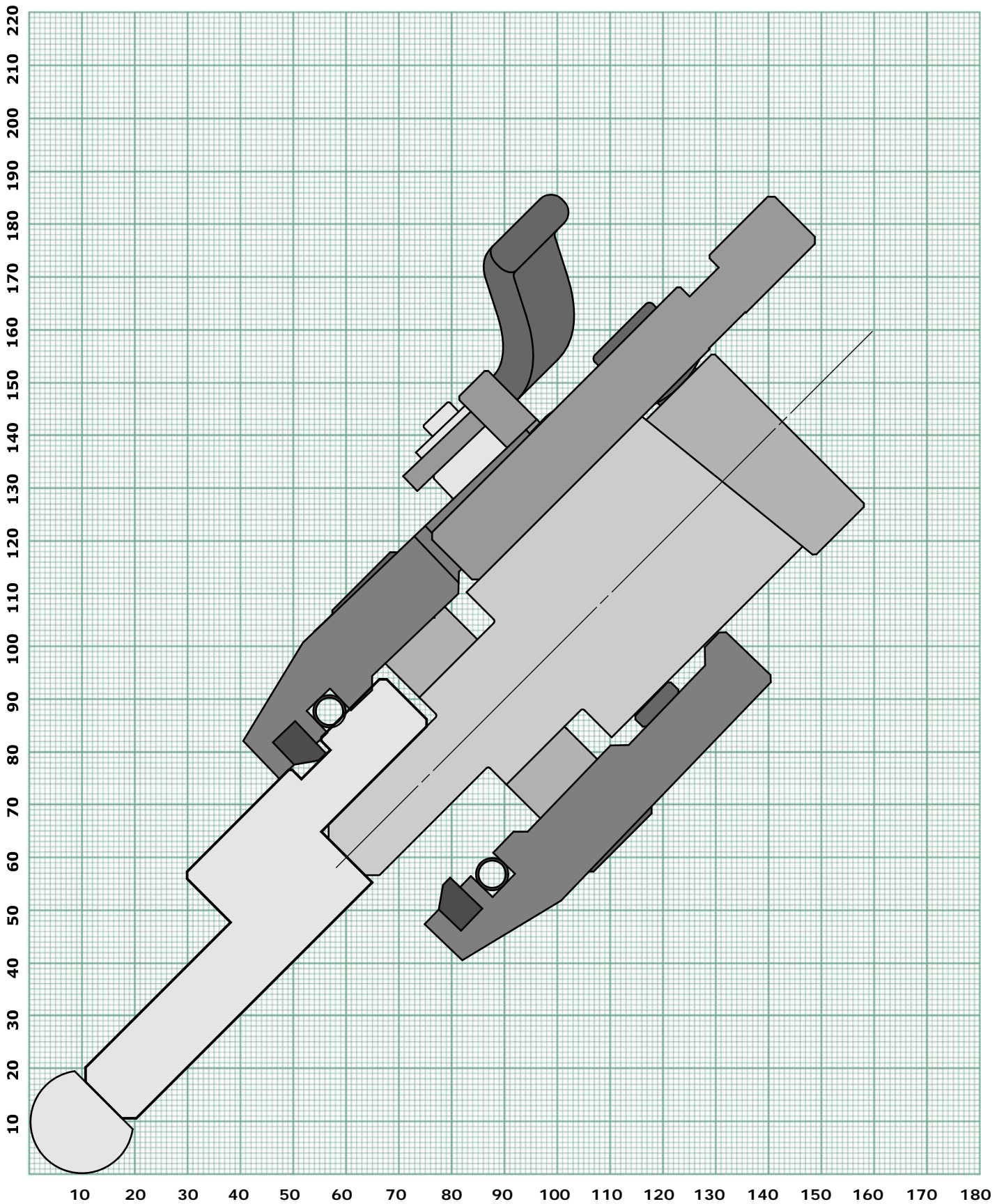

R11 Ruller with EH015 Holder

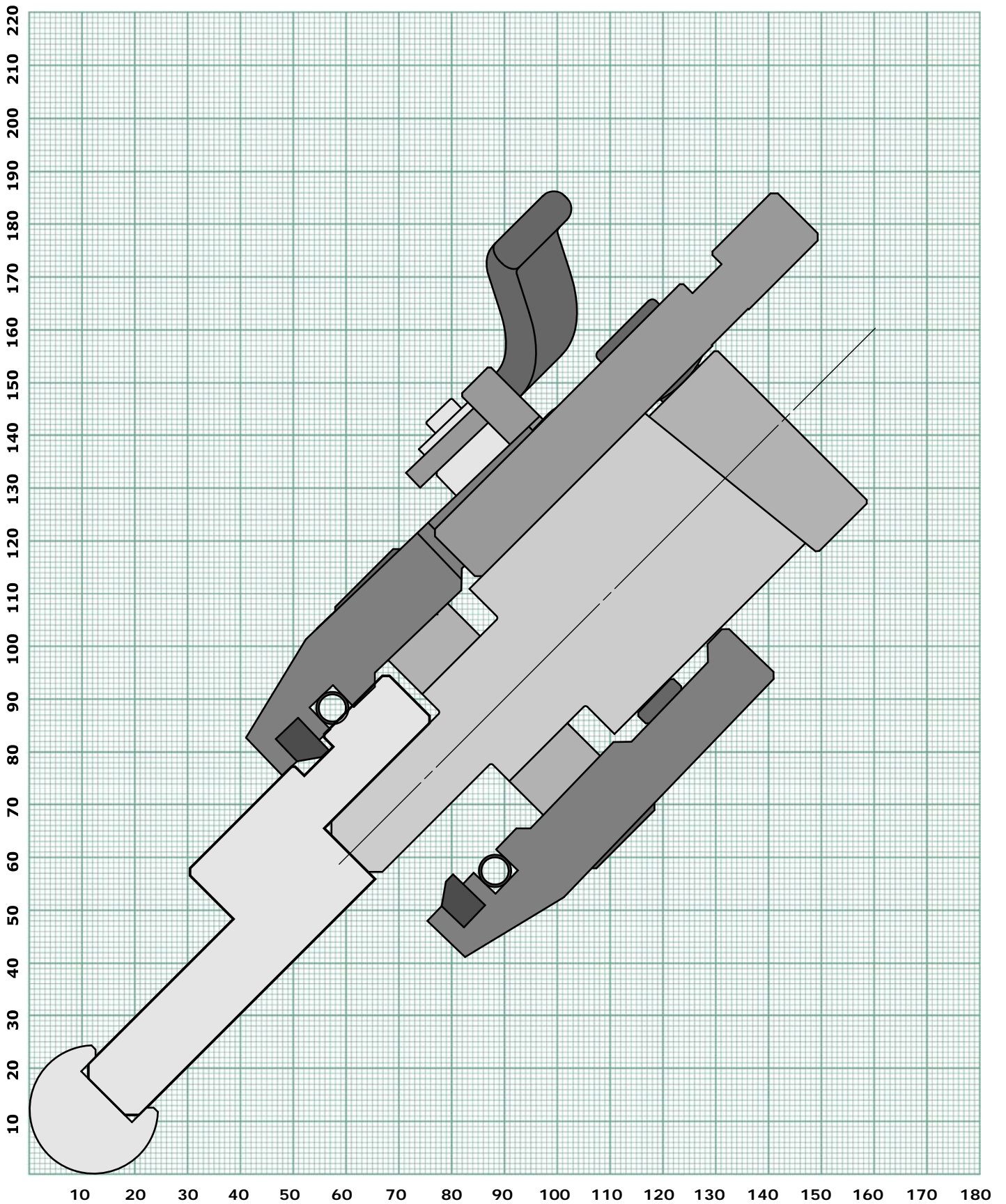

R12,5 Ruller with EH015 Holder

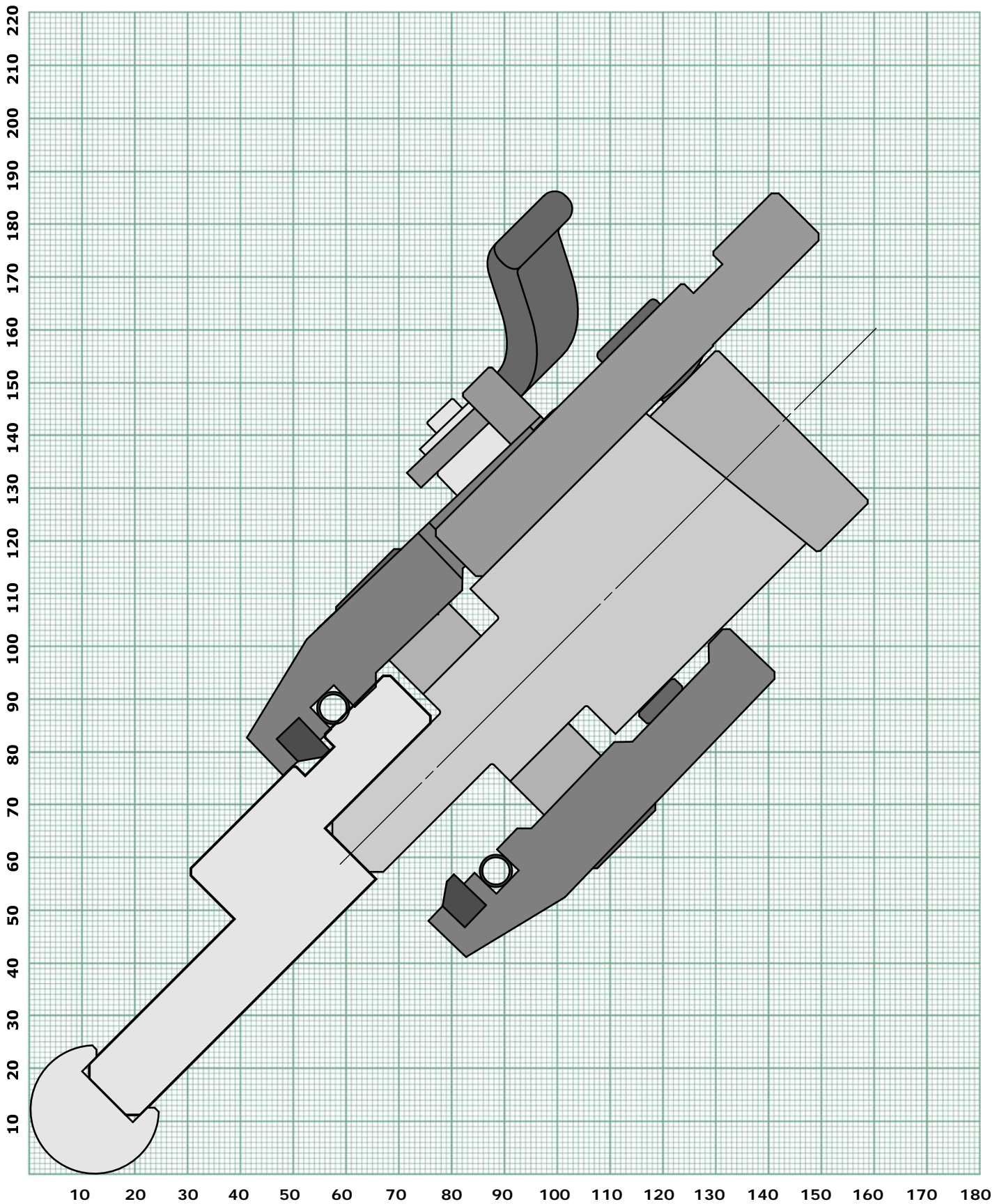

R14 Ruller with EH015 Holder

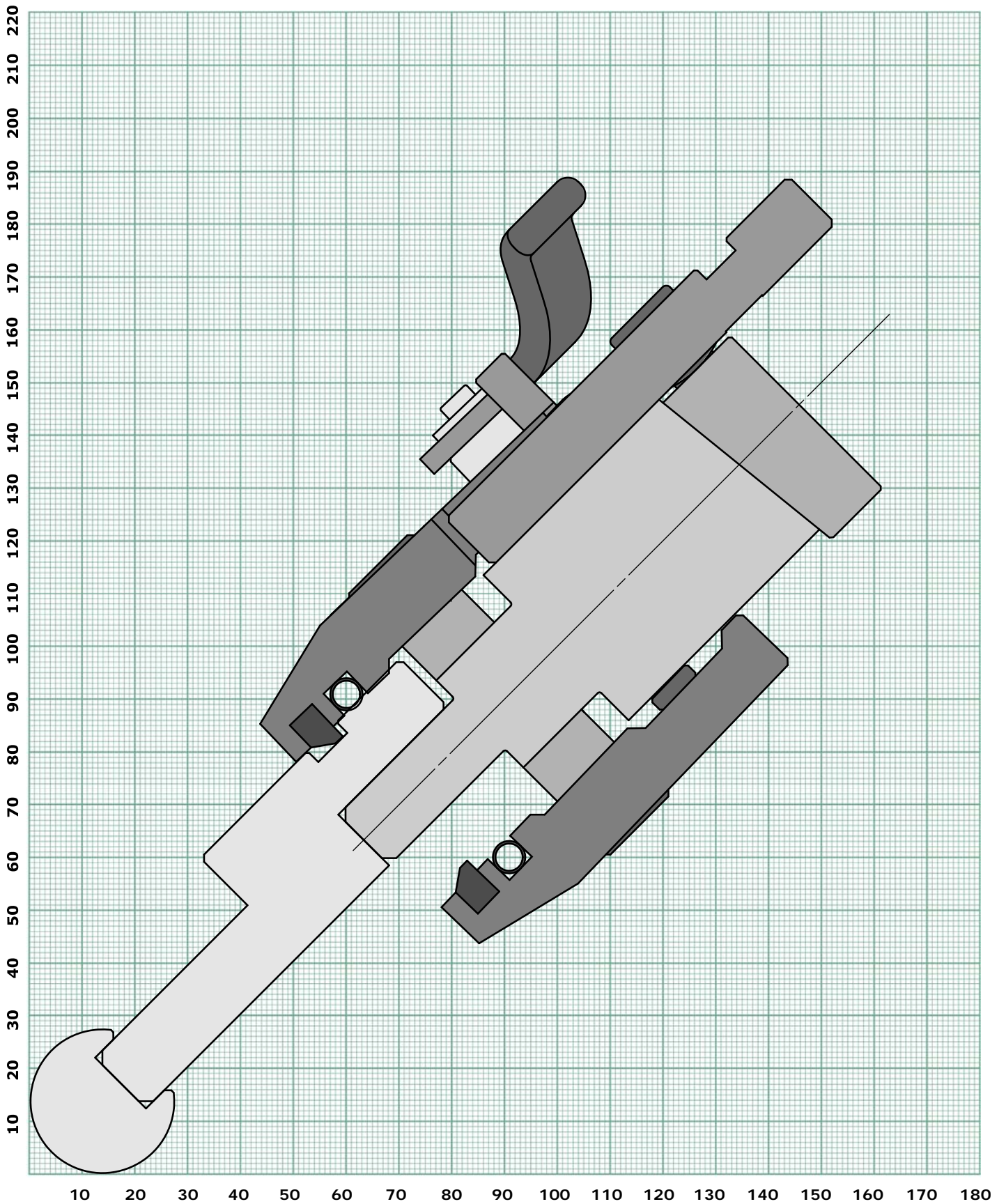

R15 Ruller with EH015 Holder

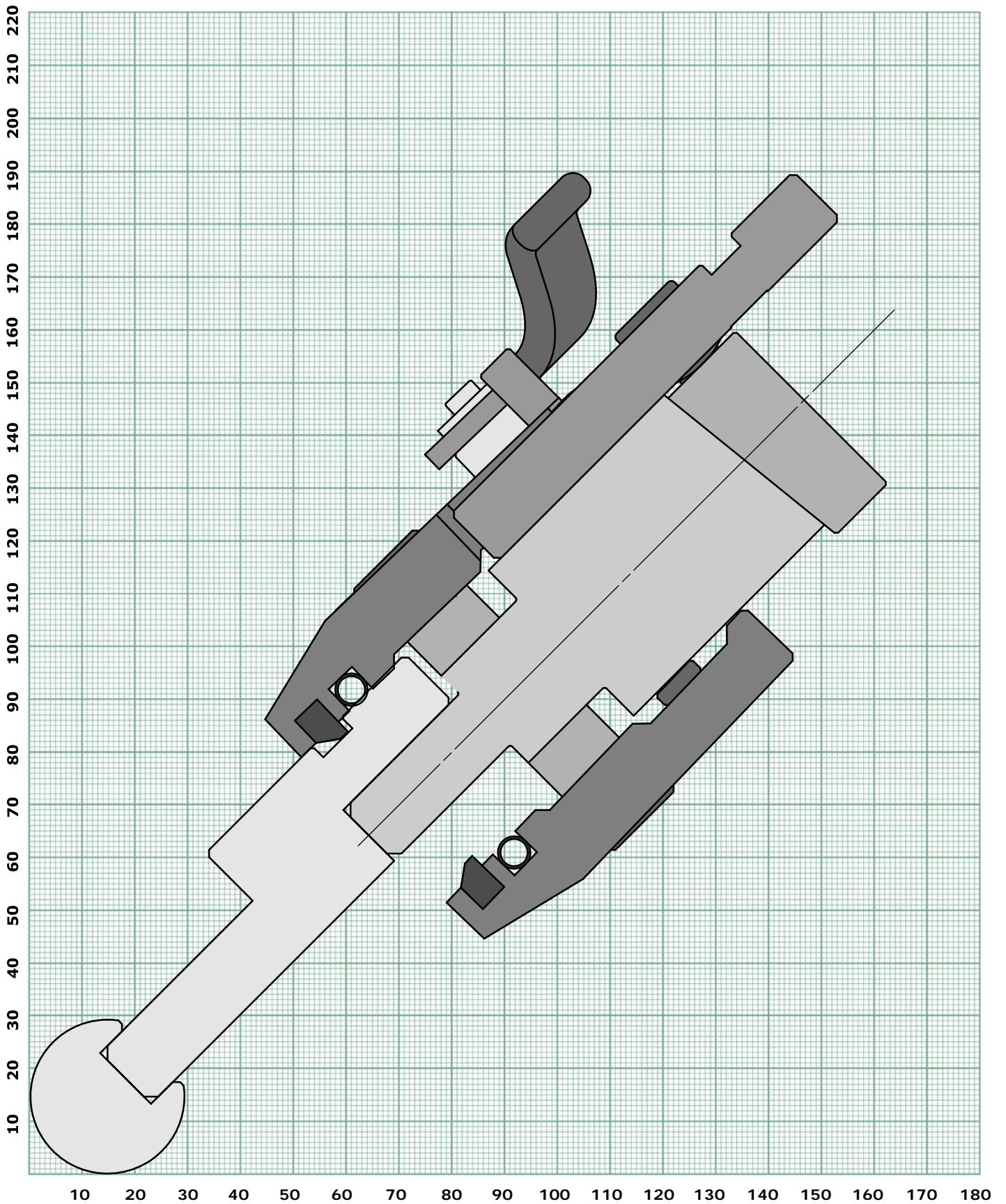

R16 Ruller with EH015 Holder

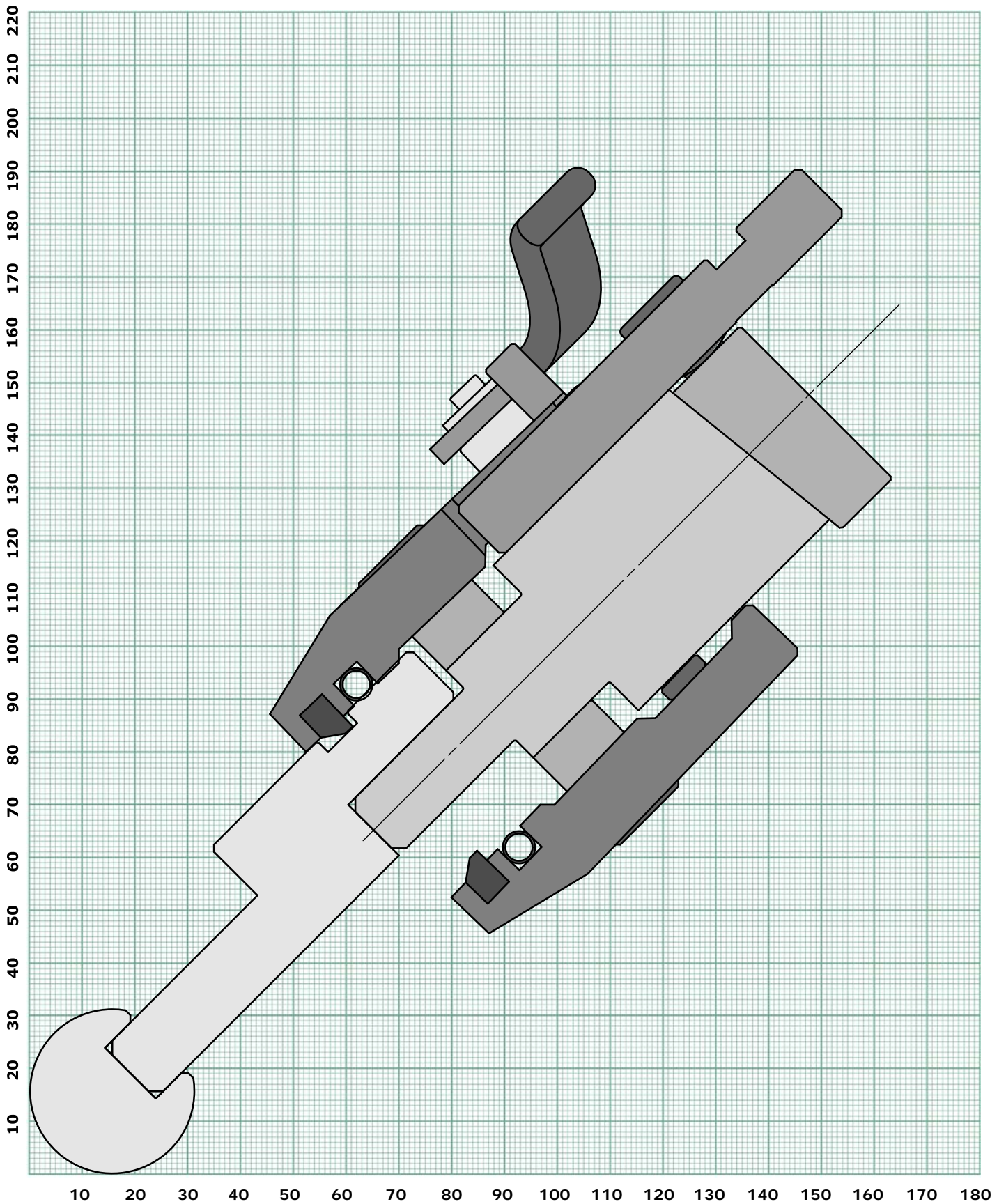

R17,5 Ruller with EH015 Holder

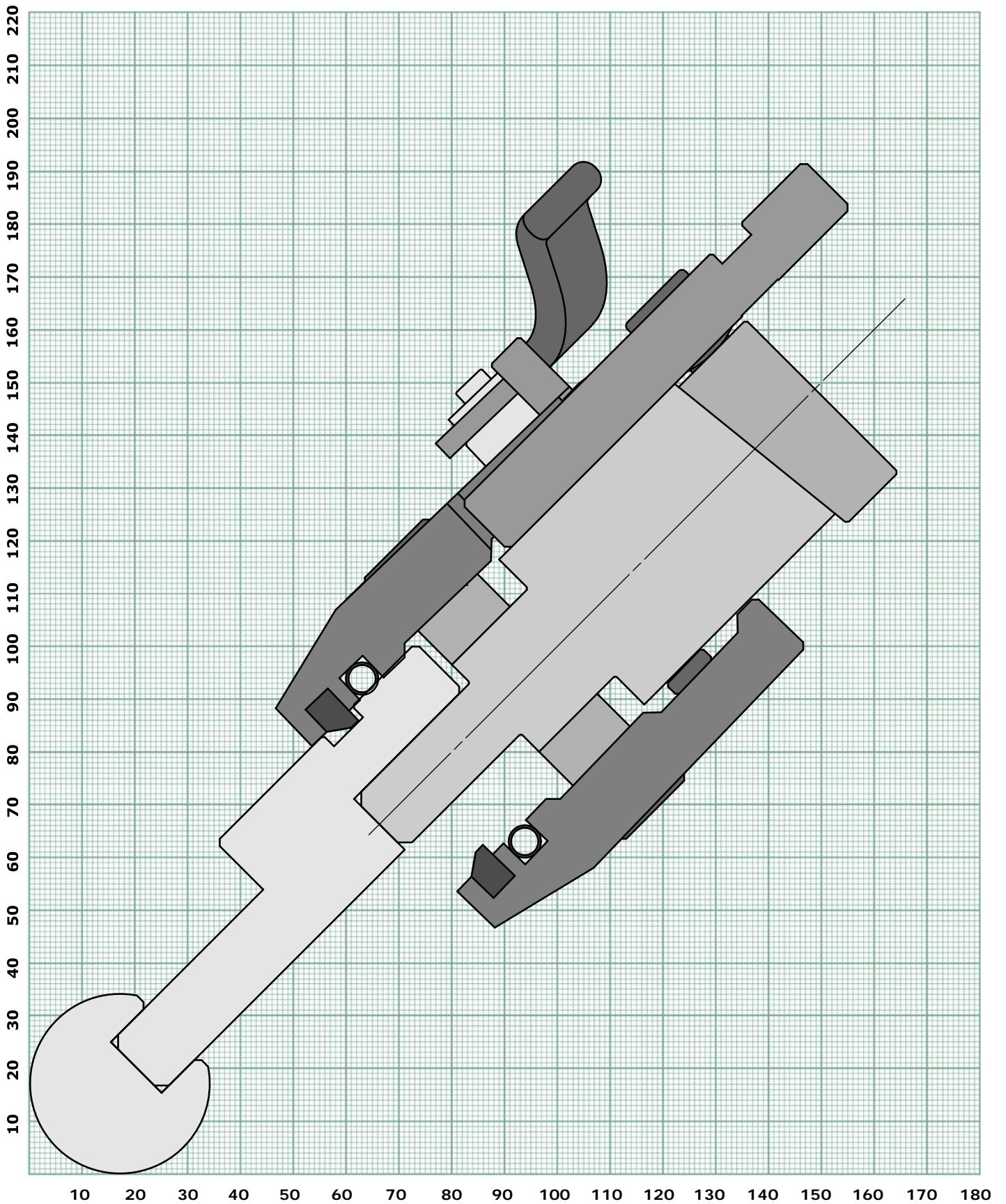

R20 Ruller with EH015 Holder

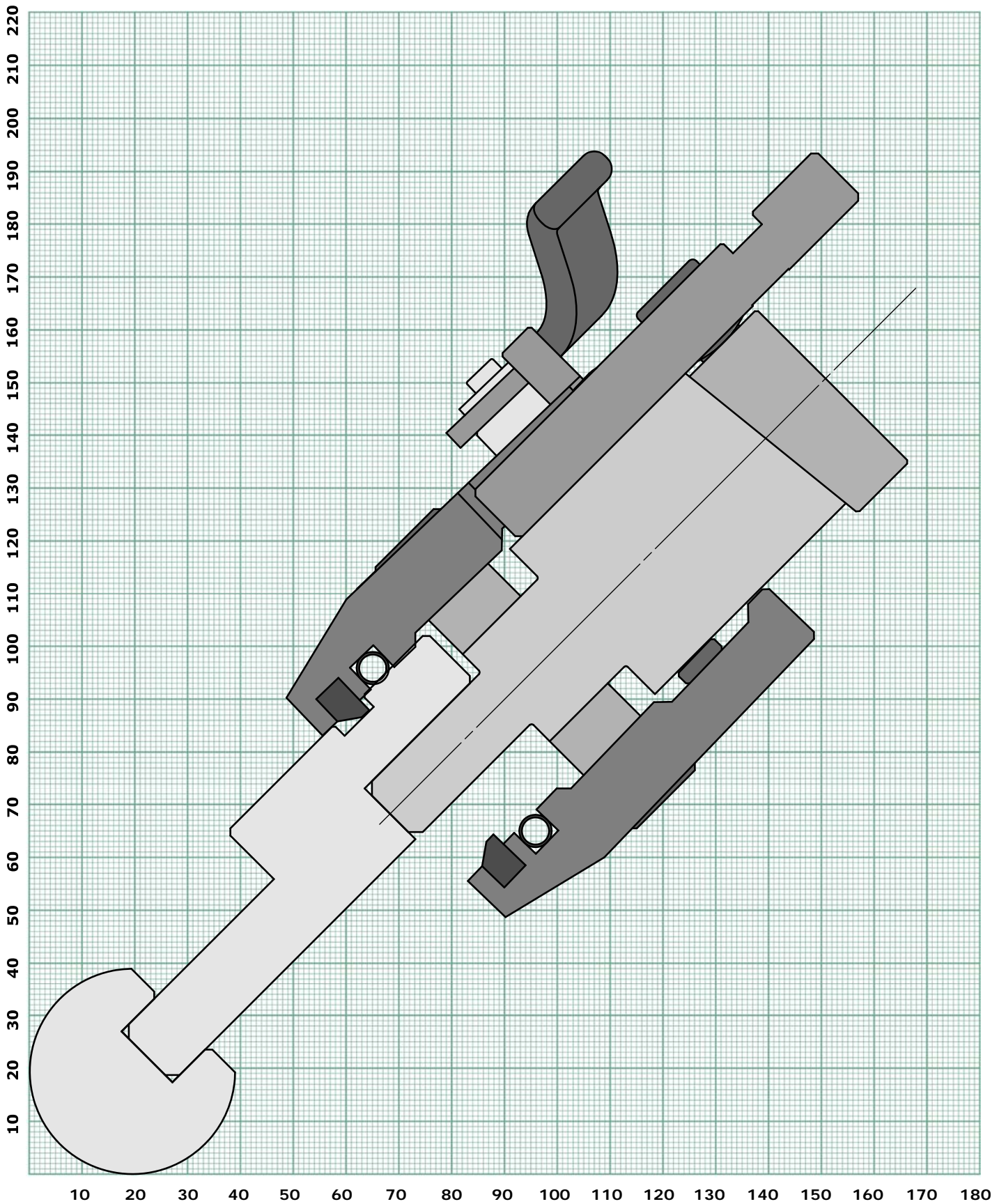

R22,5 Ruller with EH015 Holder

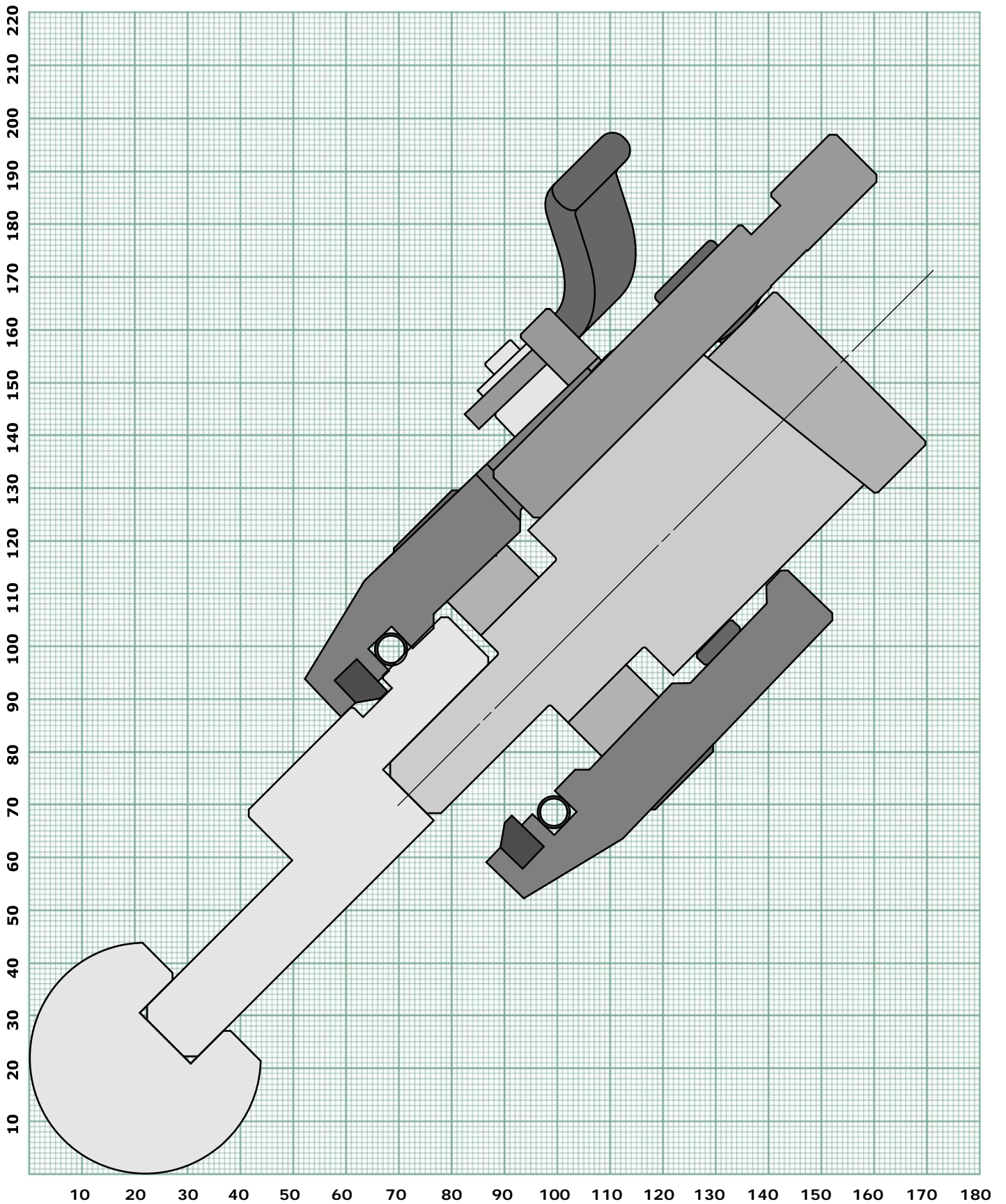

R25 Ruller with EH015 Holder

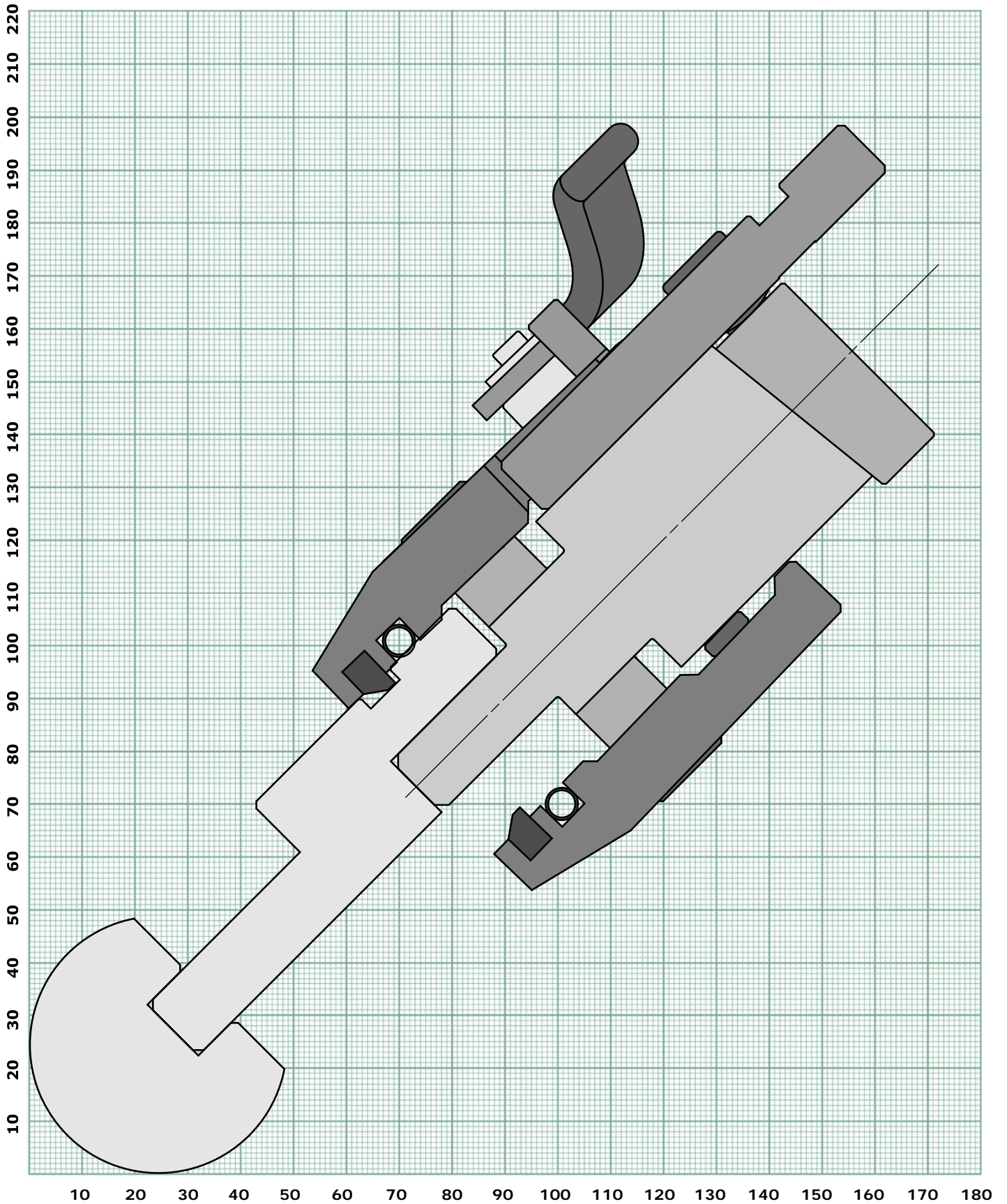

R30 Ruller with EH015 Holder

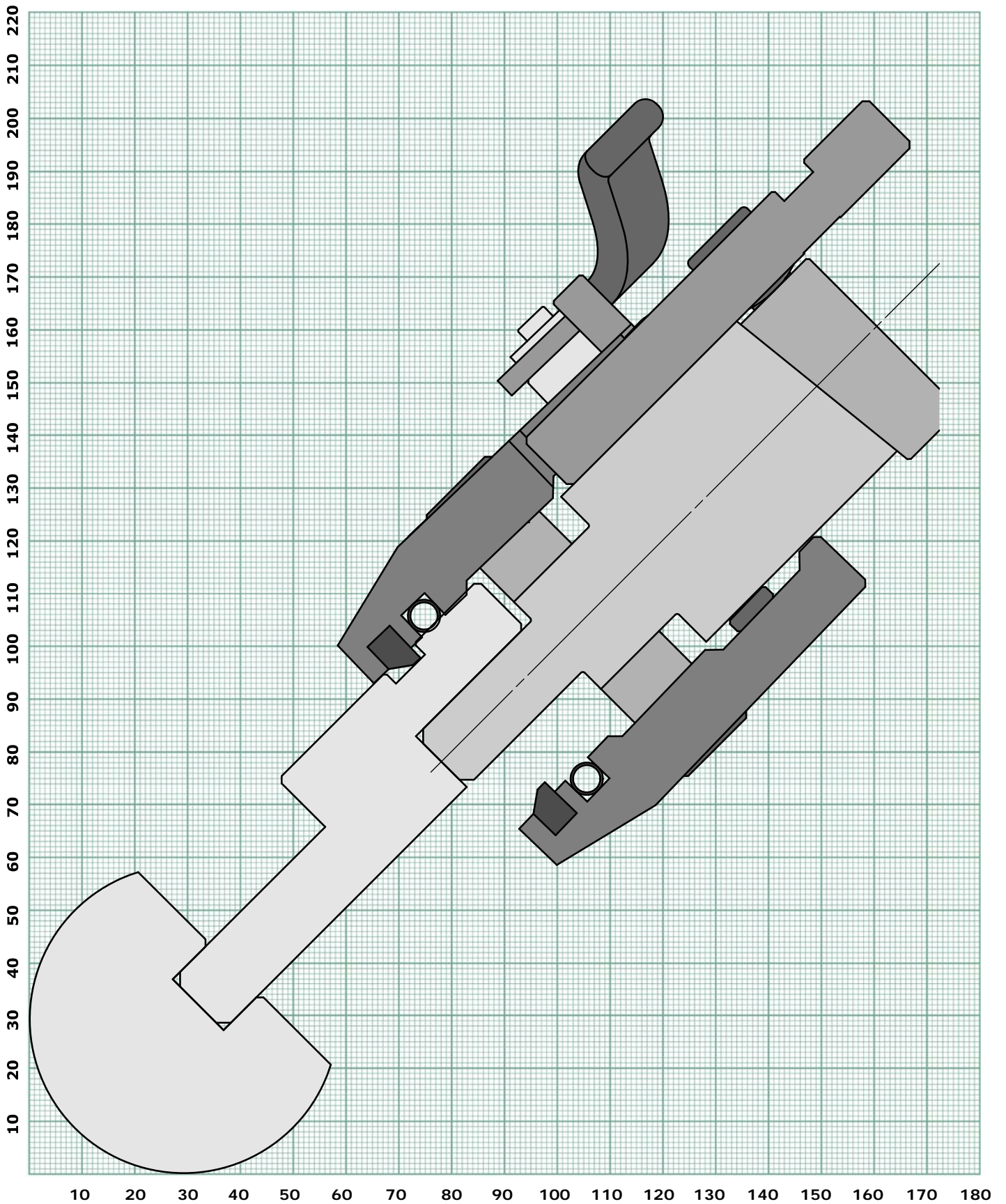

R35 Ruller with EH015 Holder

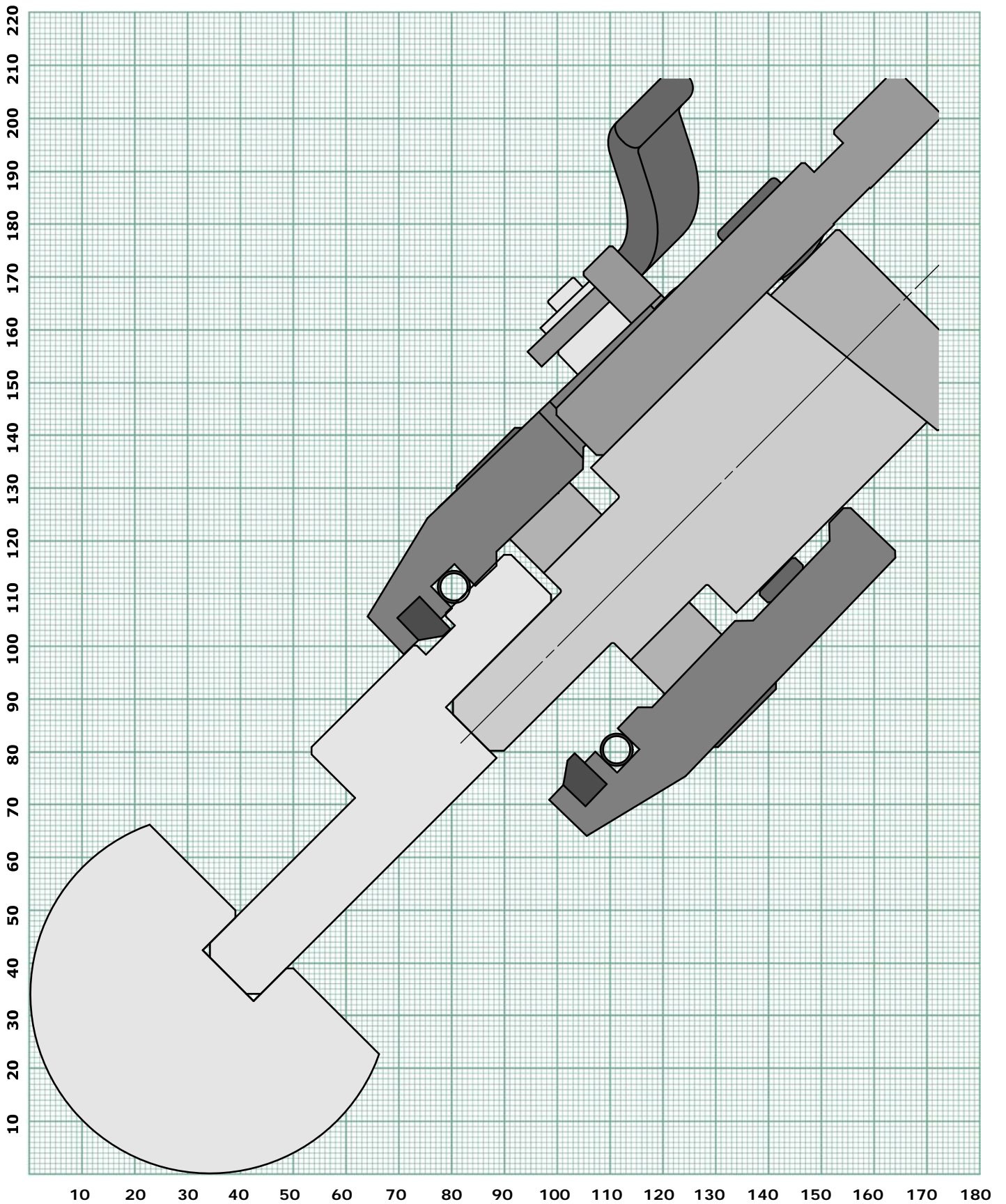

R40 Ruller with EH015 Holder

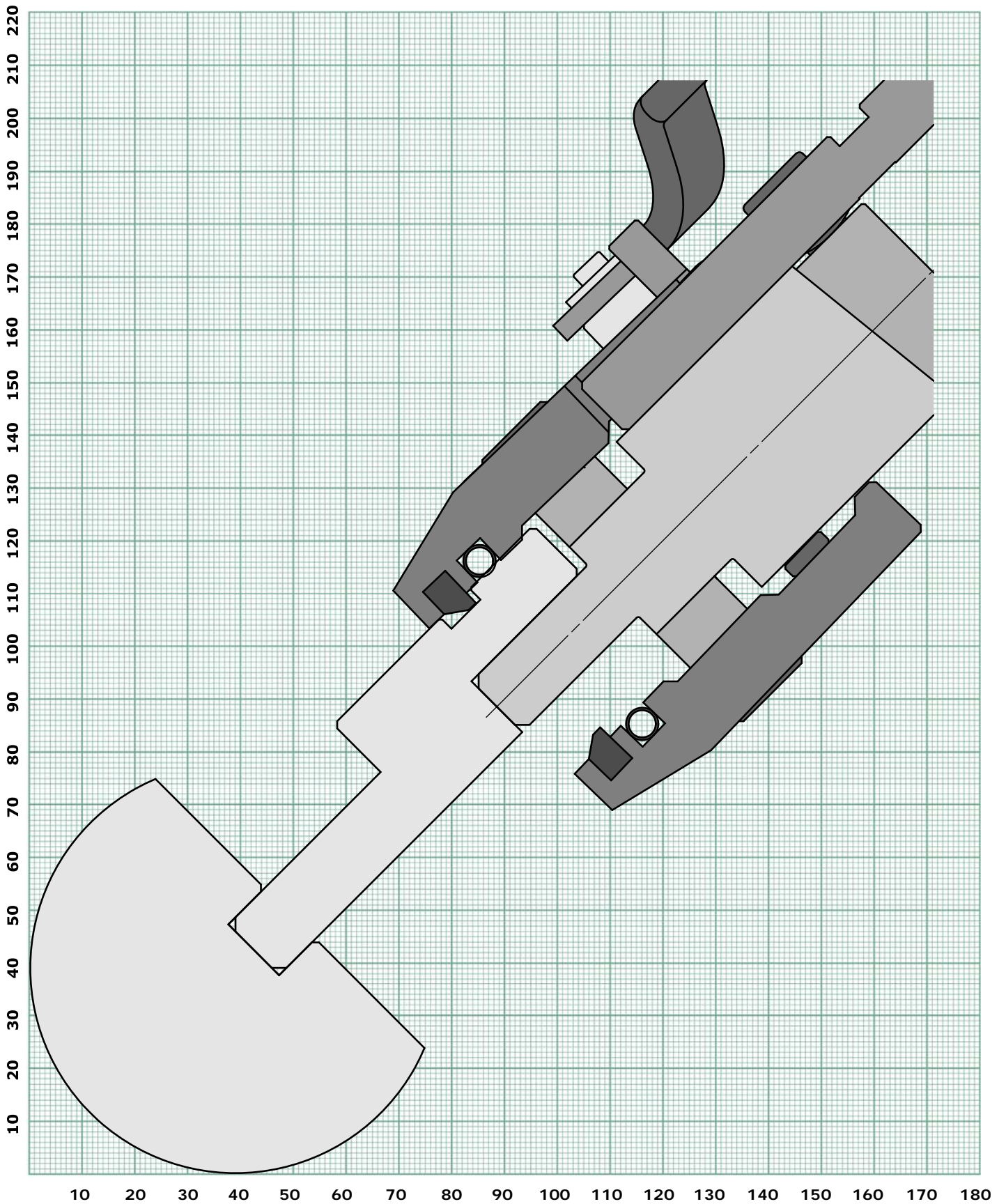

R45 Ruller with EH015 Holder

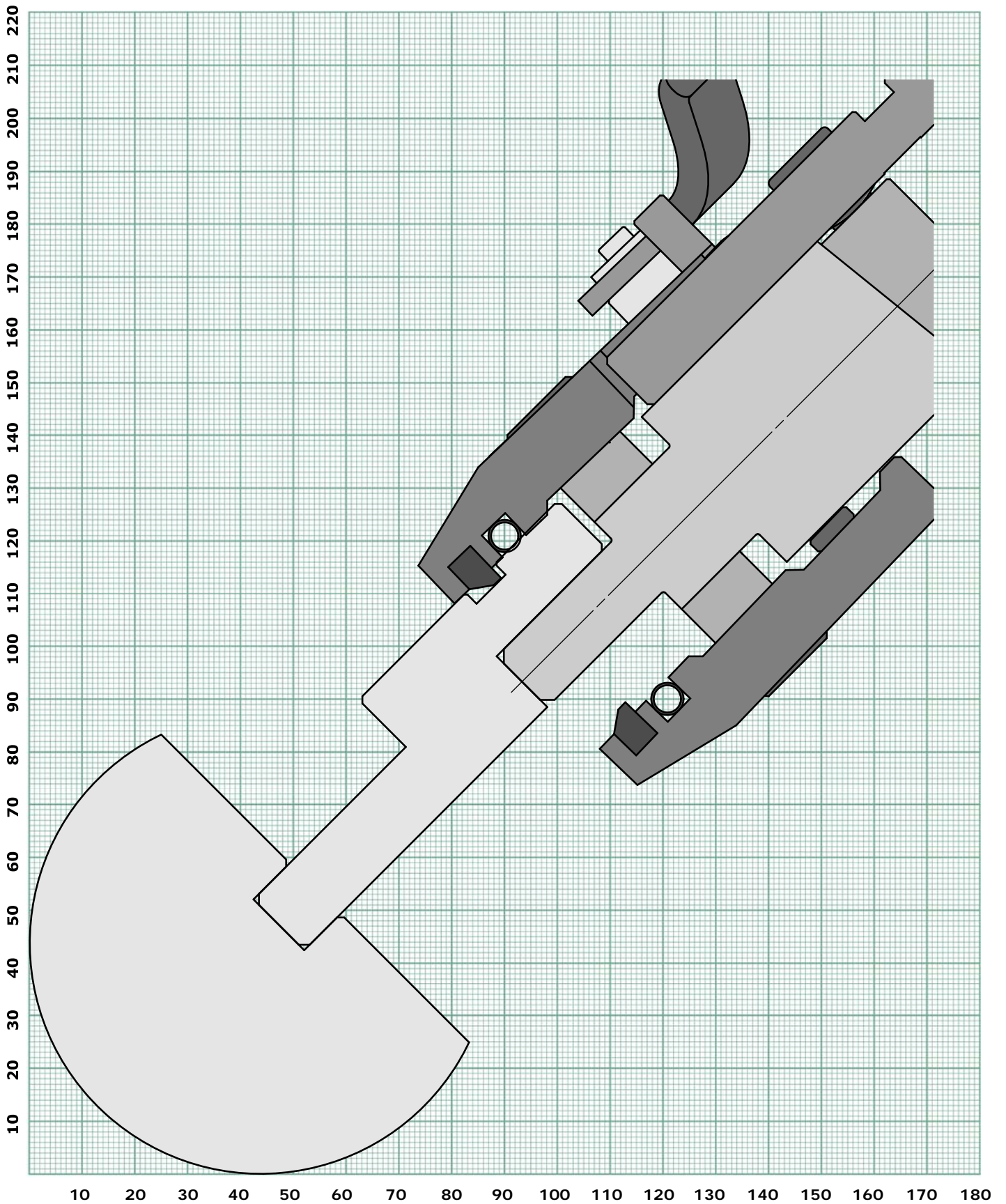

R50 Ruller with EH015 Holder

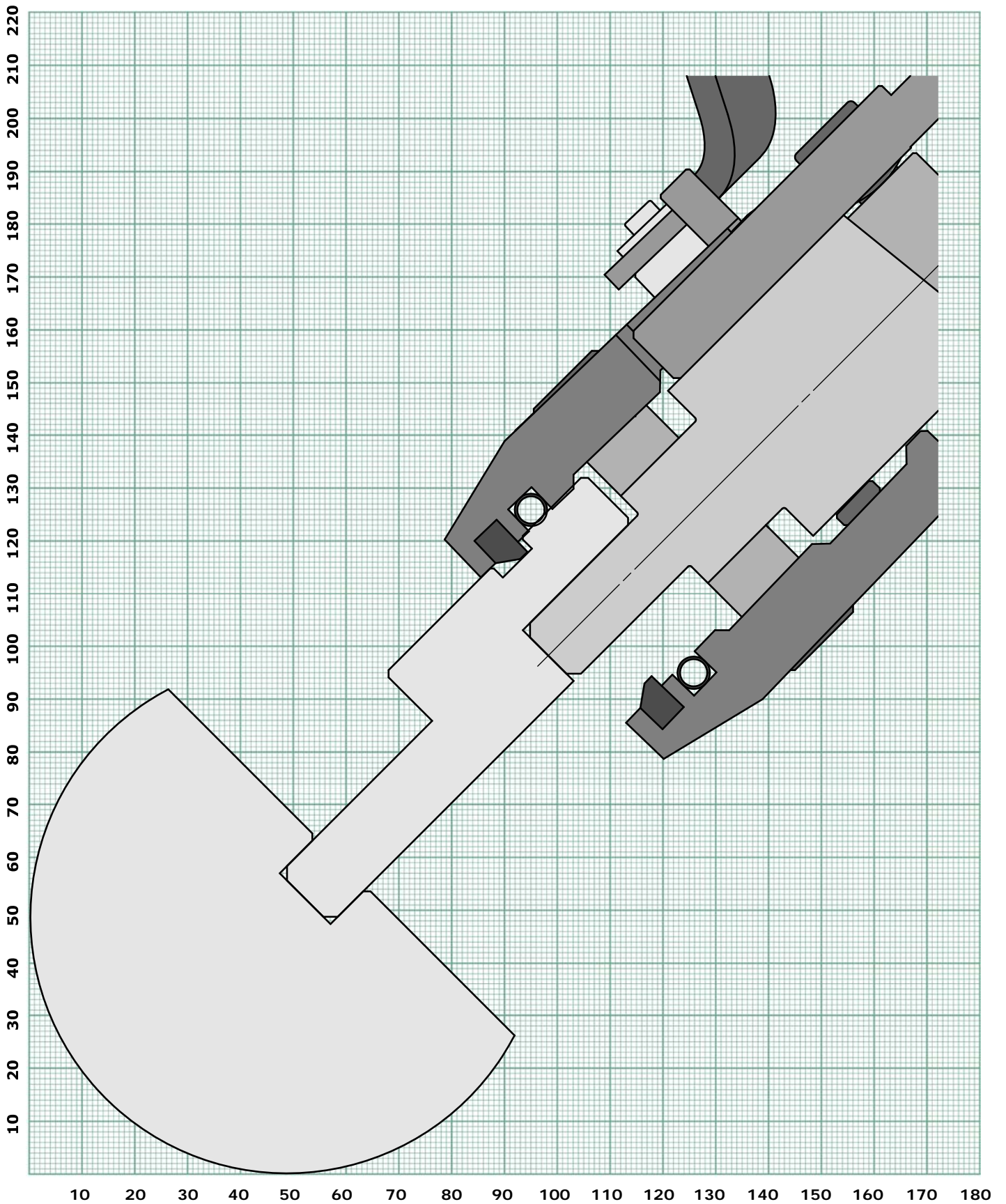

R7 Ruller with EH016 Holder

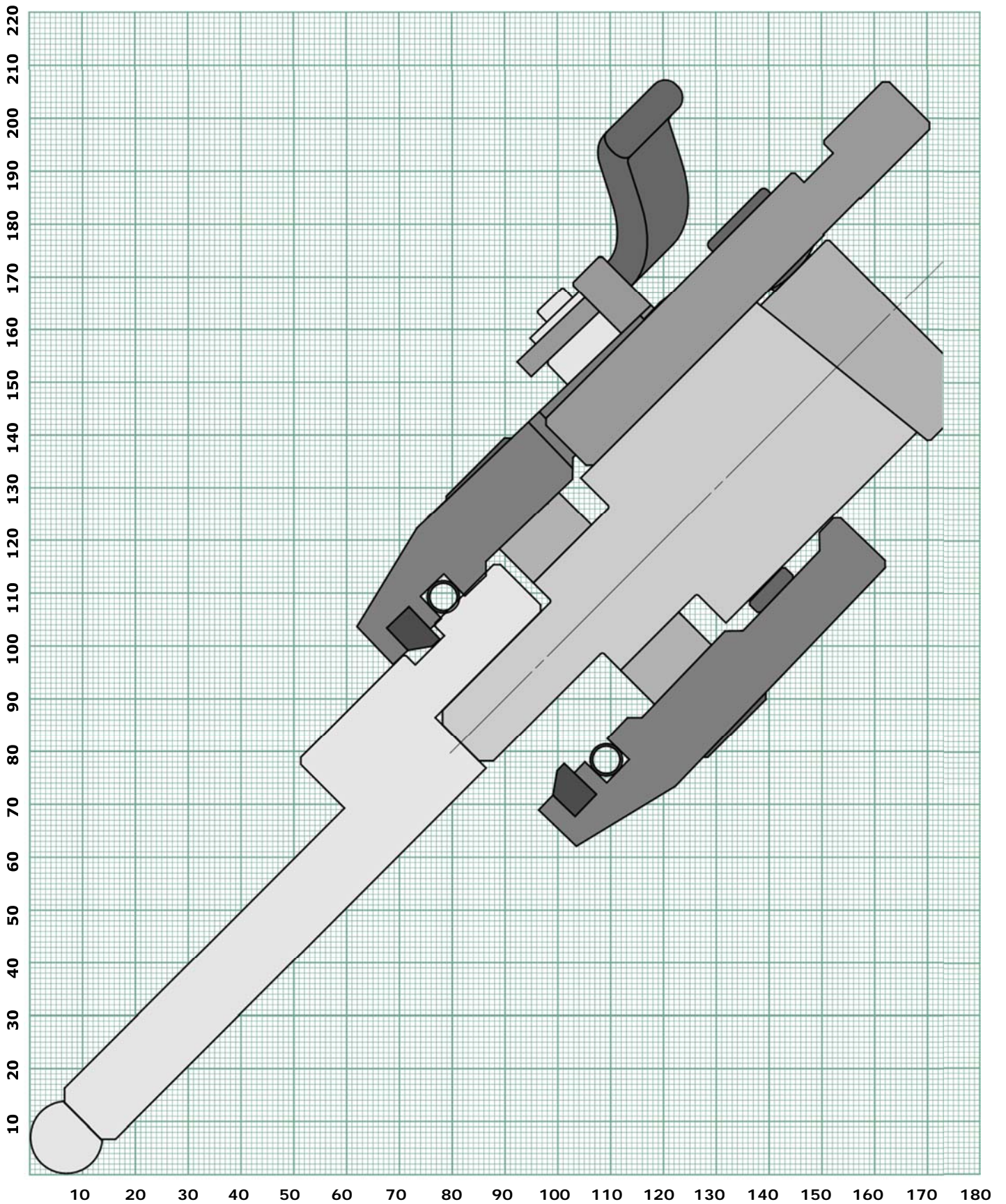

R8 Ruller with EH016 Holder

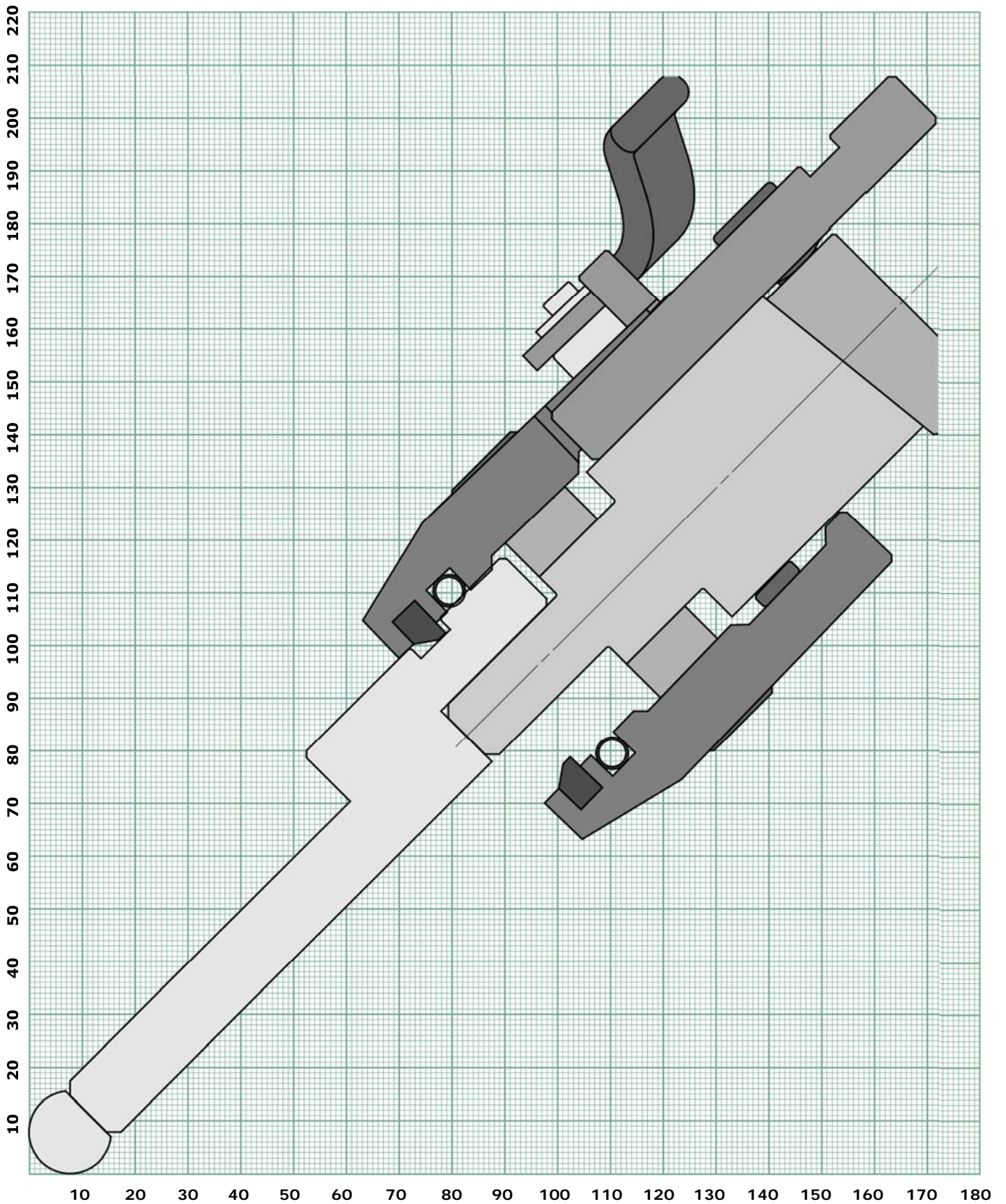

R9 Ruller with EH016 Holder

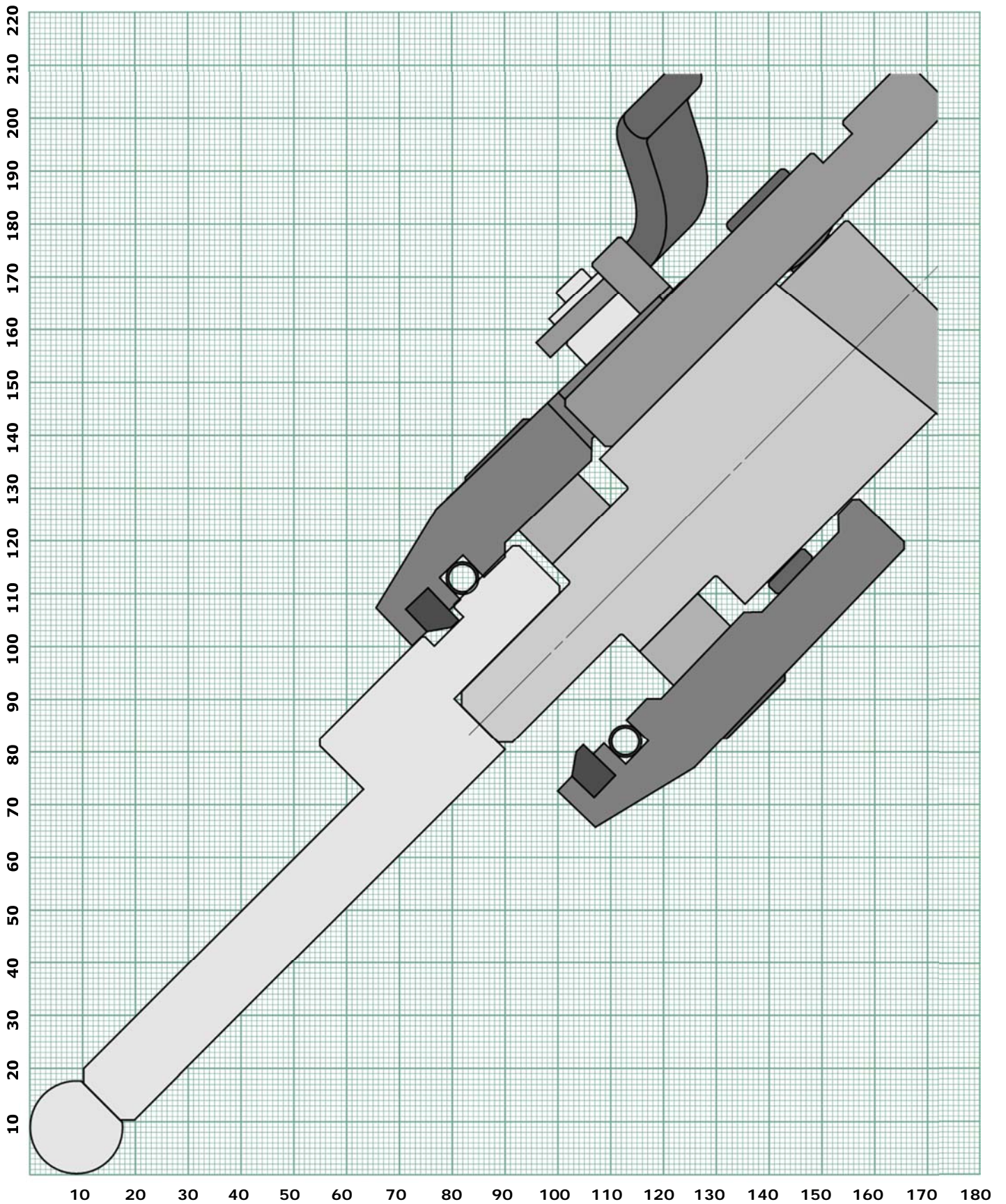

R10 Ruller with EH016 Holder

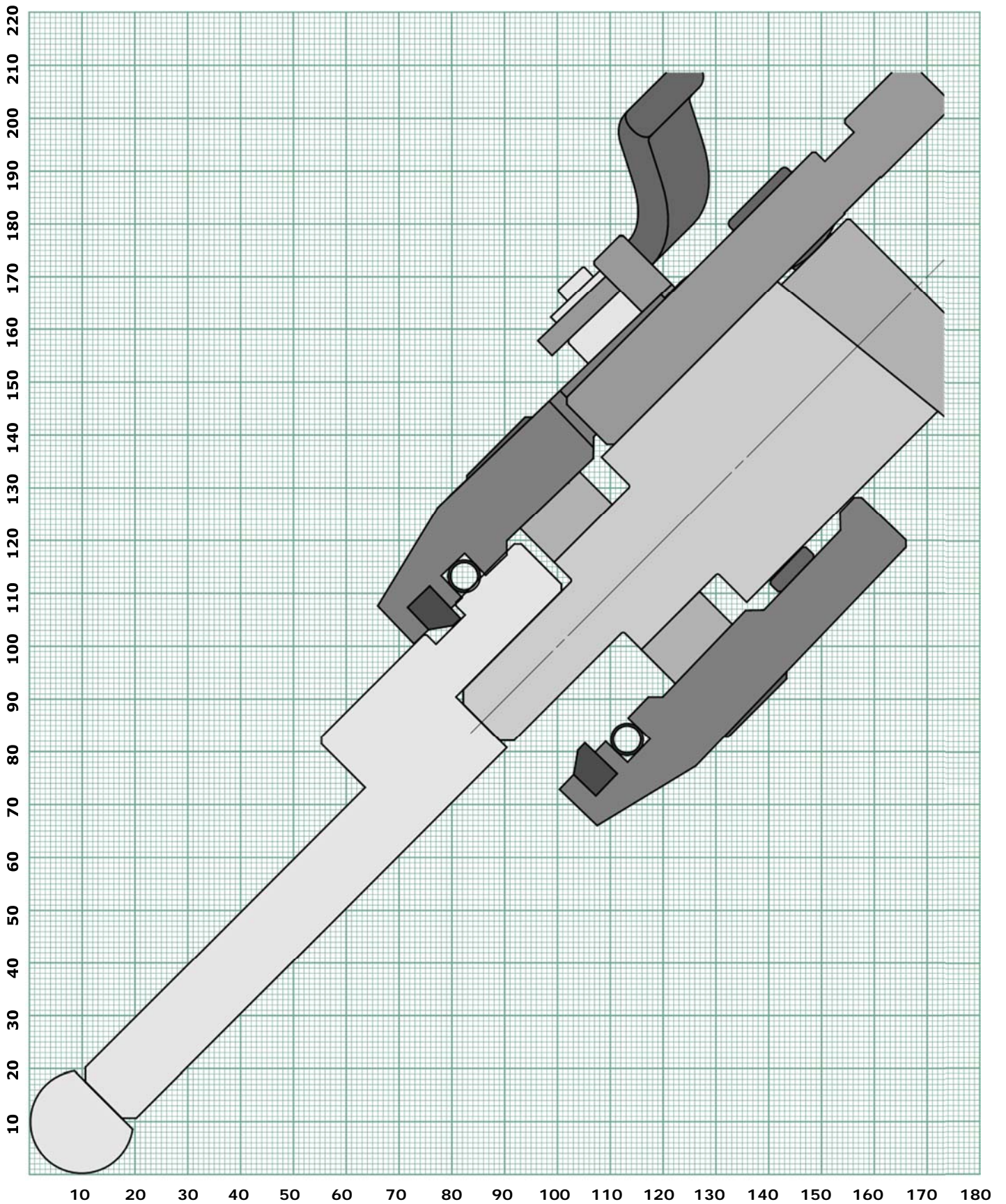

R11 Ruller with EH016 Holder

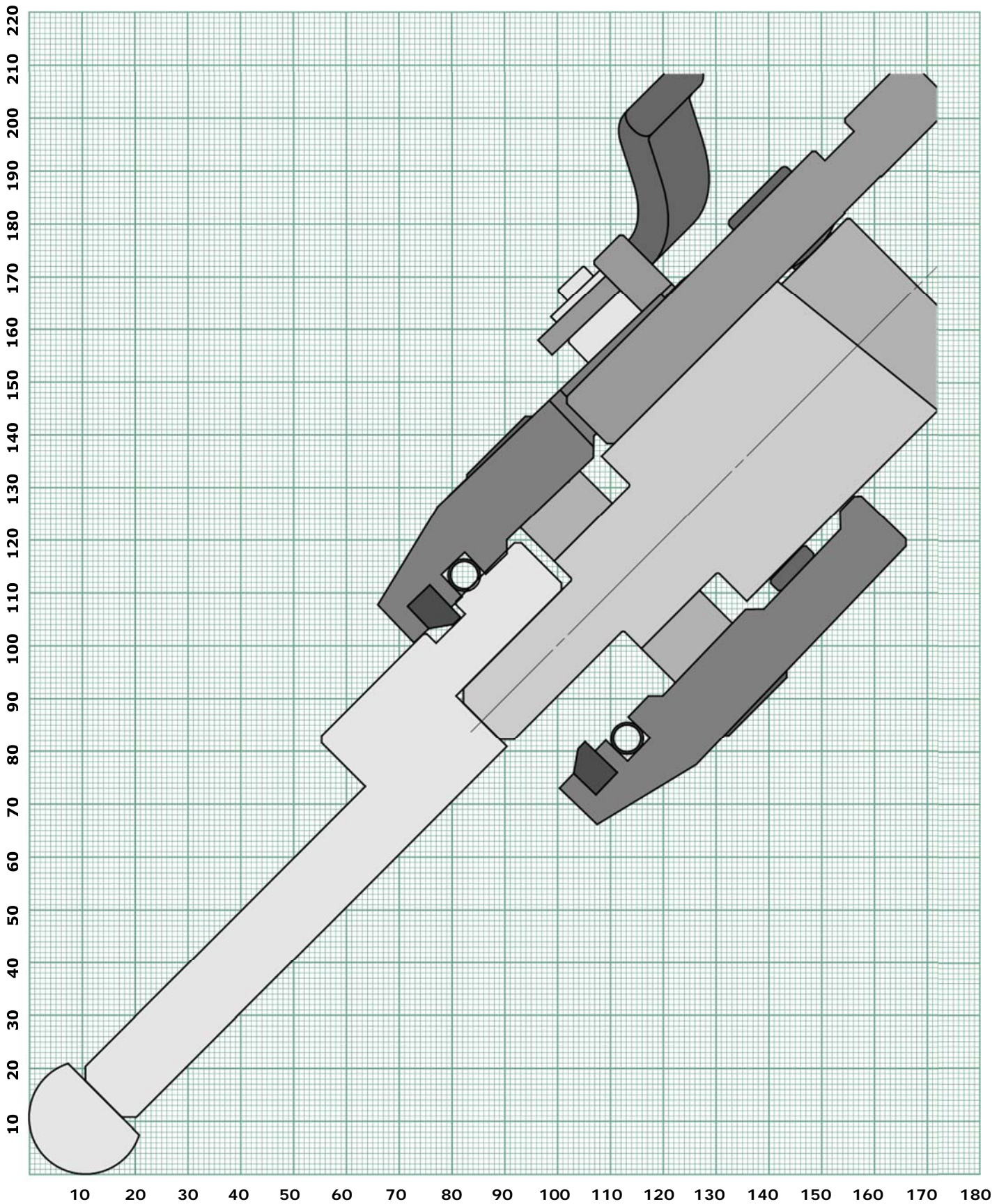

R12,5 Ruller with EH016 Holder

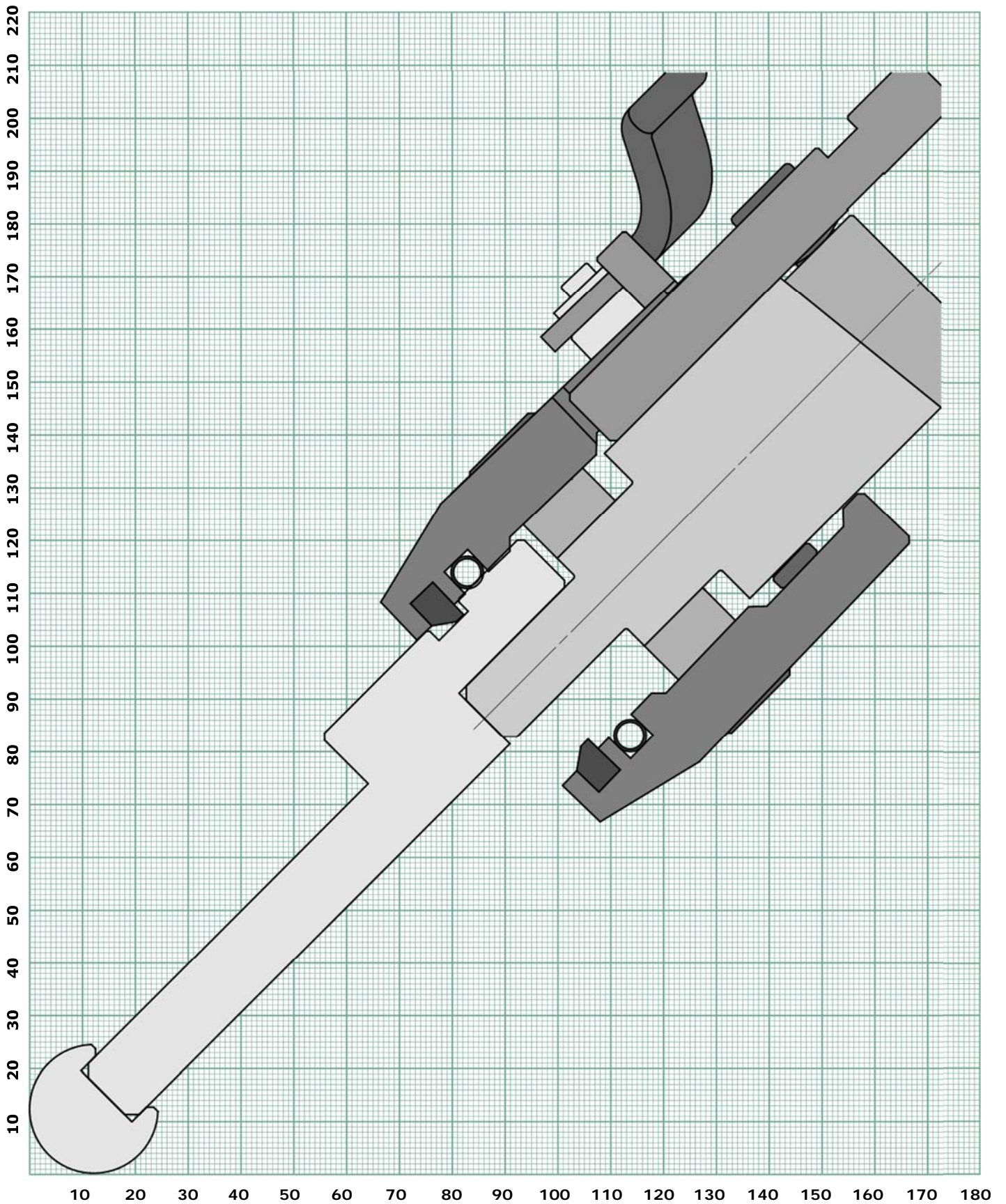

R14 Ruller with EH016 Holder

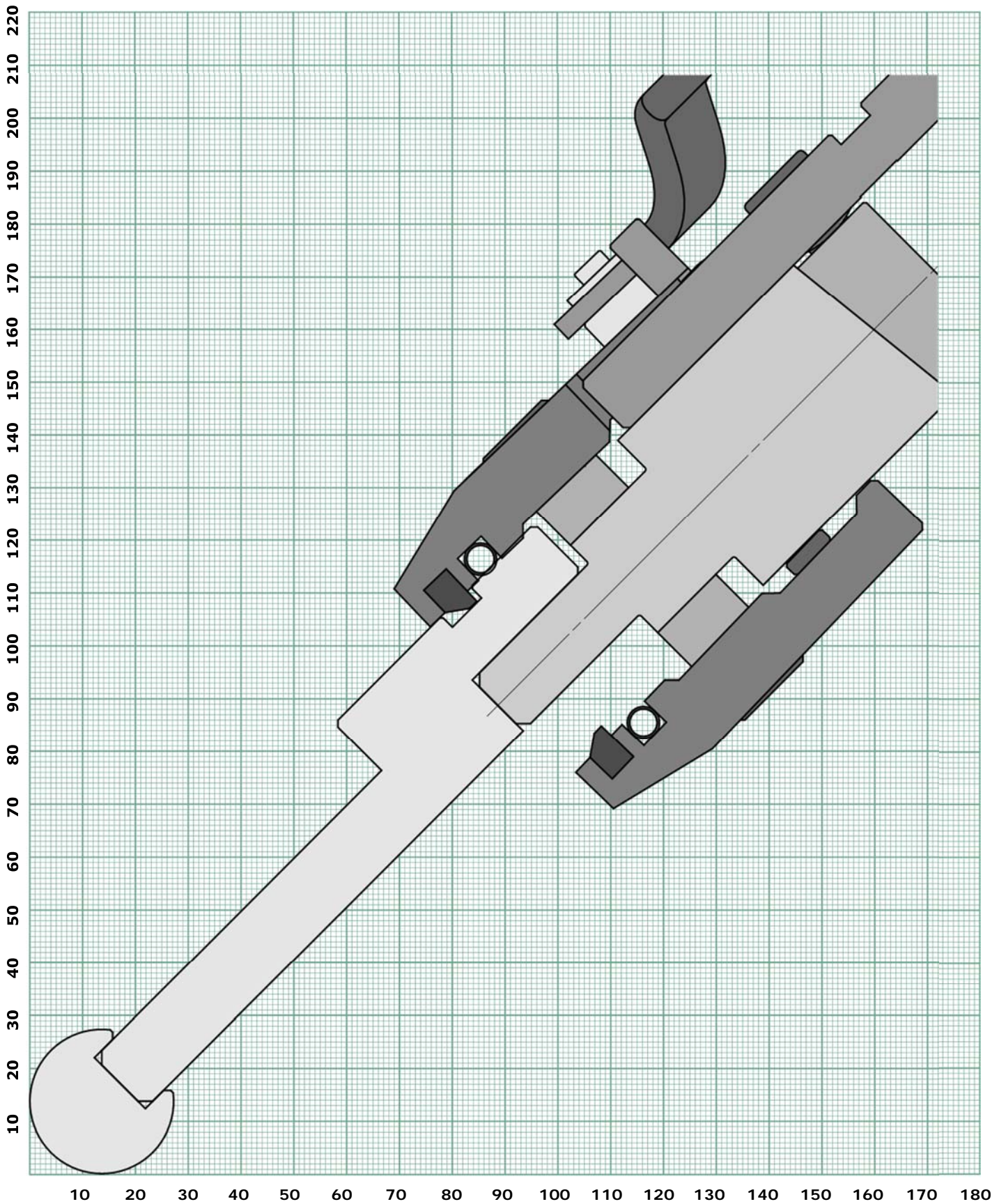

R15 Ruller with EH016 Holder

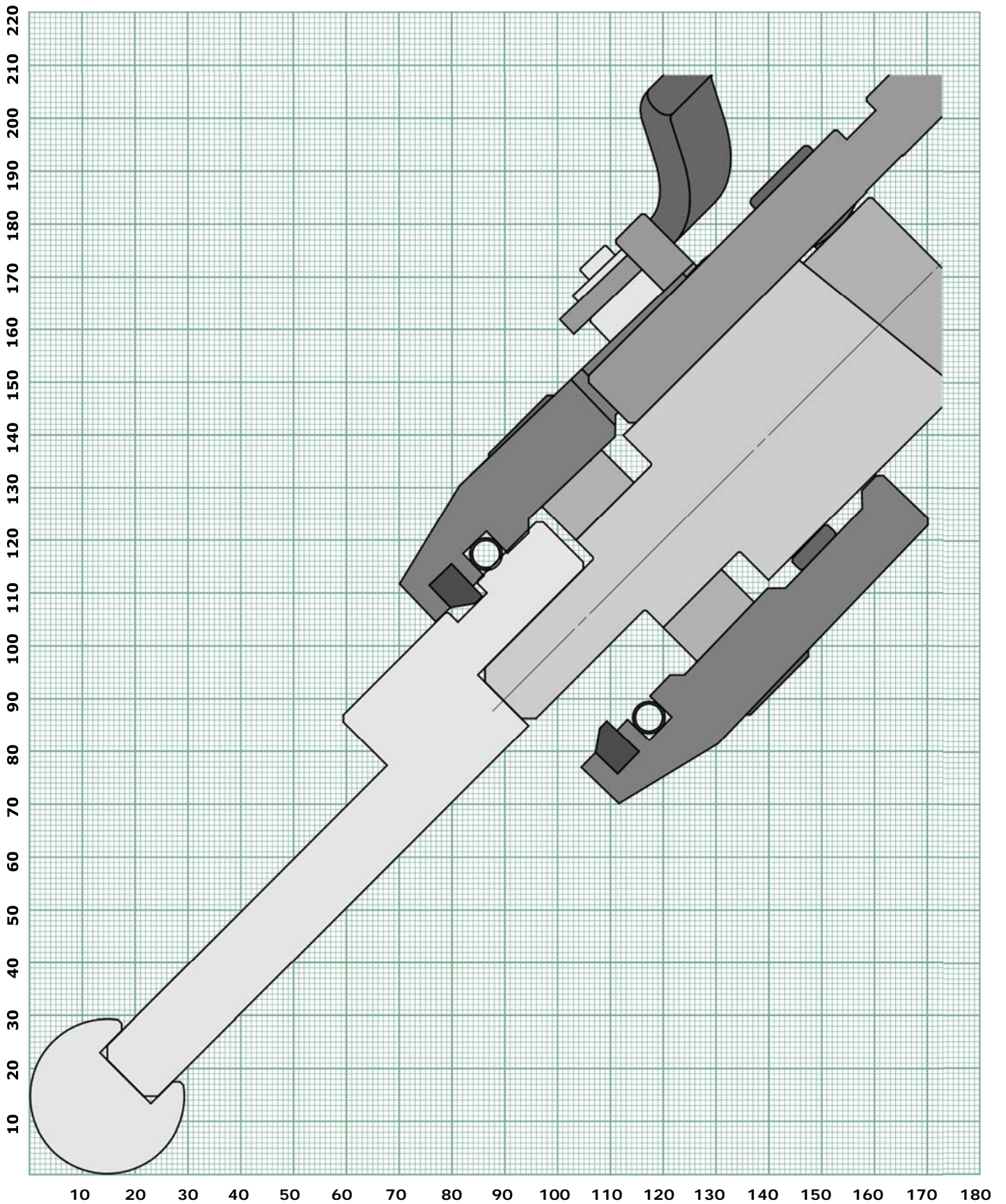

R16 Ruller with EH016 Holder

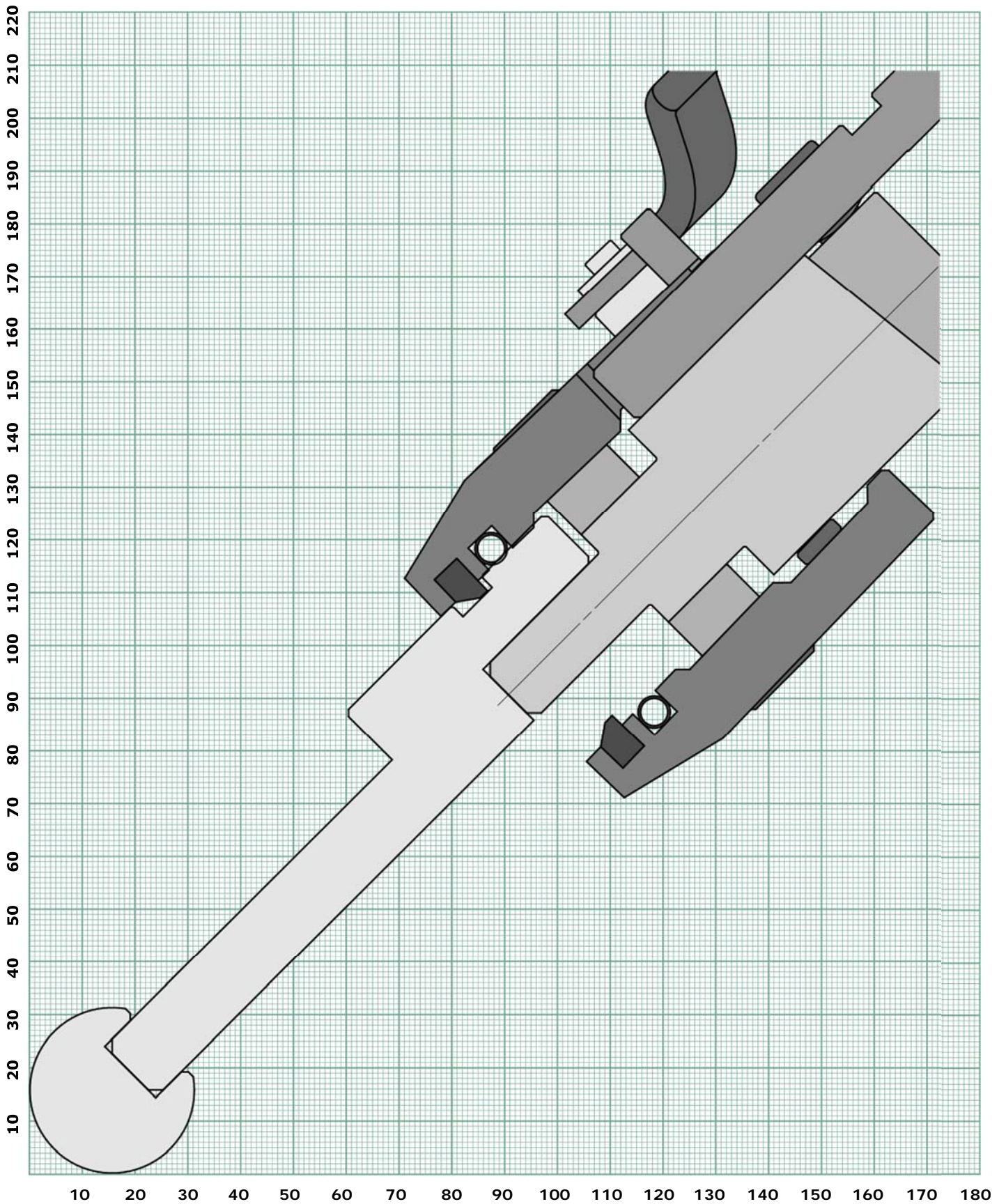

R17,5 Ruller with EH016 Holder

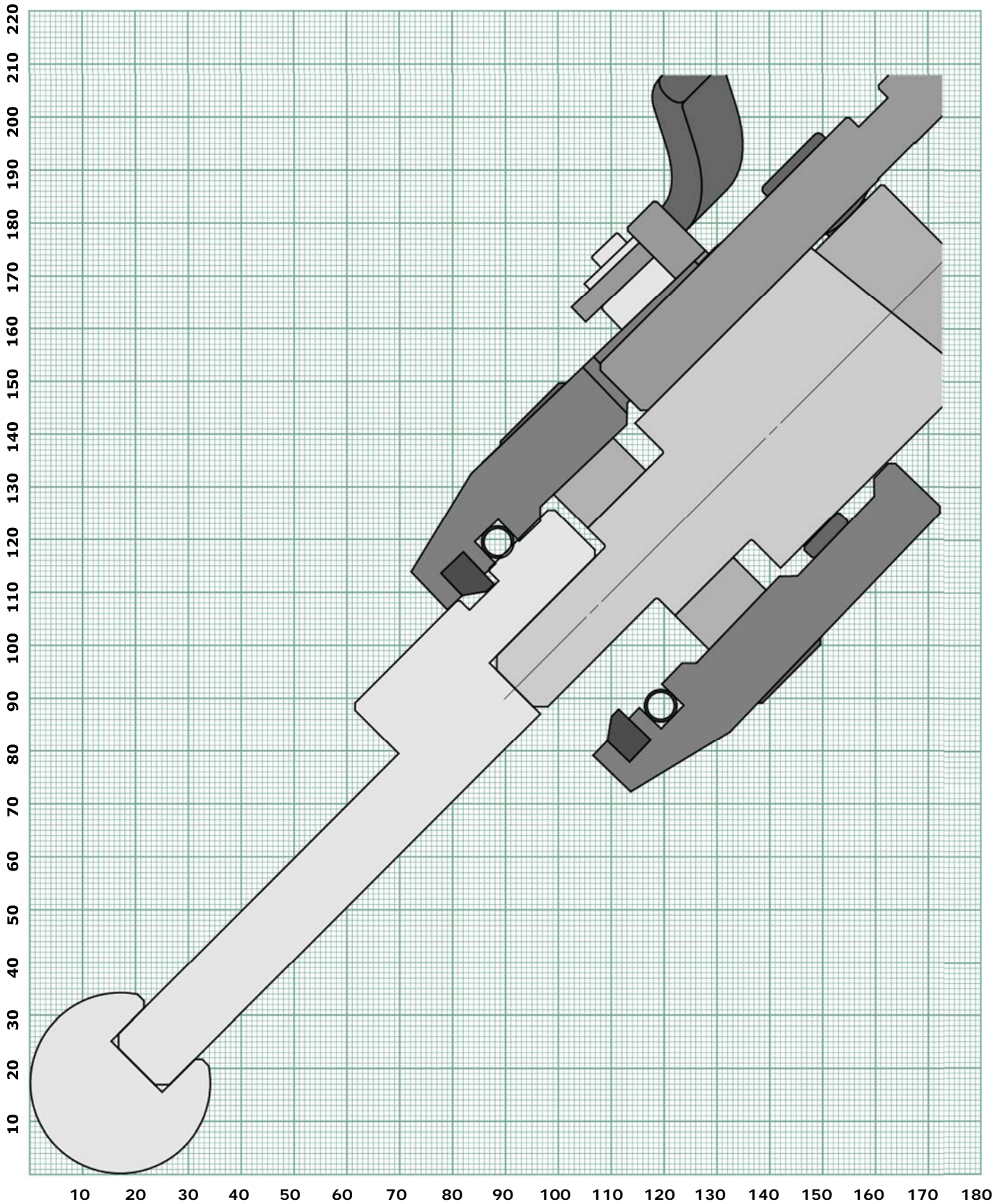

R20 Ruller with EH016 Holder

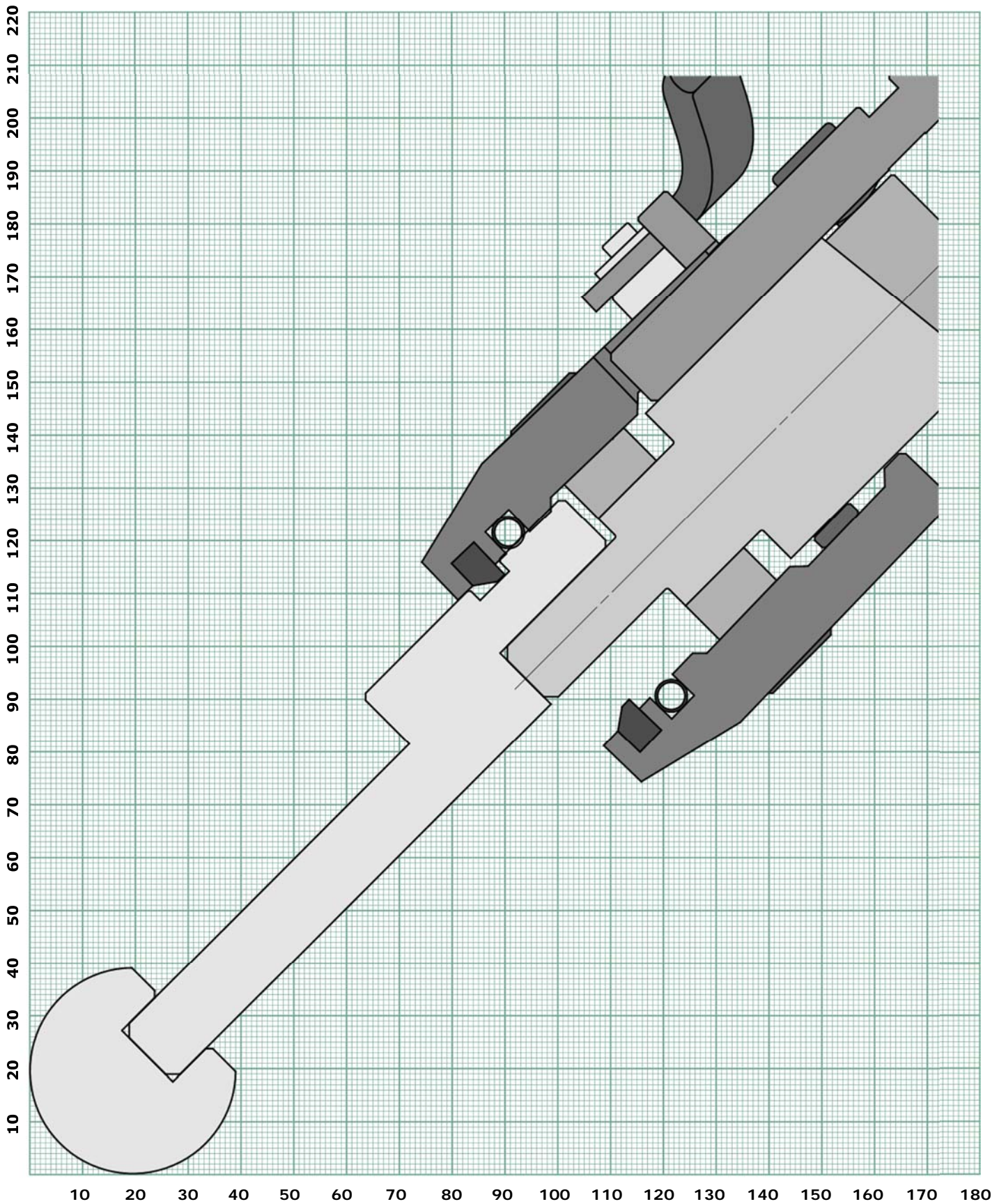

R22,5 Ruller with EH016 Holder

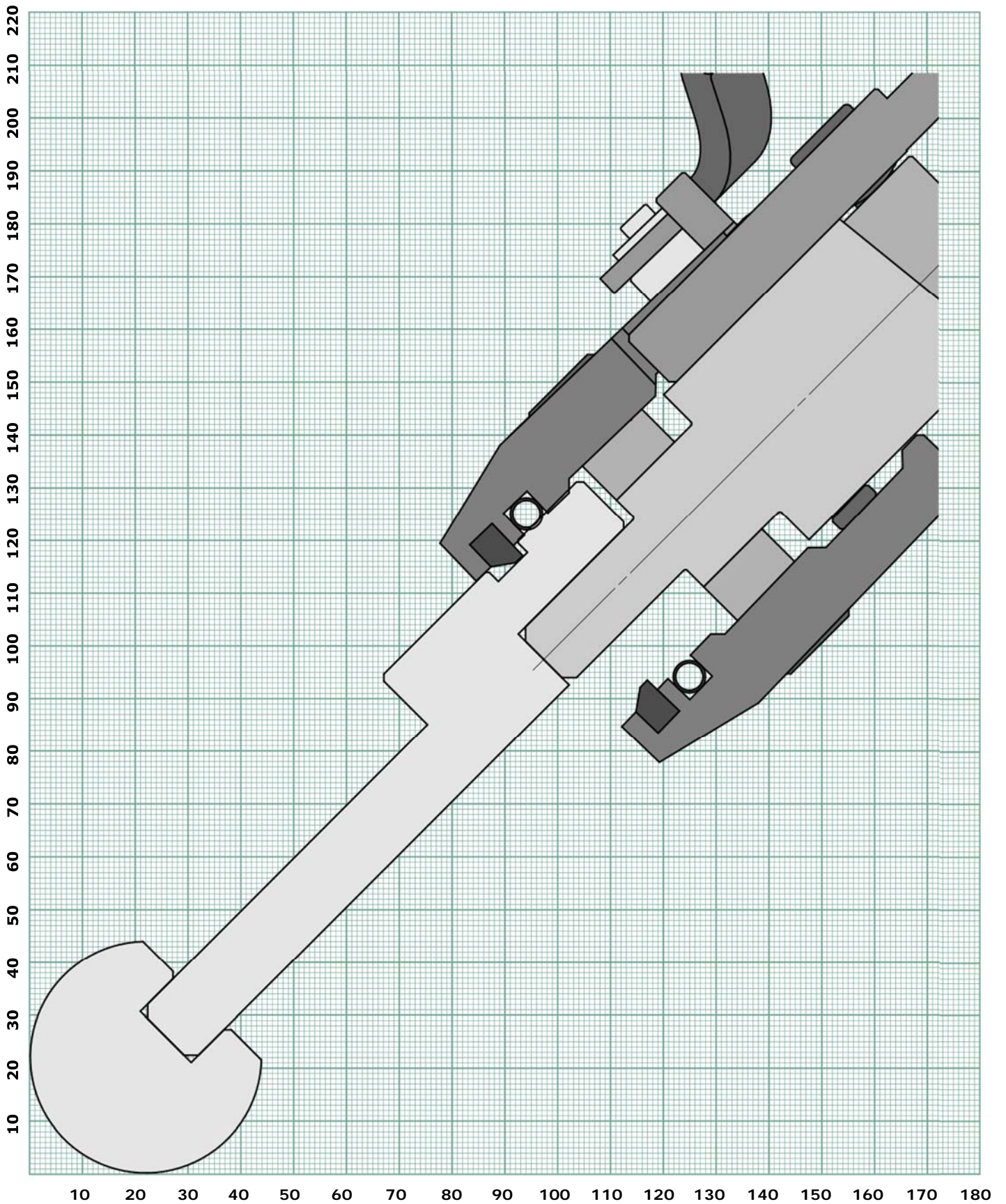

R25 Ruller with EH016 Holder

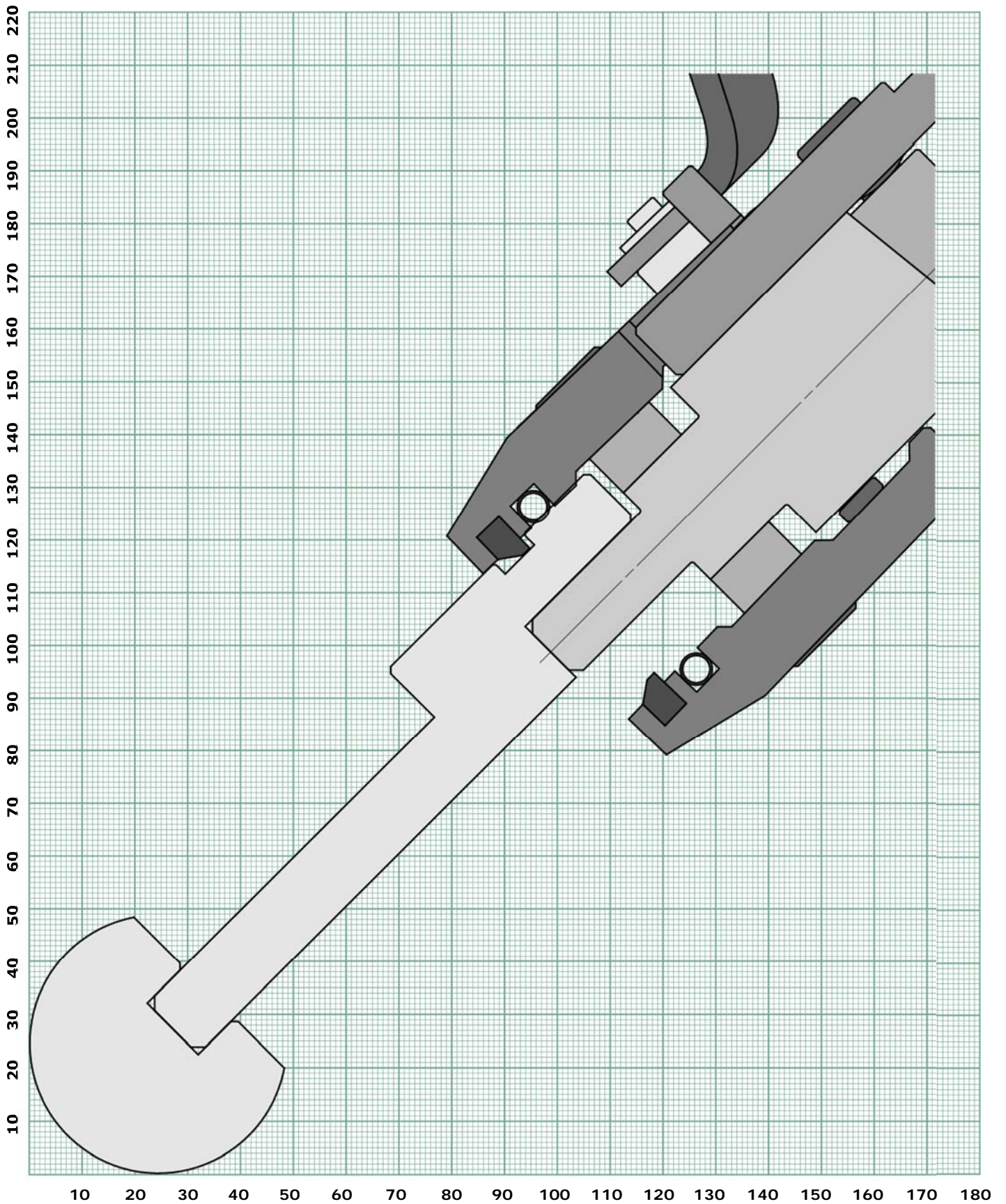

R30 Ruller with EH016 Holder

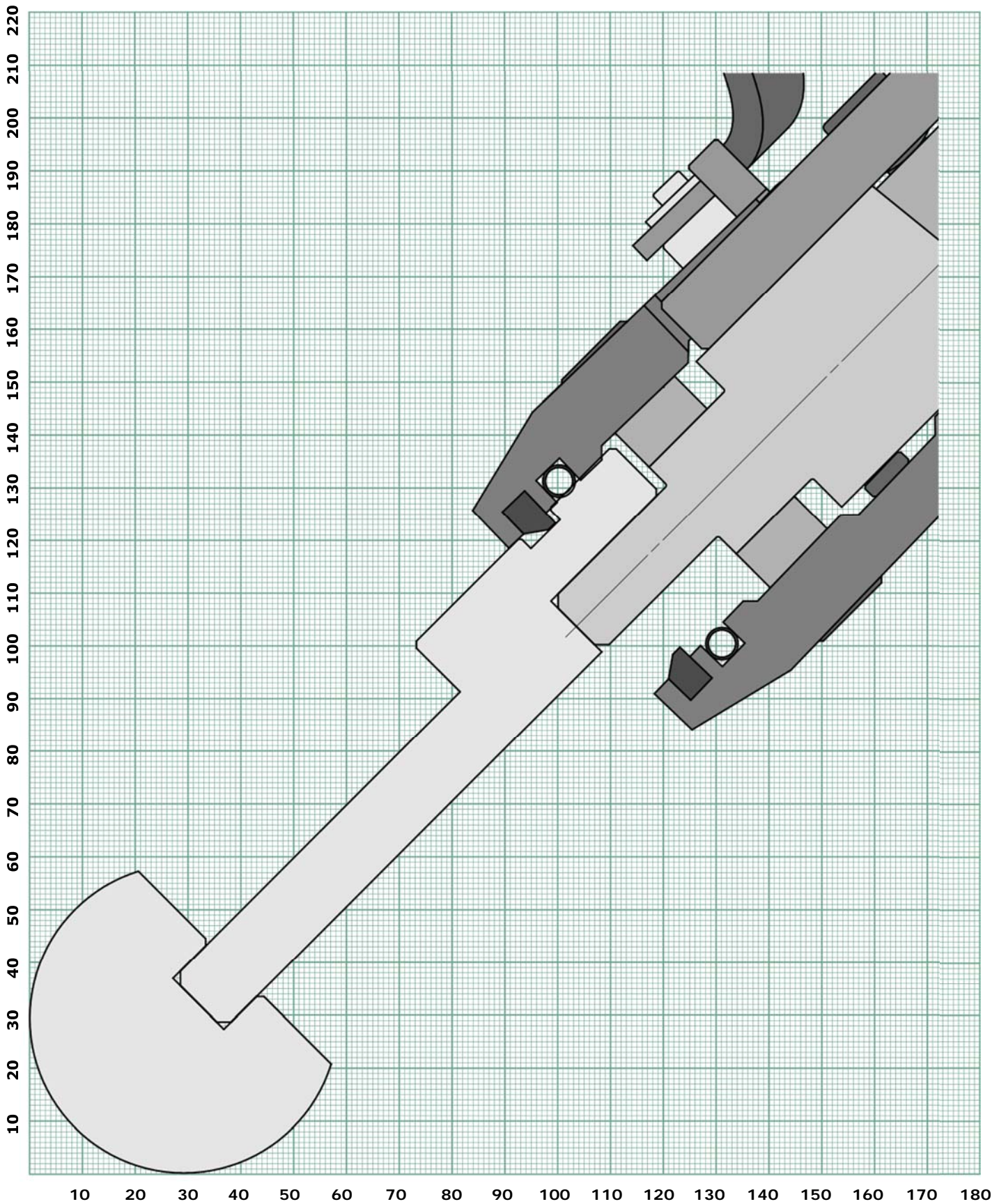

R35 Ruller with EH016 Holder

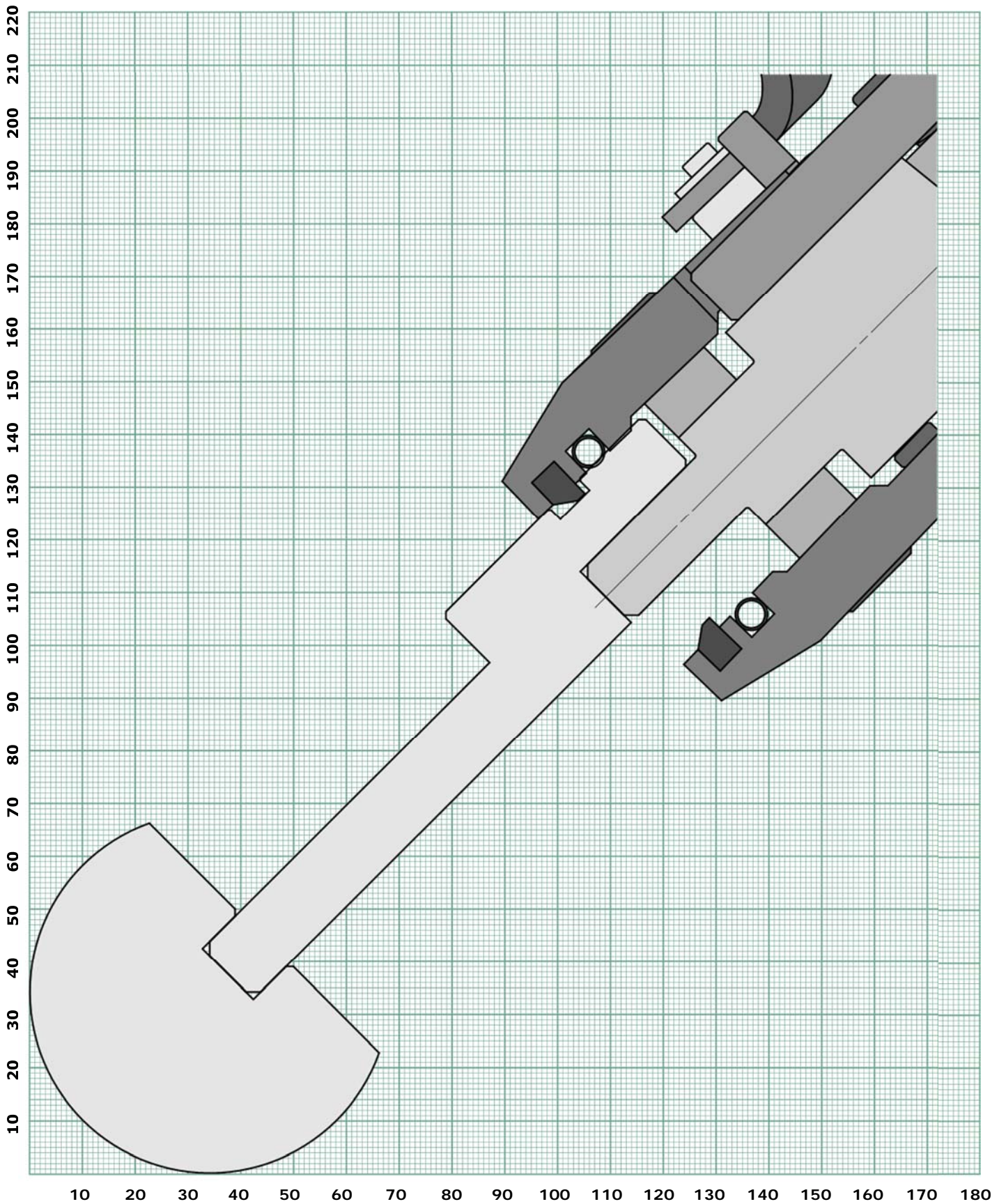

R40 Ruller with EH016 Holder

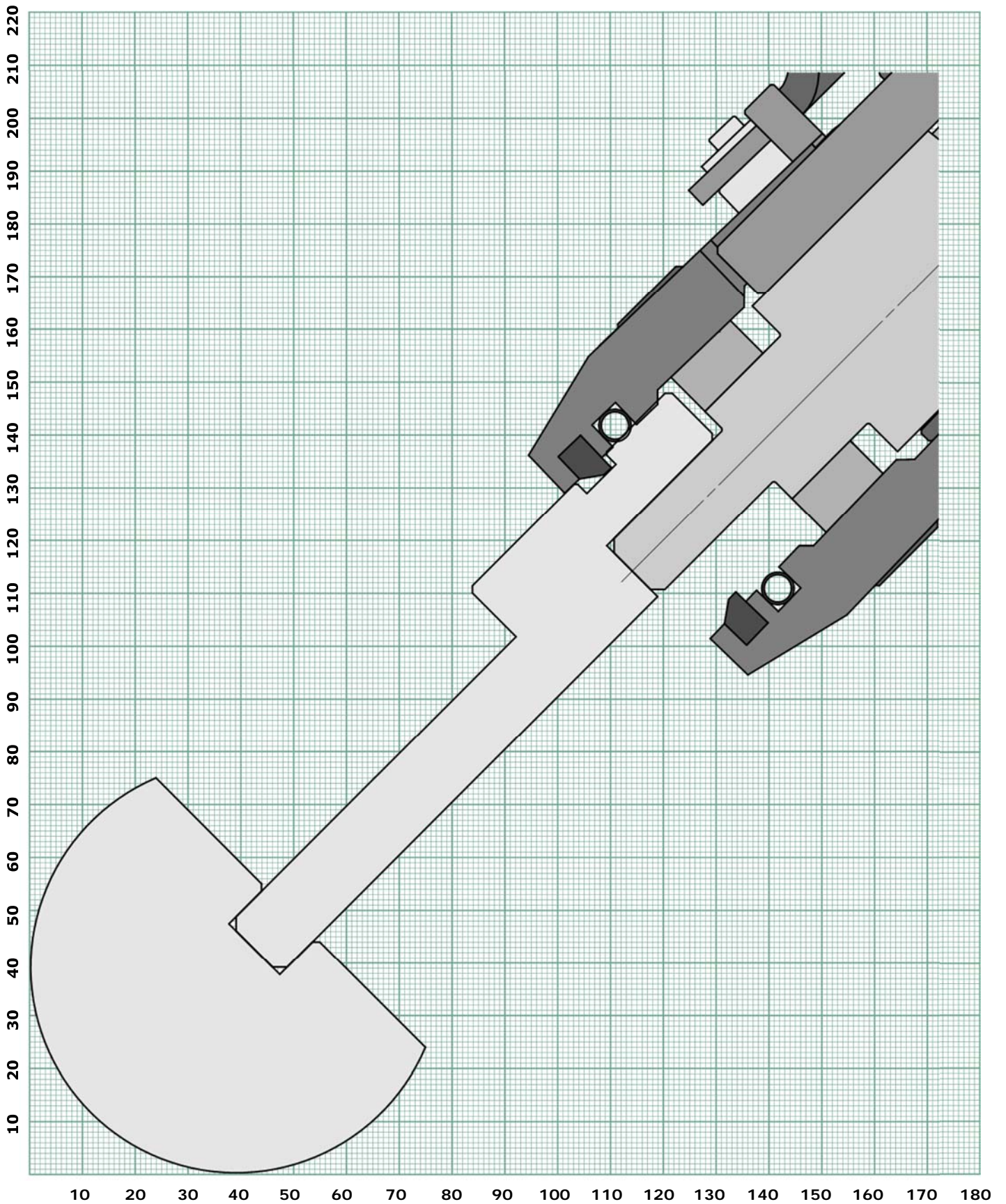

R45 Ruller with EH016 Holder

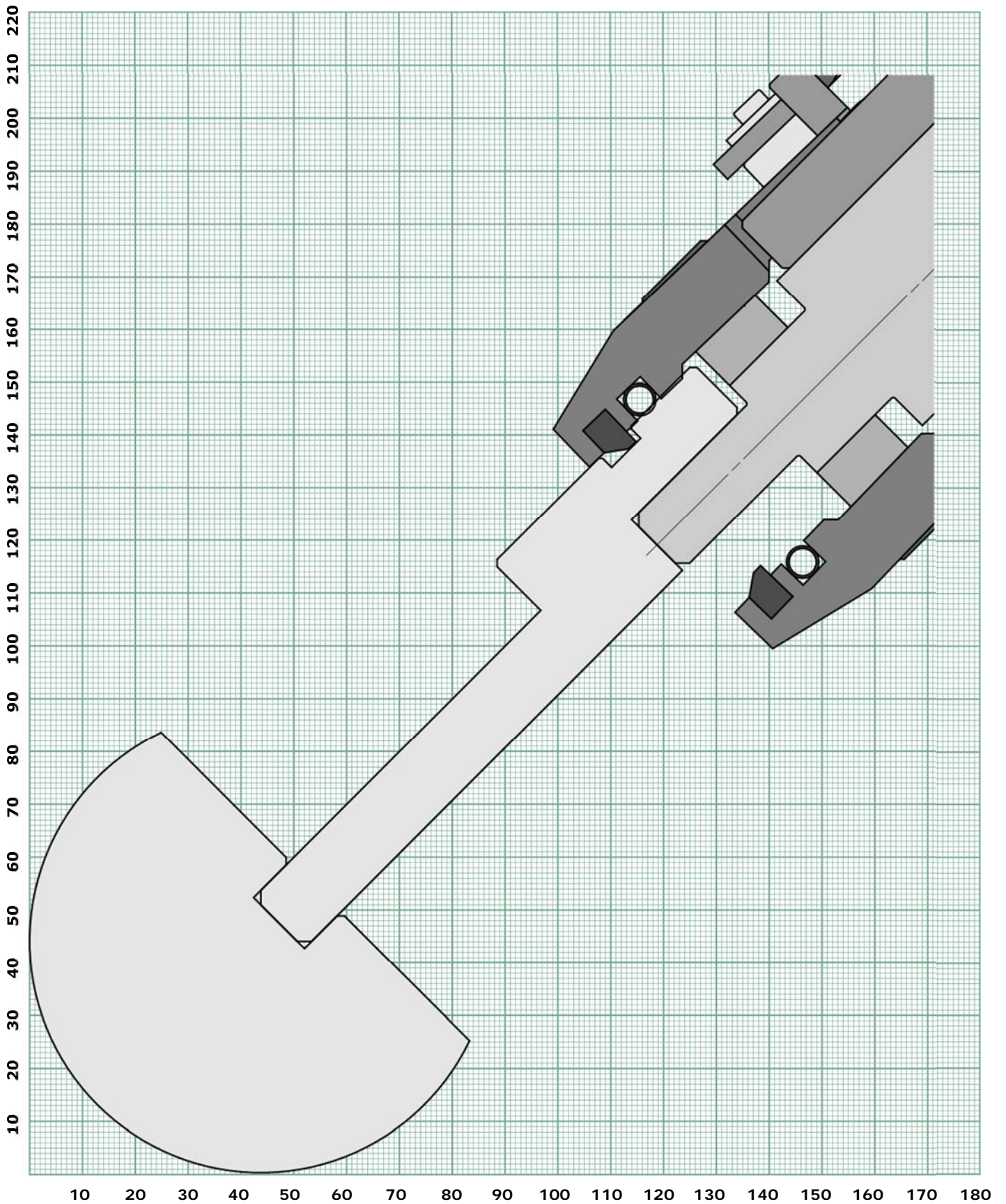

R50 Ruller with EH016 Holder

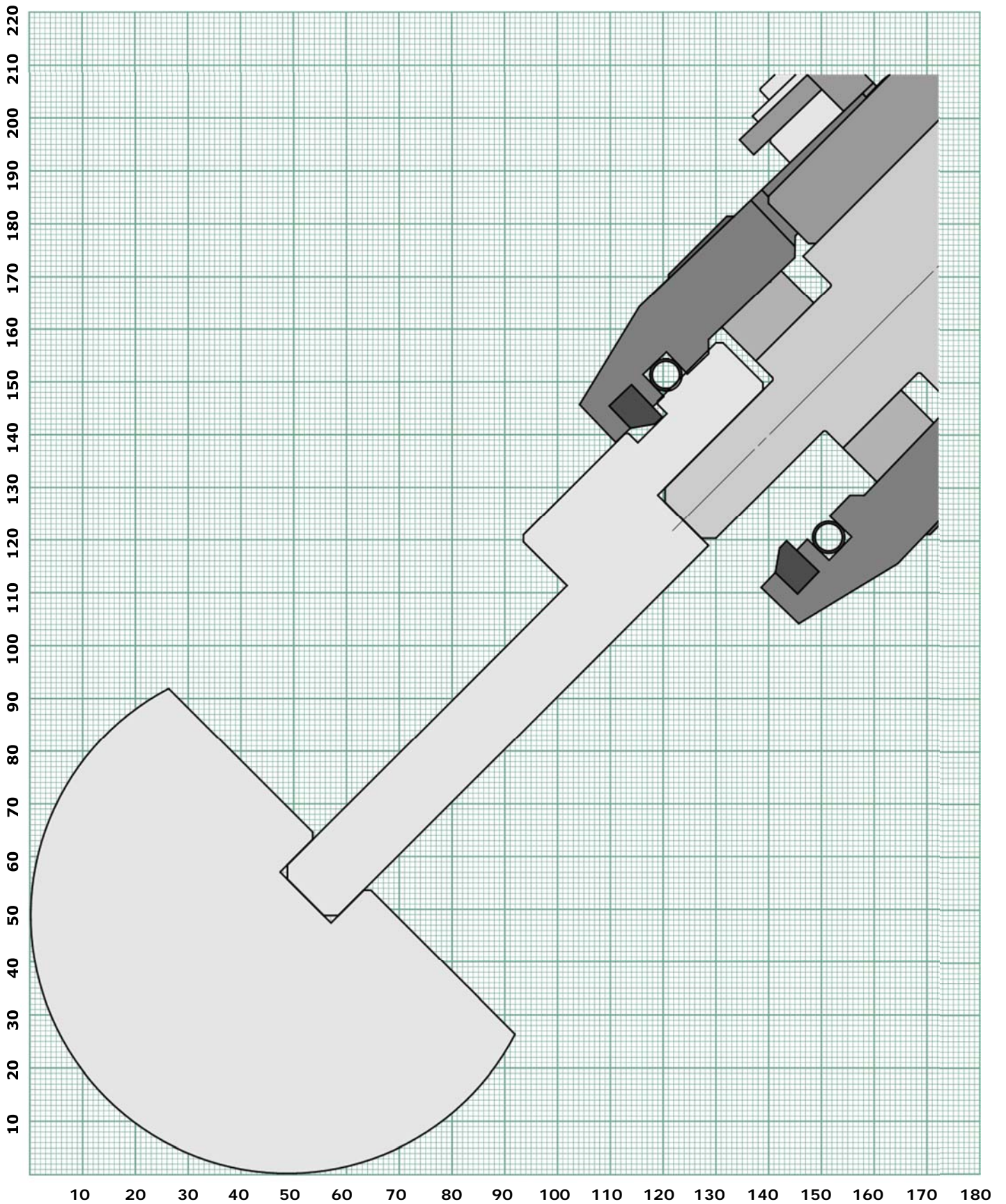

SEMISTANDARD PUNCH type 831 H200 30° R0,6

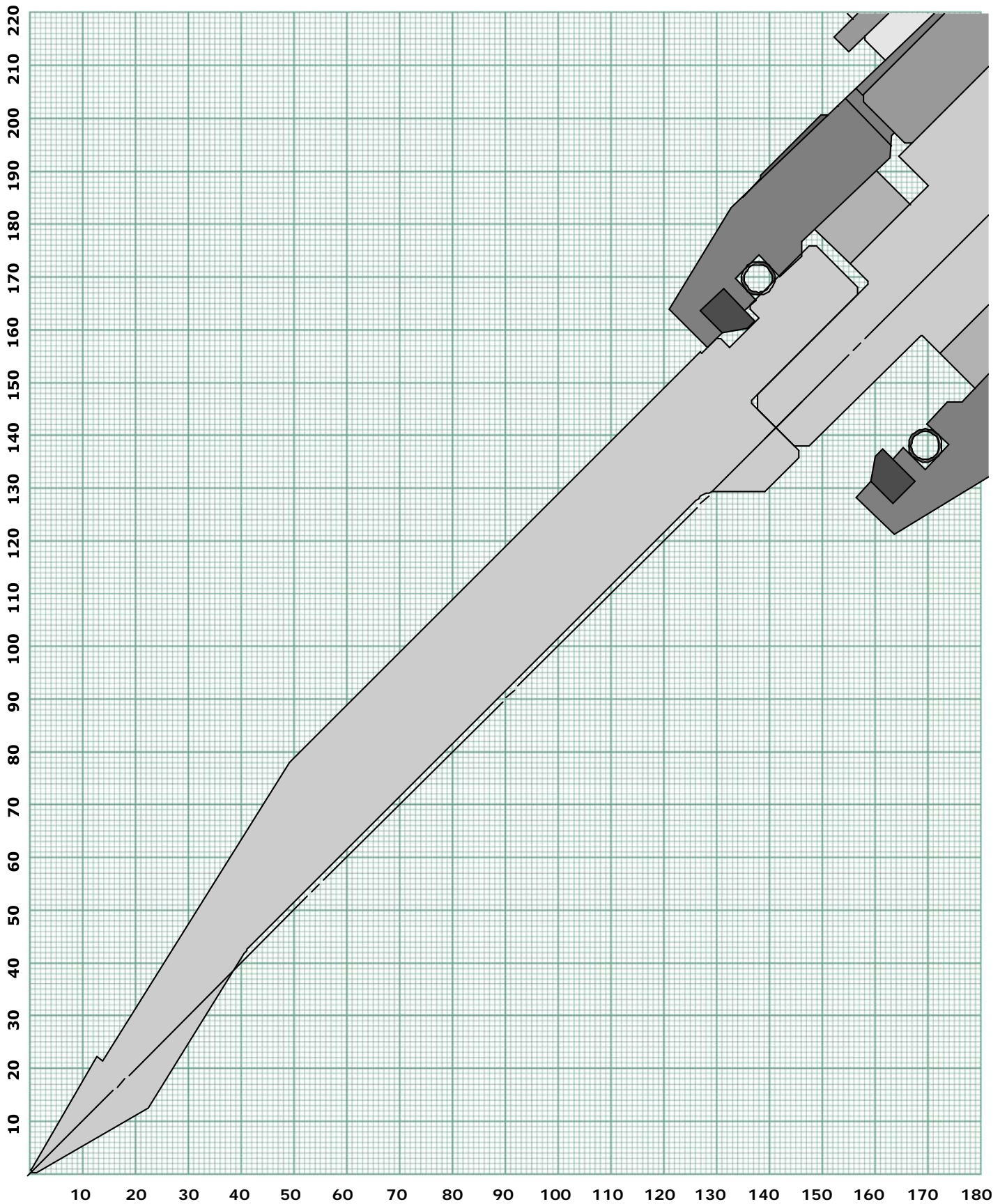

SEMISTANDARD PUNCH type 804 H220 86° R0,6

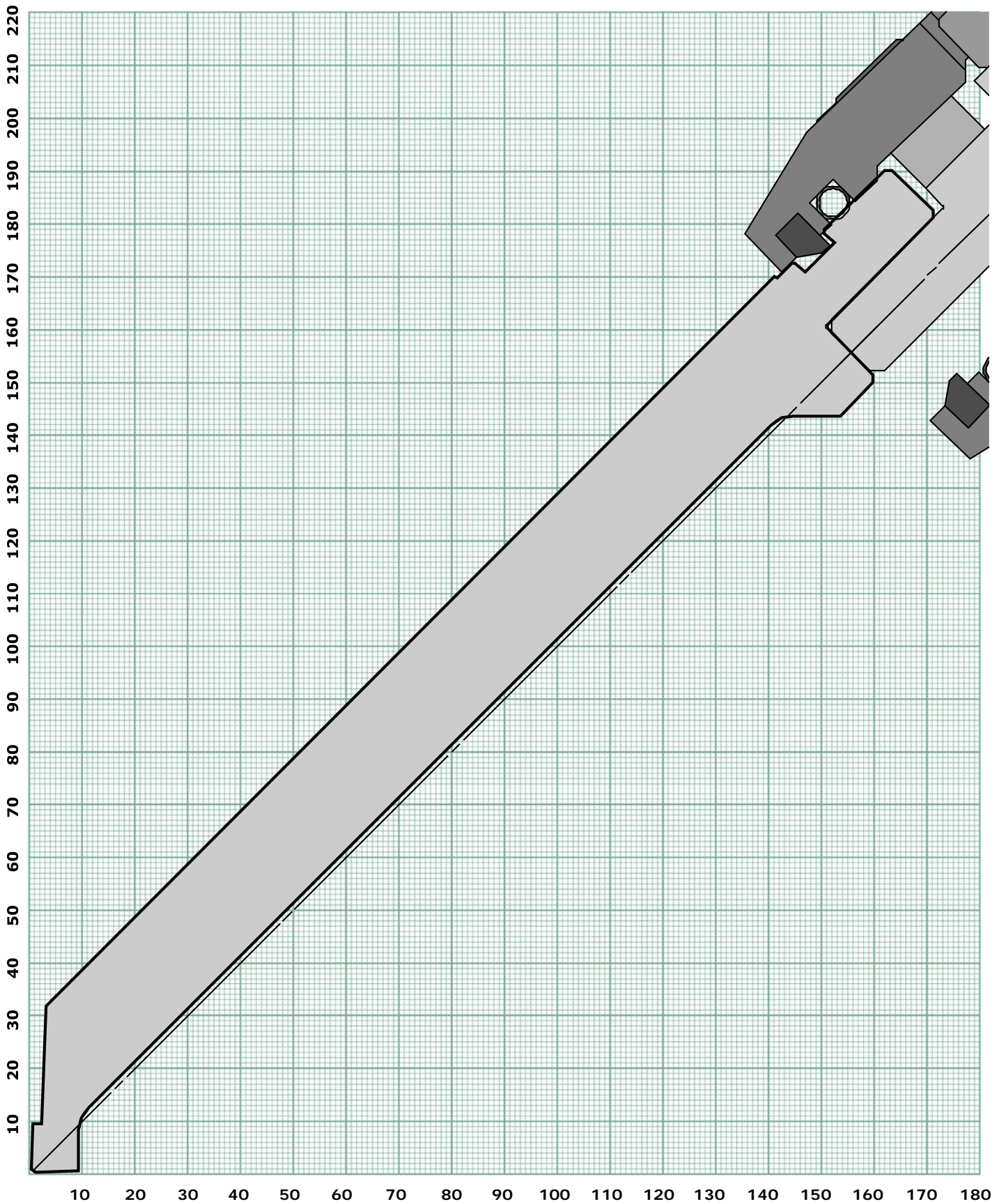

SEMISTANDARD PUNCH type 841 H200_W55 60° R0,6

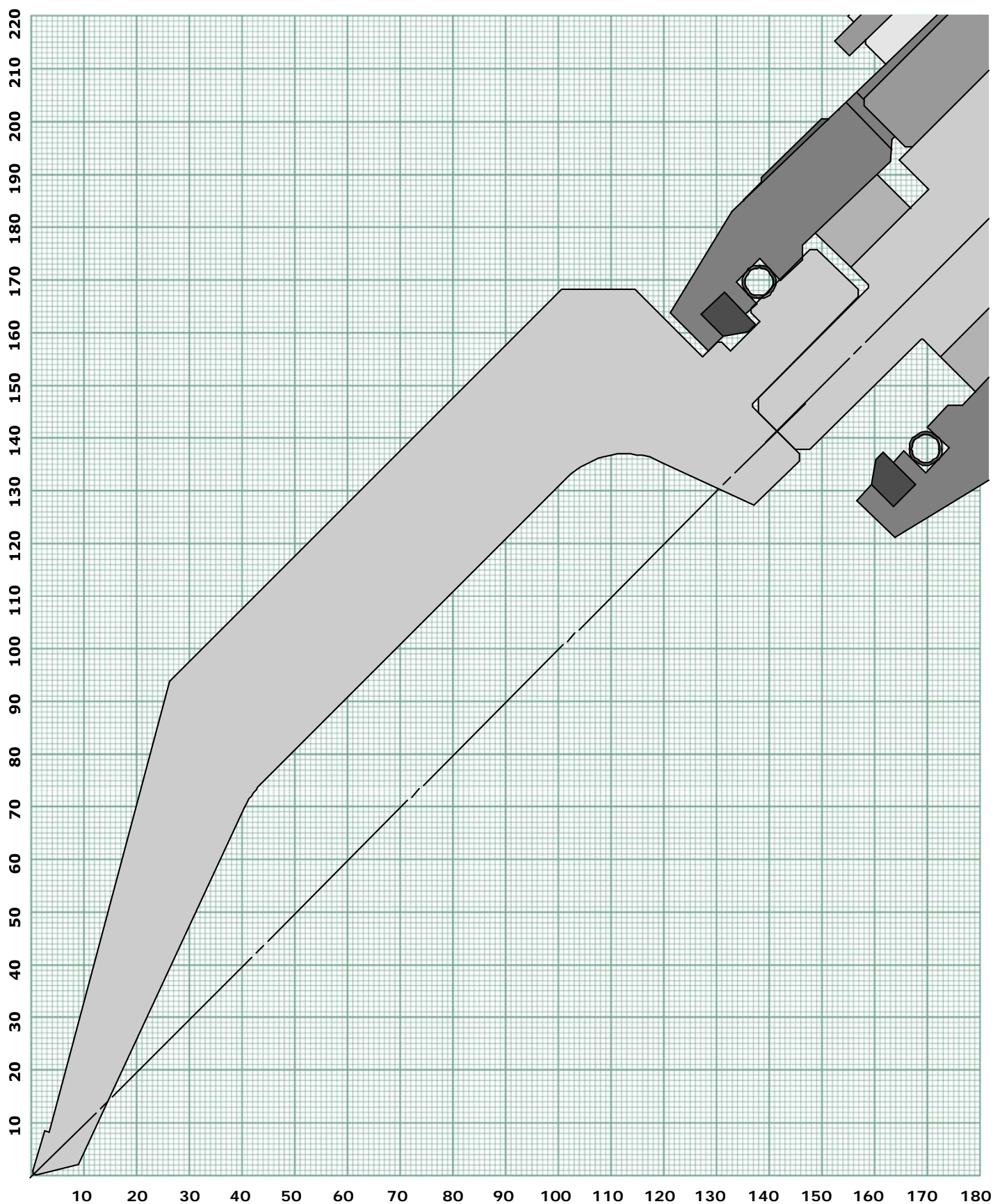

SEMISTANDARD PUNCH type 841 H200_W95 60° R0,6

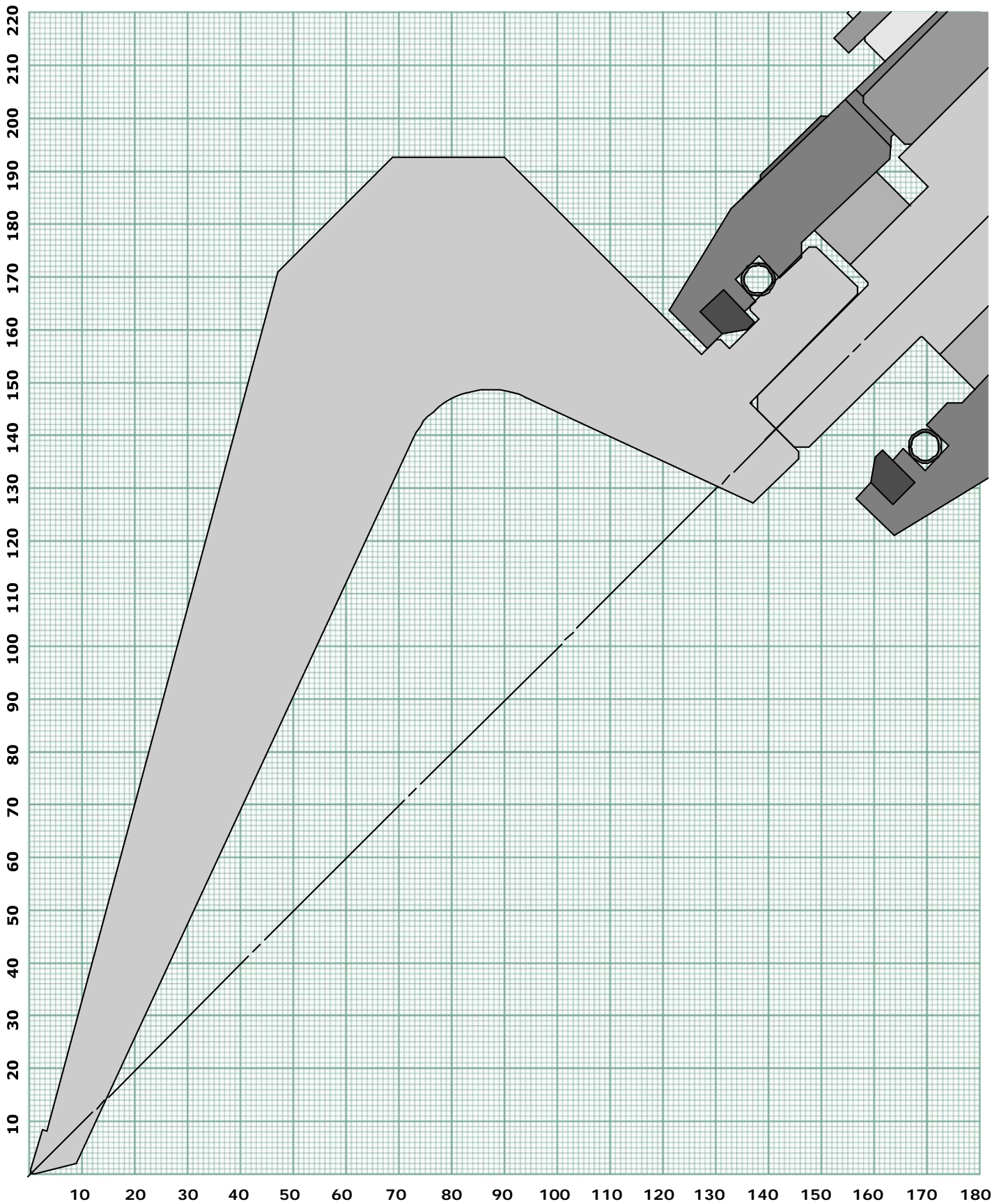

SEMISTANDARD PUNCH type 846 H200_W55 86° R0,6

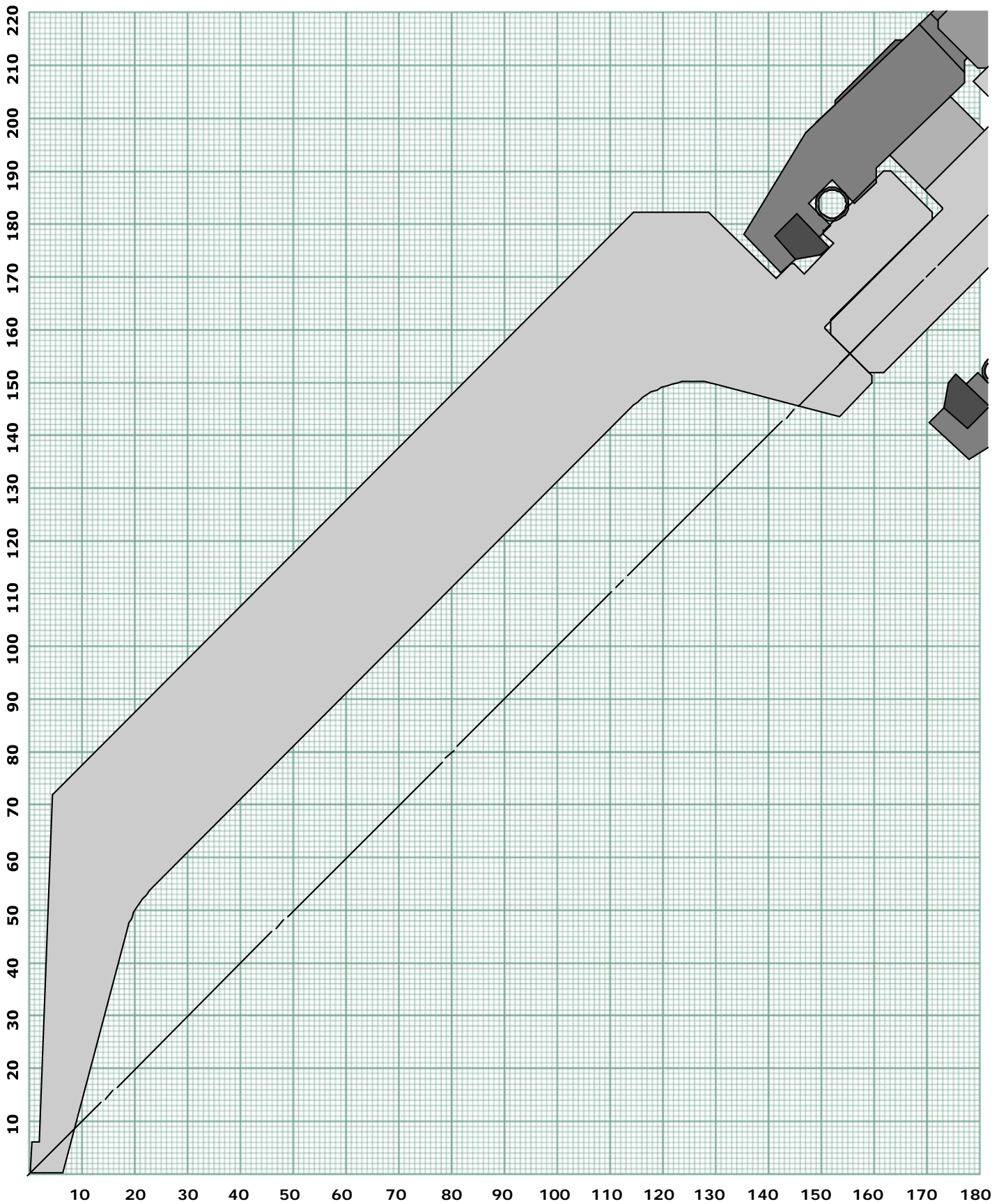

SEMISTANDARD PUNCH type 846 H220_W95 86° R0,6

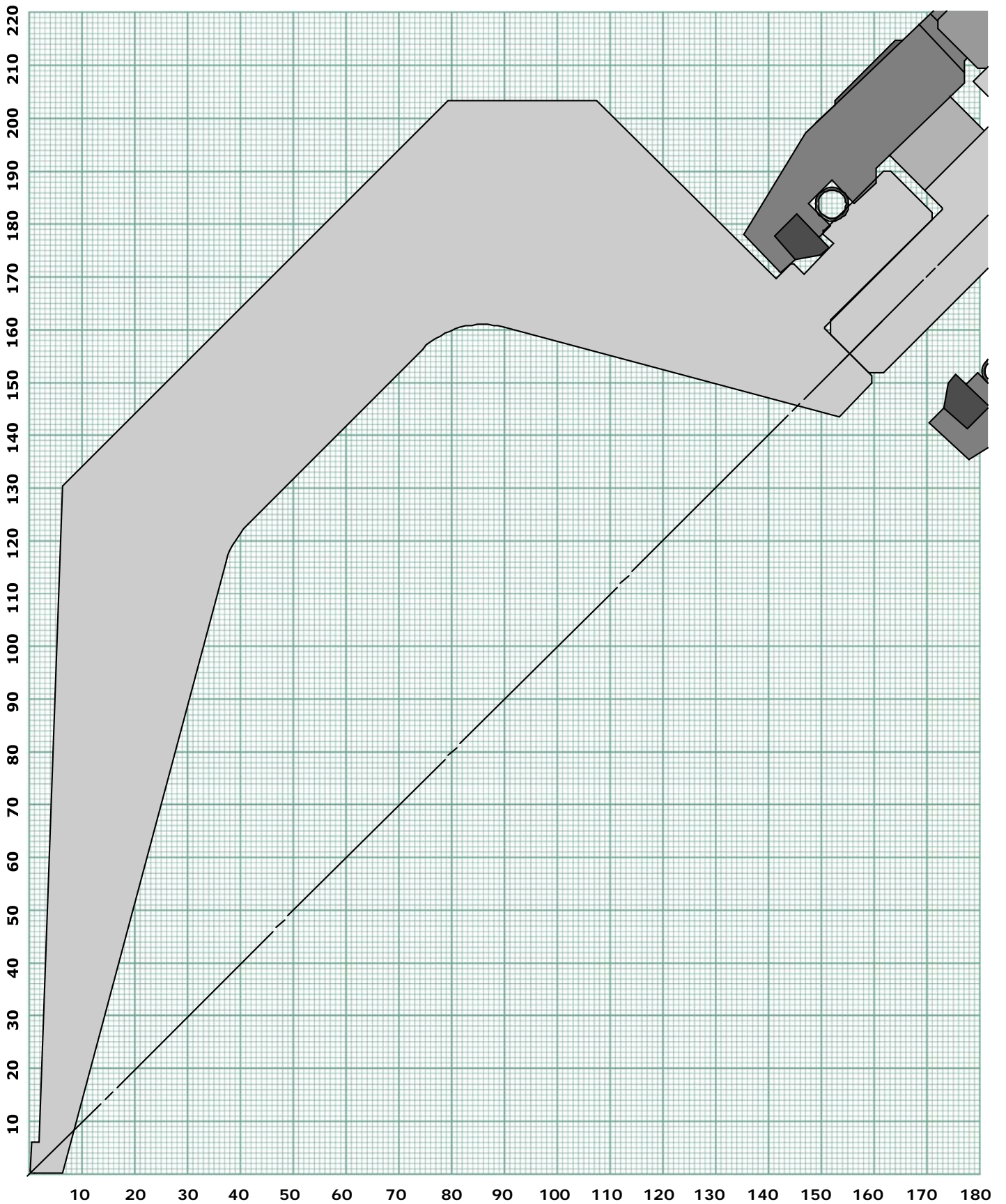

SEMISTANDARD PUNCH type 846 H200_W110 86° R0,6

